

# HOPPP

HO7124

HO7224

CE

Swing gate opener



**EN - Instructions and warnings for installation and use**

**IT - Istruzioni ed avvertenze per l'installazione e l'uso**

**FR - Instructions et avertissements pour l'installation et l'utilisation**

**ES - Instrucciones y advertencias para la instalación y el uso**

**DE - Installierungs-und Gebrauchsanleitungen und Hinweise**

**PL - Instrukcje i ostrzeżenia do instalacji i użytkowania**

**NL - Aanwijzingen en aanbevelingen voor installatie en gebruik**

**Nice**



# Contents

<b>1 - WARNINGS AND GENERAL PRECAUTIONS</b> .....	1
1.1 - Safety warnings.....	1
1.2 - Installation warnings.....	1
1.3 - Operation warnings.....	1
<b>2 - PRODUCT DESCRIPTION AND INTENDED USE</b> .....	1
<b>3 - INSTALLATION</b> .....	2
3.1 - Preliminary installation checks.....	2
3.2 - Application limits:.....	2
3.3 - Preliminary installation set-up work.....	2
3.4 - Installation of gearmotor mod. HO7124 - HO7224.....	2
3.5 - Mechanical limit switch adjustment.....	3
3.6 - Manually releasing and locking the gearmotor.....	3
<b>4 - ELECTRICAL CONNECTIONS</b> .....	3
4.1 - Gearmotor electrical connections.....	3
4.2 - Connection of other devices.....	3
4.3 - Routing connected devices.....	3
4.4 - Initial start-up and connection check.....	4
4.5 - Learning of the connected devices.....	4
4.6 - Learning the mechanical stop positions.....	4
4.7 - Gate leaf movement check.....	5
<b>5 - TESTING AND COMMISSIONING</b> .....	5
5.1 - Testing.....	5
5.2 - Commissioning.....	5
<b>6 - CONTROL PANEL PROGRAMMING</b> .....	6
6.1 - Level 1 programming (ON-OFF functions).....	6
6.2 - Level 2 programming (adjustable parameters).....	6
6.3 - Special functions.....	8
6.4 - Deleting the memory.....	8
<b>7 - TROUBLESHOOTING... (troubleshooting guide)</b> .....	9
<b>8 - FURTHER INFORMATION</b> .....	10
8.1 - Connecting a radio receiver.....	10
8.2 - Connecting and installing the buffer battery mod. PS124.....	10
8.3 - Connecting the Oview programmer.....	11
8.4 - Connecting the solar power system Solemyo.....	11
8.5 - Connecting the external release system Kio.....	11
<b>9 - PRODUCT MAINTENANCE</b> .....	11
<b>PRODUCT DISPOSAL</b> .....	11
<b>TECHNICAL SPECIFICATIONS OF PRODUCT</b> .....	12
<b>Product lifetime</b> .....	13
<b>CE DECLARATION OF CONFORMITY</b> .....	14
<b>APPENDIX</b> .....	I
Instructions and warnings for the user.....	II
Images.....	IX

## 1 WARNINGS AND GENERAL PRECAUTIONS

### 1.1 - Safety warnings

- **IMPORTANT!** – This manual contains important instructions and warnings regarding safety. Incorrect installation may cause serious injury. Before commencing work, all sections of the manual must be read carefully. If in any doubt, suspend installation and call the Nice Support Service for clarification.
- **IMPORTANT!** – This manual contains important instructions. Keep it for future maintenance work and disposal of the product.
- **IMPORTANT!** – Under the latest European legislation, automatic door and gate installations must be compliant with the standards specified in Directive 2006/42/EC (formerly 98/37/EC) (the Machinery Directive) and the standards EN 12445, EN 12453, EN 12635 and EN 13241-1 in particular, which enable conformity of the automated functionality to be declared. **In the light of the above, all work involving installation, connection, testing and maintenance of the product must be carried out exclusively by qualified and competent technicians!**

### 1.2 - Warnings for installation

- Before commencing the installation, check if the product is suitable for the desired type of use (see "Usage limitation" paragraph 3.2 and the "Product technical specifications"). If it is not suitable, DO NOT continue with the installation.
- The contents of this manual refer to a standard system as described in **fig. 3**.
- **All installation and maintenance work must be carried out with the automation system disconnected from the electricity supply.** If the power disconnection device cannot be seen from where the automation system is positioned, then before starting work a notice must be attached to the disconnection device bearing the words "CAUTION! MAINTENANCE IN PROGRESS".
- The Control unit must be connected to an electricity supply line equipped with protective earthing.
- Handle the product with care during installation, taking care to avoid crushing, denting or dropping it, or contact with liquids of any kind. Keep the product away from sources of heat and naked flames. Failure to observe the above can damage the product, and increase the risk of danger or malfunction. Should this occur, suspend installation work immediately and contact the Nice Support Service.
- Do not modify any part of the product. Prohibited modifications can only lead to malfunctions. The manufacturer declines all responsibility for damage resulting from unauthorized changes made to the product.
- If the gate or door being automated has a pedestrian gate, then the system must include a control device that will inhibit the operation of the motor when the pedestrian gate is open.
- The product's packaging material must be disposed of in full compliance with local regulations.

### 1.3 - Warnings for use

- The product is not intended for use by persons, including children, with limited physical, sensory or mental capacities, or who lack experience or knowledge, unless supervised or trained in the use of the product by a person responsible for their safety.
- Any children near the automation system must be kept under supervision to ensure that they do not play with it.
- Do not allow children to play with the fixed control devices. Keep remote control devices out of the reach of children.

## 2 PRODUCT DESCRIPTION AND INTENDED USE

The devices making up this product are intended for use in the automation of gates or doors with swing leaves for residential and industrial applications. **CAUTION!** – Any other use than as specified herein or in environmental conditions other than as stated in this manual is to be considered improper and is strictly prohibited!

The main part of the automation comprises one or two gearmotors (according to the number of leaves to be automated), each equipped with a DC motor and a straight tooth gear reducer. One of the gearmotors (mod. HO7124) is fitted with a control unit that manages operation. The control unit comprises a board with radio receiver, for receiving commands sent by the transmitter. It also has a provision for connection to various devices belonging to the Opera system, the Bluebus system and the Solemyo solar power system; see chapter 8 – Further information. It can house a buffer battery (mod. PS124, optional accessory) which in the event of a power failure guarantees a number of automation manoeuvres in the subsequent hours.

In the event of a power failure, the gate leaves can also be moved by unlocking the gearmotor by means of the special key; see paragraph 3.6.

Other accessories available include the receivers with "SM" connector (SMXI, OXI, etc.), see chapter 8 - Further information.

# 3 INSTALLATION

## 3.1 - Pre-installation checks

Before going ahead with the installation, check the integrity of the product components, and ensure the model chosen is suitable for its intended use and for the environment in which it is to be installed.

- Check that all the material to be used is in excellent condition and suitable for its intended use.
- Check that the ground-mounted mechanical stops (not supplied), are present both when opening and closing the automation system.
- Check that the mechanical structure of the gate is suitable for the installation of automation and compliant with locally applicable regulations (if necessary, refer to the label on the gate). This product cannot be used to automate a gate which is not already in good, safe working order, neither can it fix faults caused by incorrect installation or poor maintenance of the gate.
- Check that the operating conditions of the devices are compatible with the usage limitation declared (see paragraph 3.2).
- Move the gate leaves manually in both directions and ensure that the resistance to movement is constant at all points of travel (there should not be any points where more force or less is required).
- Bring the gate leaves manually into a position at random, then let go and check that they remain stationary.
- Check that the gearmotor fixing zone is compatible with its overall dimensions (fig. 1).
- Check that the place where the gearmotor is to be installed allows enough space for its arm to execute its full range of movement (fig. 2).
- Check that there is sufficient room around the gearmotor for it to be released manually when required.
- Ensure that the surfaces on which the various devices are to be installed are strong and capable of ensuring a firm hold.
- Ensure that each device is installed in a position which is protected and does not expose it to accidental impacts.
- Ensure that all the electrical cables to be used are the type listed in Table 1.

## 3.2 - Application limits

Before starting gearmotor installation, perform the following checks:

- ensure that the leaf to be motor-powered remains within the limits specified in Graph 1;
- **maximum** leaf width: **2,4 m** (with weight up to max. 160 kg);
- **maximum** leaf weight: **250 kg** (with width up to max. 1,5 m);
- check limits specified in the table of "Product technical specifications";
- **minimum** width of space for gearmotor installation: **170 mm**;
- The arm fixing bracket must be located in a resistant area of the leaf (for example the frame), to guarantee a solid and safe fixture.

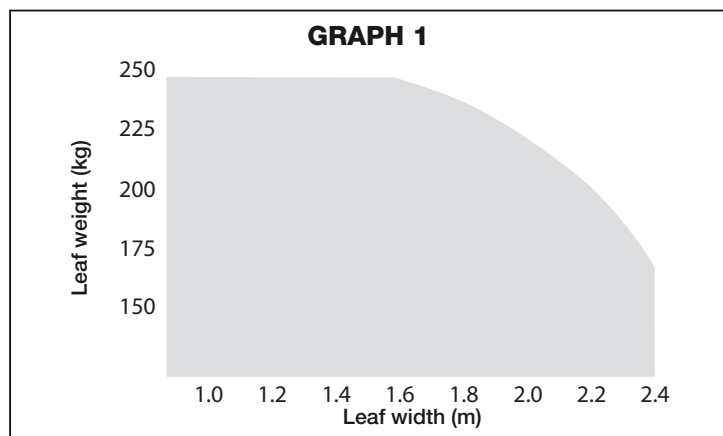

## 3.3 - Preliminary installation set-up work

Fig. 3 provides an example of an automation system, produced using Nice components (some components may not be present in the kit):

- a - Gearmotor with control unit model HO7124
- b - Gearmotor without control unit model HO7224
- c - Flashing light MLBT
- d - Pair of photocells model MOFB
- e - Digital keypad (mod. MOTB) - Transponder badge reader (mod. MOMB) - Key-operated selector switch (mod. MOSE)
- f - Pair of posts for photocells
- g - Mechanical stop on closing
- h - Electric lock

These parts are positioned according to a typical standard layout. With reference to fig. 3, locate the approximate position for installation of each component envisaged in the system. **Important** – Before installation, prepare the electric cables required for the system, with reference to fig. 4 and "Table 1 - Technical specifications of electric cables".

**Caution** – When laying the ducting for routing the electrical cables, also take into account that due to possible deposits of water in the routing ducts, the connection pipelines must not create condensate in the control unit, with consequent damage to the electronic circuits.

## 3.4 - Installation of gearmotor mod. HO7124 - HO7224

### WARNINGS

- **Incorrect installation may cause serious physical injury to those working on or using the system.**
- **Before starting automation assembly, make the preliminary checks as described in paragraphs 3.1 and 3.2.**

01. Measure position "B" (fig. 5);
02. Move the leaf to the maximum required opening position and check that the angle found remains within the values shown on Graph 2;
03. On Graph 2, with value "B" and the opening angle, calculate value "A" (fig. 6). Example: if "B" is 100 mm and the required angle is 100°, value "A" is approx. 180 mm.

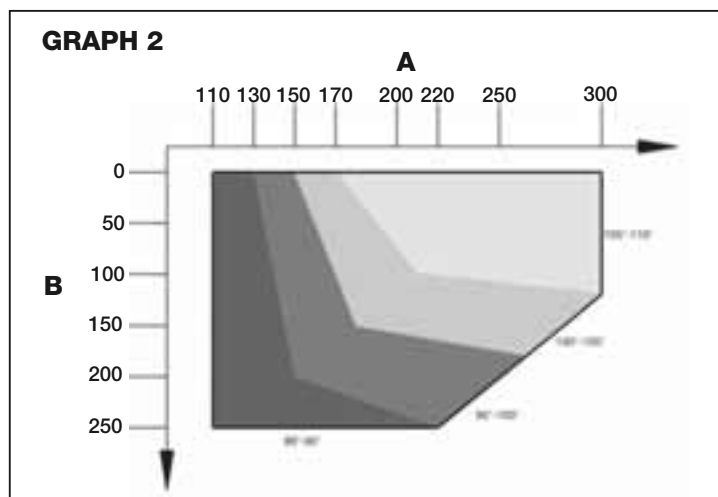

04. Mount the gearmotor **fixing bracket** on the wall in a horizontal position, as shown in fig. 7: use suitable plugs, screws and washers (not supplied);
05. Fix the gearmotor to the previously mounted bracket, as shown in fig. 7-3: use the screw supplied (M4.8x13);
06. Then fix the **curved arm** to the straight arm, using the pin and Benzring snap ring (fig. 7-4); fix the leaf fixing bracket to the curved arm, using the pin and Benzring snap ring (fig. 7-4);
07. Manually release the gearmotor (fig. 7-6), see paragraph 3.6;
08. At this point, determine the zone for fixing the bracket on the gate leaf, setting the gearmotor arms to the maximum extension (fig. 7-7): **it is important to position the bracket at the point furthest from the position of the gearmotor;**

TABLE 1 – Technical specifications of electric cables (fig. 4)

Connection	Cable type	Maximum admissible length
<b>A:</b> CONTROL UNIT POWER SUPPLY cable	1 Cable 3 x 1,5 mm <sup>2</sup>	30 m (note 1)
<b>B:</b> ELECTRIC LOCK Cable	1 Cable 2 x 1 mm <sup>2</sup>	6 m
<b>C:</b> BLUEBUS DEVICE cable	1 Cable 2 x 0,5 mm <sup>2</sup>	20 m (note 2)
<b>D:</b> KEY-OPERATED SELECTOR SWITCH cable	2 cables 2 x 0,5 mm <sup>2</sup> (note 3)	50 m
<b>E:</b> GEARMOTOR POWER SUPPLY Cable	1 Cable 3 x 1,5 mm <sup>2</sup>	10 m
<b>F:</b> FLASHING LIGHT with aerial cable	1 Cable 2 x 1 mm <sup>2</sup>	20 m
	1 RG58 type shielded cable	20 m (less than 5 m recommended)

**Note 1** – If the power cable exceeds a length of 30 m, use a cable with a larger section (3x2.5 mm<sup>2</sup>); in this case earthing is required in the vicinity of the automation.

**Note 2** – If the Bluebus cable exceeds a length of 20 m, up to a maximum of 40 m, use a cable with a larger section (2 x 1 mm<sup>2</sup>).

**Note 3** – These 2 cables may be replaced with a single cable of 4 x 0,5 mm<sup>2</sup>.

**CAUTION!** – The cables used must be suited to the type of environment of the installation site.

- 09. Drill the leaf and fix the bracket using suitable screws (not supplied) (figs. 7-8, 7-9 and 7-10);
- 10. Before locking the gearmotor, adjust the mechanical opening limiter as required (paragraph 3.5).

### 3.5 - Adjusting the mechanical opening limiter

- 01. Manually move the gate leaves to the maximum opening position;
- 02. Rotate the plastic disk on the lower section of the gearmotor, to position the aperture under the arm as shown in fig. 8;
- 03. Insert the limiter in the first possible place: try to insert as shown in fig. 8 (opening direction);
- 04. Rotate the disk to prevent the limiter from dropping, moving the aperture to the position shown in fig. 8; for more precise adjustments, use the adjustment screw (fig. 8);
- 05. If there is no floor-mounted stop in the system, this procedure must be repeated from point 01 also for the closing limiter;
- 06. Lastly, tighten the disk fixing nut fully down (fig. 8) to ensure that it does not rotate accidentally.

### 3.6 - Manually releasing and locking the gearmotor

The gearmotor is equipped with a mechanical locking system to enable manual opening and closing of the gate. These manual operations should only be performed in the event of a power failure, malfunctions or during the installation procedures.

#### Releasing (fig. 9):

- 01. Insert the key;
- 02. Turn the key anti-clockwise (180°);
- 03. At this point the leaf can be moved manually to the required position.

#### Locking (fig. 10):

- 01. Turn the key clockwise through 180°;
- 02. Remove the key.

## 4 ELECTRICAL CONNECTIONS

The electrical connection of the various devices (photocells, digital keyboard, transponder card readers, etc.) contained in the automation with the control unit must be made by means of the Nice "Bluebus" system.

### Description of electrical connections (fig. 11)

<b>AERIAL</b>	input for the radio receiver aerial
<b>FLASH</b>	output for 1 flashing light with 12V (maximum 21W) bulb. [*]
<b>ELS</b>	output for 12Vac (maximum 15VA) electric lock. [*]
<b>BLUEBUS</b>	input for compatible devices (MOFB, MOFOB, MOB and MOTB); they are connected in parallel using two conductors through which both the electricity supply and the communication signals travel; no polarity needs to be observed. The electrical connection to be used is of the parallel type and no polarity needs to be observed. During the learning stage, the control unit will recognise individually all devices connected to it thanks to a unique code. Each time a device is added or eliminated, it will be necessary to make the control unit perform the learning operation (see paragraph 4.5).
<b>STOP</b>	input for devices that cause the immediate interruption of the manoeuvre in progress (with a short reverse run); NO and NC contacts, as well as devices with 8.2 kΩ constant resistance output (sensitive edges) can be connected to this input. Each device connected to this input is recognised individually by the control unit during the learning stage (paragraph 3.4); in this stage, if the control unit detects any variations with respect to the learned state, it causes a STOP. One or more devices of the same or different kinds can be connected to this input: <ul style="list-style-type: none"> <li>- connect a number of NO devices in parallel without quantity limits;</li> <li>- several NC devices can be connected in series, with no limits as to quantity;</li> <li>- connect 2 devices with 8.2 kΩ constant resistance output in parallel. If there are more than 2 devices, they must be connected in a cascade with just one 8.2 kΩ termination resistance;</li> <li>- connect 2 NO and NC devices in parallel, placing a 8.2 kΩ resistance in series on the NC contact (this also allows for a combination of three devices NO - NC and 8.2 kΩ)</li> </ul>
<b>P.P.</b>	input for devices which control Step-by-Step manoeuvres. NO contacts can be connected to this input
<b>OPEN</b>	input for control devices, which intervene to cause partial opening 1 manoeuvre; possibility of connecting NO type contacts
<b>M</b>	output for gearmotor without control unit (HO7224)

[\*] The outputs FLASH and ELS can be programmed with other functions (see "TABLE 5 – Level 1 functions"; or via the Oview programmer; see paragraph 8.3).

### 4.1 - Gearmotor electrical connections

**Caution!** – Only make the electrical connections after installing the gearmotor.

#### WARNINGS!

- Connections must be made exclusively by qualified personnel.
- All electrical connections must be made with the unit disconnected from the mains power supply and with the buffer battery disconnected (if present).

- The electrical power line must be fitted with a device that enables complete disconnection of the automation from the mains. The disconnection device must have a gap between contacts that ensures complete disconnection in the conditions of overvoltage category III, in compliance with installation regulations.

- 01. Open the cover of the gearmotor (fig. 12-1);
- 02. Route the power cable and other electric cables through the hole on the lower section of the gearmotor (afb. 12-2);
- 03. First connect the power cable of the motor with the control unit HO7124: loosen the cable clamp (fig. 12-3) and connect the power cable as shown in fig. 12-4; then secure the cable by means of the cable clamp (fig. 12-5);
- 04. Then connect the cable powering the motor without control unit (HO7224) as shown in fig. 13;
- 05. Lastly connect the electric cables of the various devices present, with reference to fig. 11 and paragraph 4.3. *Note – To facilitate cable connections, the terminals can be removed from their seats;*
- 06. In the Table 2 identify the type corresponding to the system to be programmed and if necessary, on the control unit, set the selector JA and jumper JB as described;
- 07. Close the gearmotor cover (fig. 12-6).

	JA	JB
	JA	JB
	JA	JB
	JA	JB
	JA	JB
	JA	JB
	JA	JB
	JA	JB

### 4.2 - Connection of other devices

If further devices present in the system need to be powered, for example a transponder card reader or the key selector light, these devices can be connected to the control unit using terminals "P.P. (positive)" and "STOP (negative)" (fig. 11). The power supply voltage is 24 Vdc, -30% ÷ +50%, with maximum available current 200 mA.

**Note** – The voltage present on terminals "P.P." and "STOP" remains connected even when the "Stand By" function is activated on the card.

### 4.3 -Routing connected devices

To enable control unit recognition of the devices connected to the BlueBus system, they need to be routed. This operation must be performed by positioning

the electric jumper correctly on each device; see the relative instruction manual of individual devices: see **fig. A** and **Table 3**.

To route other devices, consult the relative instruction manuals. At the end of the installation procedure, or after removing photocells or other devices, the device learning procedure must be performed as described in paragraph 4.5.

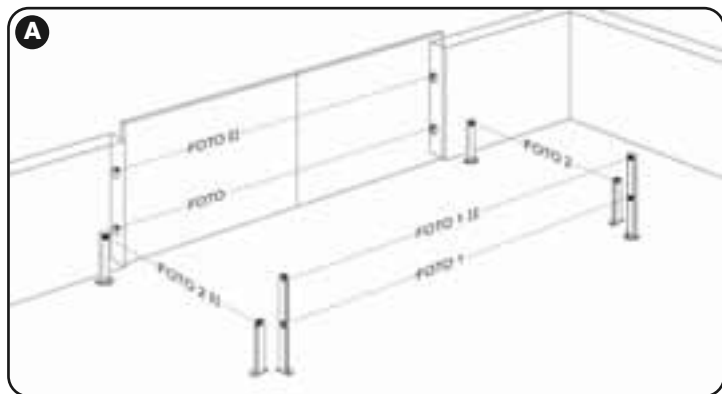

**TABLE 3 - PHOTOCELL ADDRESSES**

Photocell	Jumpers
<b>FOTO</b> External photocell h = 50 with trip on closure (stops and inverts movement)	
<b>FOTO II</b> External photocell h = 100 with trip on closure (stops and inverts movement)	
<b>FOTO 1</b> Internal photocell h = 50 with trip on closure (stops and inverts movement) and opening (stops and restarts when photocell is disengaged)	
<b>FOTO 1 II</b> Internal photocell h = 100 with trip on closure (stops and inverts movement) and opening (stops and restarts when photocell is disengaged)	
<b>FOTO 2</b> Internal photocell with trip on opening (stops and inverts movement)	
<b>FOTO 2 II</b> Internal photocell with trip on opening (stops and inverts movement)	
<b>FOTO 3</b> <b>CONFIGURATION NOT ADMITTED</b>	

#### 4.4 - Initial start-up and electrical connections

After powering up the control unit, perform the following checks:

- After a few seconds, make sure that the "Bluebus" LED (**fig. 15**) flashes regularly with a frequency of about one flash per second.
- Make sure that the LEDs on the photocells (**fig. 15**) flash (both on TX and RX). The type of flashing is not important during this stage.
- Make sure that the flashing light connected to the FLASH output is off.

If the above conditions are not satisfied, switch off the power supply to the control unit and check the electrical connections previously made.

#### 4.5 - Learning of the devices connected

After the initial power-up, the control unit must be able to recognise the devices connected to the "Bluebus" and "Stop" inputs.

**IMPORTANT !** – The learning procedure must be performed even if no device is connected to the control unit.

The control unit is able to recognise the various connected devices individually through the self-learning procedure and detect possible faults. For this reason it is necessary to perform self-learning every time a new device is added or an existing device is removed.

To indicate when the self-learning procedure is required, LEDs **L1** and **L2** on the control unit (**fig. 15**) emit a number of slow flashes:

- 01.** Press and hold down ◀ and "Set" keys at the same time (**fig. 15**).
- 02.** Release the keys when LEDs **L1** and **L2** start flashing quickly (after approx. 3 seconds).
- 03.** Wait a few seconds for the control unit to complete the device learning phase.
- 04.** At the end of this phase, the "Stop" LED must be lit and LEDs "L1" and "L2" must be turned off (LEDs **L3** and **L4** may start flashing).

#### 4.6 - Learning the mechanical stop positions

After learning the connected devices (paragraph 4.6), the positions of the mechanical stops must also be learnt (maximum opening and maximum closing).

There are three ways to perform this procedure: **automatic**, **manual** or **combined**.

In **automatic mode**, the control unit learns the positions of the mechanical stops and calculates the most suitable offset value for the leafs (SA and SC, **fig. B**).

In **manual mode**, the six positions of the mechanical stops **fig. B** are programmed one by one, moving the leafs to the required points. The position to program is identifiable by the flashing status of one of the 6 leds (L1-L6), see **Table 4**.

In **combined mode**, the automatic procedure can be performed and then, using the manual procedure, one or more positions may be modified, with the exception of positions "0" and "1" (**fig. B**) which coincide with the positions of the mechanical stops.

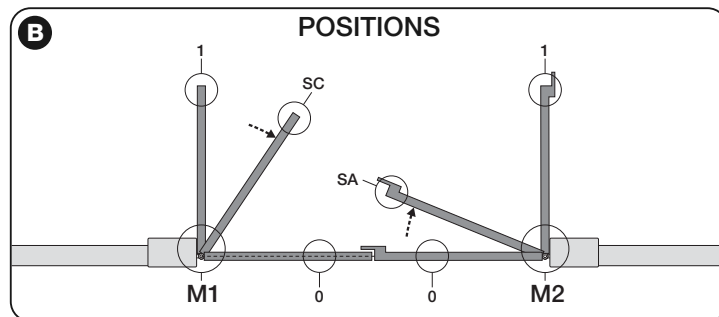

**TABLE 4**

Position	Led	Description
<b>Position 0 (motor 1)</b>	<b>L1</b>	Maximum closing position: when leaf 1 reaches closing mechanical stop
<b>Position 0 (motor 2)</b>	<b>L2</b>	Maximum closing position: when leaf 2 reaches closing mechanical stop
<b>Position SA (motor 2)</b>	<b>L3</b>	Opening offset: when leaf 2 passes this position the opening of leaf 1 begins
<b>Position SC (motor 1)</b>	<b>L4</b>	Closing offset: when leaf 1 reaches this position, leaf 2 begins to close
<b>Position 1 (motor 1)</b>	<b>L5</b>	Maximum opening position: when leaf 1 reaches the opening mechanical stop
<b>Position 1 (motor 2)</b>	<b>L6</b>	Maximum opening position: when leaf 2 reaches the opening mechanical stop

##### 4.6.1 - Learning in automatic mode

- 01.** Press and hold keys "Set" and "▶" at the same time;
- 02.** Release the keys when leds "L3" and "L4" start flashing quickly (after approx. 3 seconds);
- 03.** Ensure that the automation completes the following sequences of manoeuvres:
  - a - Low speed closure of gearmotor M1 through to the mechanical stop
  - b - Low speed closure of gearmotor M2 through to the mechanical stop
  - c - low speed opening of gearmotor M2 and gearmotor M1 through to the mechanical stop
  - d - High speed closure of gearmotors M1 and M2

##### Warnings:

- If the first manoeuvre performed by one or both the leafs is not closing, press "◀" or "▶" to stop the learning phase; then check the position of selector **JA** and jumper **JB** (see **Table 2**) or check connection polarity of the motor without control unit (HO7224).
- If the first closing manoeuvre is not controlled by M1, press "◀" or "▶" to stop the learning phase; then check the position of selector **JA** and jumper **JB**, see **Table 2**;

- 04.** At the end of the Closing manoeuvre of the 2 motors (d), leds "L3" and "L4" turn off to indicate that the procedure has been completed correctly.

##### Warnings:

- During the automatic learning procedure, if a photocell trips or a device connected to the "stop" input is activated, the procedure is interrupted and led **L1** starts flashing. To resume the learning process, the procedure must be started again from point **01**;
- The automatic learning procedure can be repeated at any time, also after installation; for example following modifications to the position of the mechanical stops.

##### 4.6.2 - Learning in manual mode

**Caution!** – From step 03 onwards:

- to move from led **L1** to **L6**, briefly press key ◀ or ▶ (the led flashes to indicate the current position);
- to move the motor in one or the other direction, press and hold key ◀ or ▶.

- 01.** Press and hold keys "Set" and "▶" at the same time.
- 02.** Release the keys when led "L1" starts flashing (after approx. 1 second);  
**Note** – After 3 seconds have elapsed, if the keys "Set" and "▶" are not released, the "automatic learning" procedure is started up, and not the manual procedure.

**03. • LED L1 flashes: position 0 of M1**

To bring motor 1 to **position 0 (fig. B)**: press and hold down the ◀ or ▶ keys. On reaching the position, release the key to stop the manoeuvre. To memorise the position, press and hold down the “Set” key for at least 3 seconds and then release it (after 2 seconds LED L1 remains on and on releasing the “Set” key LED L2 begins flashing).

**• LED L2 flashes: position 0 of M2**

To bring motor 2 to **position 0 (fig. B)**: press and hold down the ◀ or ▶ keys. On reaching the position, release the key to stop the manoeuvre. To memorise the position, press and hold down the “Set” key for at least 3 seconds and then release it (after 2 seconds LED L2 remains on and on releasing the “Set” key LED L3 begins flashing).

**• LED L3 flashes: position SA of M2**

To bring motor 2 to **position SA (fig. B)**: press and hold down the ◀ or ▶ keys. On reaching the position, release the key to stop the manoeuvre. To memorise the position, press and hold down the “Set” key for at least 3 seconds and then release it (after 2 seconds LED L3 remains on and on releasing the “Set” key LED L4 begins flashing).

**• LED L4 flashes: position SC of M1**

To bring motor 1 to **position SA (fig. B)**: press and hold down the ◀ or ▶ keys. On reaching the position, release the key to stop the manoeuvre. To memorise the position, press and hold down the “Set” key for at least 3 seconds and then release it (after 2 seconds LED L4 remains on and on releasing the “Set” key LED L5 begins flashing).

**• LED L5 flashes: position 1 of M1**

To bring motor 1 to **position 1 (fig. B)**: press and hold down the ◀ or ▶ keys. On reaching the position, release the key to stop the manoeuvre. To memorise the position, press and hold down the “Set” key for at least 3 seconds and then release it (after 2 seconds LED L5 remains on and on releasing the “Set” key LED L6 begins flashing).

**• LED L6 flashes: position 1 of M2**

To bring motor 2 to **position 1 (fig. B)**: press and hold down the ◀ or ▶ keys. On reaching the position, release the key to stop the manoeuvre. To memorise the position, press and hold down the “Set” key for at least 3 seconds and then release it to exit programming (after 2 seconds LED L6 remains on until the “Set” key is released).

**Note – Manual programming of a system with a single gearmotor:** proceed as described at the start of this paragraph from step 01. **At step 03** proceed as follows:

- **program the positions of leds L1 (0 of M1) and L5 (1 of M1) as follows:** press and hold “Set” for at least 3 seconds and then release (after 2 sec. the led remains lit and on release of the “Set” key the next led starts to flash).
- **do not program the positions of leds L3 (SA of M2) - L4 (SC of M1):** to move between positions, briefly press “◀” or “▶”.

**4.6.3 - Learning in combined mode**

Perform this procedure after completing the automatic learning cycle:

- 01.** Press and hold keys “Set” and “▶” at the same time.
- 02.** Release the keys when led “L1” starts flashing (after approx. 1 second);  
*Note – After 3 seconds have elapsed, if the keys “Set” and “▶” are not released, the “automatic learning” procedure is started up, and not the manual procedure.*
- 03.** Briefly press key “◀” or “▶” to move the flashing led (L1-L6) to the position to be programmed and proceed for each position, as described in step 03 of the manual learning procedure (paragraph 4.7.2).  
Repeat this operation for all other positions to be modified.

To complete the manual learning process, press key “▶” repeatedly to move the led that flashing beyond position L6.

**4.7 - Checking movement of gate leaves**

At the end of the learning procedure, it is advisable to make the control unit perform a few opening and closing manoeuvres to ensure that the gate moves correctly and to check for installation or setting defects.

- 01.** Press “Open” and ensure that the opening manoeuvre comprises the acceleration phase, the constant speed phase and the deceleration phase. Check correct offset of the leaves on opening. At the end of the manoeuvre, the leaves must be perfectly open on the mechanical opening stop;
- 02.** Press the “Close” key and check that the closure manoeuvre includes the acceleration, constant speed and deceleration phases. Check that the leaf closure offset is correct. At the end of the manoeuvre, the leaves must be perfectly closed on the mechanical closure stop.
- 03.** Make sure that the flashing light flashes at intervals of 0.5 sec on, 0.5 sec off during manoeuvres.

These are the most important phases in the installation of the automation system, in order to guarantee maximum system safety. Testing can also be used to check the devices in the automation system regularly. The automation system testing and commissioning phases must be carried out by qualified experts who must be responsible for determining the tests necessary to check the solutions adopted vis-à-vis the risks involved, and to check the observance of all legal and regulatory obligations: in particular all the requirements of the EN 12445 standard which sets forth the test methods for checking automated gates.

Additional devices must undergo specific testing, both in terms of functionality as well as their correct interaction with POP; please refer to the relevant individual instruction manuals.

**5.1 - Testing**

The sequence of steps to take to carry out testing refers to a typical system (fig. 3):

- 1** Ensure that everything stated in the “Installation warnings” chapter has been observed.
- 2** Release the gearmotors manually and check that when you operate the leaf, at the point designed especially for the manual manoeuvre, the leaves can either be opened or closed with a force of less than 390 N.
- 3** Secure the gearmotors (see chapter 3.6).
- 4** Using the control devices (transmitter, command button, key selector, etc.), perform some Gate Opening, Closing and Stop tests, making sure the movement of the leaves corresponds with each test. It is a good idea to carry out several tests in order to evaluate the movement of the leaves and pinpoint any assembly or adjustment defects as well as to check for any particular points of friction.
- 5** Check operation of all system safety devices one at a time (photocells, sensitive edges etc.). When a device trips, the BLUEBUS™ led on the control unit emits 2 quick flashes to confirm recognition.
- 6** If the hazardous situations caused by the movement of the leaves have been safeguarded by limiting the force of impact, the force must be measured in accordance with the EN 12445 standard and, if necessary, if the control of the “gearmotor force” is used as an aid to the system to reduce the force of impact, try and then find the adjustment that achieves the best results.
- 7** Permanently affix a label showing how to manually release the gearmotor in a zone adjacent to the automation.

**5.2 - Commissioning**

**Commissioning can only take place once all the testing phases have been carried out successfully.**

- 1** Put together the automation system’s technical file, which should include the following documents: an overall diagram of the automation system, the diagram of the electrical connections made, the current risk analysis and the related solutions adopted, the manufacturer’s declaration of conformity for all the devices used and the declaration of conformity filled in by the installer.
- 2** Affix a data plate onto the gate which specifies the following information, at least: the type of automation system, the name and address of the manufacturer (responsible for the commissioning), the serial number, the year of manufacture and the EC mark.
- 3** Fill in the declaration of conformity of the automation system and hand it over to its owner.
- 4** Fill in and hand over to the owner of the automation system the “User’s guide” of the automation system.
- 5** Fill in and hand over to the owner of the automation system the “Maintenance schedule” which contains instructions on the maintenance of all the devices in the automation system.
- 6** Before commissioning the automation system, inform the owner of all the hazards and residual risks entailed.

For all the documentation mentioned, the Nice technical support service provides the following: instruction manuals, guides and precompiled forms. Also visit: [www.nice-service.com](http://www.nice-service.com)

## 6 PROGRAMMING THE CONTROL UNIT

The control unit has 3 keys **OPEN** (◀), **STOP (SET)**, **CLOSE** (▶) that can be used both for controlling the unit during testing and for programming the available functions.

The programmable functions available are divided into 2 levels and their relative operating status is displayed by means of the 8 LEDs (**L1**...**L6**) on the control unit (LED lit = function active; LED off = function not active).

### Use the programming keys:

**OPEN** (◀): – key for controlling gate opening; – selection key during programming.

**STOP/SET**: key for stopping a manoeuvre; if pressed for more than 5 seconds, it enables entry to programming mode.

**CLOSE** (▶): – key for controlling gate closure; – selection key during programming.

### 6.1 - Level one programming (ON-OFF functions)





All level 1 functions are set by default to “OFF” and may be modified at any time. To check the functions see **Table 5**. For the programming procedure see **Table 6**.

**IMPORTANT** – In the programming procedure, the maximum time interval that can elapse between activation of one key and the next is 10 seconds. When this time elapses, the procedure terminates automatically, memorising the modifications made up until then.

**TABLE 5 - First level functions**

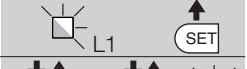
Led	Function	Description
L1	Automatic closure	<u>ACTIVE function</u> : after an opening movement, there is a pause (equal to the programmed time) after which the control unit automatic initiates a closure movement. The factory setting for the Pause time is 30 sec. <u>Function NOT ACTIVE</u> : function is “semiautomatic” type”.
L2	Reclose after photo	<u>ACTIVE function</u> : if the photocells are activated during the opening or closing manoeuvre, the pause time is reduced to 5 seconds regardless of the programmed pause time. With “automatic closure” disabled, if the photocells are activated during closure the “automatic closure” is activated with the programmed “pause time”.
L3	Always close	<u>ACTIVE function</u> : in the event of a power failure, even of short duration, when power is restored the control unit detects gate open and automatically starts a closure manoeuvre, preceded by 5 seconds of pre-flashing. <u>Function NOT ACTIVE</u> : when power is restored the gate remains where it is.
L4	All standby	<u>ACTIVE function</u> : after 1 minute from the end of the manoeuvre, the control unit turns off the “BlueBus” output (connected devices), Bus T4 (connected devices), the outputs flash and ELS, some internal circuits and all leds with the exception of the BlueBus led, which flashes at a slower interval. When the control unit receives a command, it resumes normal operation (after a short delay). This function is used to reduce consumption, an important aspect in the case of battery powered devices or when using photovoltaic panels.
L5	lock/Courtesy light	<u>ACTIVE function</u> : the “electric lock” output switches its operation to “courtesy light”. <u>Function NOT ACTIVE</u> : the output operates as an electric lock.
L6	Pre-flash	<u>ACTIVE function</u> : adds a pause of 3 seconds between switch-on of the flasher and the beginning of the manoeuvre, to signal a dangerous situation in advance. <u>Function NOT ACTIVE</u> : the signalling of the flasher coincides with the beginning of the manoeuvre.
L7	“Step-Step” becomes “Open” and “Open” becomes “Close”	<u>ACTIVE function</u> : the two inputs “Step-step” and “Open” of the control unit have the functions “Open” and “Close”. <u>Function NOT ACTIVE</u> : the two inputs “Step-step” and “Open” of the control unit have the functions “Step-step” and “Partial Open 1”.
L8	“Flash” or “Gate Open Indicator”	<u>ACTIVE function</u> : the “flash” output of the control unit switches operating mode to “gate open indicator”. <u>Function NOT ACTIVE</u> : the “FLASH” output of the control unit performs the “Flashing light” function”.

**TABLE 6 - Programming procedure (first level functions)**

<b>01.</b> Press and hold down the “Set” key for approx. 3 seconds;	
<b>02.</b> Release the key when LED “L1” starts flashing;	
<b>03.</b> Press the “◀” or “▶” key to move the flashing LED to the LED representing the function to be modified;	
<b>04.</b> Press “Set” to change the status of the function: ( short flash = OFF; long flash = ON);	
<b>05.</b> Wait 10 seconds (maximum time) to exit the programming mode.	
<b>Note</b> – During this procedure, points 03 and 04 need to be repeated when programming other functions to “ON” or “OFF” during the phase itself.	

### 6.2 - Level two programming (adjustable parameters)

All level 2 functions are set by default as highlighted in **grey** in **Table 7** and may be modified at any time as explained in **Table 8**.

The parameters can be set on a scale from 1 to 8. To check the value corresponding to each LED see **Table 10**. **IMPORTANT** – In the programming procedure, the maximum time interval that can elapse between activation of one

key and the next is 10 seconds. When this time elapses, the procedure terminates automatically, memorising the modifications made up until then.















TABLE 7 - Second level functions

Input LED	Parameter	Led (level)	Value	Description
<b>L1</b>	<b>Pause time</b>	L1	5 seconds	Sets the pause time, namely the time which lapses before automatic closure. This will only take effect if closing is active.
		L2	15 seconds	
		L3	30 seconds	
		L4	45 seconds	
		L5	60 seconds	
		L6	80 seconds	
		L7	120 seconds	
		L8	180 seconds	
<b>L2</b>	<b>Step by step function</b>	L1	Open – stop – close – stop	Sets the sequence of commands associated with the “Step-by-Step”, “Open”, or “Close” inputs or the radio control.  <b>Note – When setting L4, L5, L7 and L8, the behaviour of the “Open” and “Close” commands is also modified.</b>
		L2	Open – stop – close – stop	
		L3	Open – stop – close – stop	
		L4	Apartment block: <ul style="list-style-type: none"> <li>In the opening manoeuvre the “Step by Step” and “Open” commands have no effect; the “Close” command causes the movement to be inverted, i.e. the closure of the leaf.</li> <li>In the closure manoeuvre the “Step by Step” and “Open” commands cause the movement to be inverted, i.e. the leaf to open; the “Close” command has no effect.</li> </ul>	
		L5	Apartment block 2: <ul style="list-style-type: none"> <li>In the opening manoeuvre the “Step by Step” and “Open” commands have no effect; the “Close” command causes the movement to be inverted, i.e. the closure of the leaf. <b>If the transmitted command persists for more than 2 seconds, a “Stop” is performed.</b></li> <li>In the closure manoeuvre the “Step by Step” and “Open” commands cause the movement to be inverted, i.e. the leaf to open; the “Close” command has no effect. <b>If the transmitted command persists for more than 2 seconds, a “Stop” is performed.</b></li> </ul>	
		L6	Step-by-step 2 (less than 2 sec. generates partial opening )	
		L7	Hold-to-run: the manoeuvre is performed only if the transmitted command persists; if the command is interrupted the manoeuvre stops.	
		L8	Opening in semi-automatic mode, closing in hold-to-run mode	
<b>L3</b>	<b>Motor speed</b>	L1	Very slow	Sets the motor speed during normal travel.
		L2	Slow	
		L3	Medium	
		L4	Fast	
		L5	Very fast	
		L6	Extremely fast	
		L7	Fast opening, Slow Closing	
		L8	Extremely fast Opening, Medium Closing	
<b>L4</b>	<b>Motor discharge after closing</b>	L1	No discharge	Sets duration of “short inversion” of both motors after performing Close manoeuvre with the aim of reducing the final residual thrust.
		L2	Level 1 - Minimum discharge (about 100 ms)	
		L3	Level 2 - ...	
		L4	Level 3 - ...	
		L5	Level 4 - ...	
		L6	Level 5 - ...	
		L7	Level 6 - ...	
		L8	Level 7 - Maximum discharge (about 1 s)	
<b>L5</b>	<b>Motor force</b>	L1	Level 1 - Minimum Force	Adjusts the force of both motors
		L2	Level 2 - ...	
		L3	Level 3 - ...	
		L4	Level 4 - ...	
		L5	Level 5 - ...	
		L6	Level 6 - ...	
		L7	Level 7 - ...	
		L8	Level 8 - Maximum Force	
<b>L6</b>	<b>Pedestrian or partial opening</b>	L1	Pedestrian 1 (opening of leaf M2 to 1/4 of total opening)	Sets type of opening associated with “Partial open 1” command.  In levels L5, L6, L7, L8; “minimum” opening means the smaller opening out of M1 and M2; for example, if M1 opens to 90° and M2 opens to 110°, the minimum opening is 90°
		L2	Pedestrian 1 (opening of leaf M2 to 1/2 of total opening)	
		L3	Pedestrian 3 (opening of leaf M2 to 3/4 of total opening)	
		L4	Pedestrian 4 (Complete opening of leaf 2)	
		L5	Partial 1 (opening of two leaves to 1/4 of “minimum” opening)	
		L6	Partial 2 (opening of two leaves to 1/2 of “minimum” opening)	
		L7	Partial 3 (opening of two leaves to 3/4 of “minimum” opening)	
		L8	Partial 4 (opening of two leaves to “minimum” opening)	
<b>L7</b>	<b>Maintenance warning</b>	L1	500	Controls the number of manoeuvres: when this number is exceeded, the control unit signals an automation maintenance request; see paragraph 6.3.2. – Maintenance warning.
		L2	1000	
		L3	1500	
		L4	2500	
		L5	5000	
		L6	10000	
		L7	15000	
		L8	20000	

<b>L8</b>	<b>List of faults</b>	L1	Manoeuvre 1 result (most recent)	The type of fault that has occurred in the last 8 manoeuvres can be established  See TABLE 12 – Fault log.
		L2	Manoeuvre 2 result	
		L3	Manoeuvre 3 result	
		L4	Manoeuvre 4 result	
		L5	Manoeuvre 5 result	
		L6	Manoeuvre 6 result	
		L7	Manoeuvre 7 result	
		L8	Manoeuvre 8 result	

**Note** – The factory settings are highlighted in grey.

**TABLE 8 - Programming procedure second level functions**

<b>01.</b> Press and hold down the “Set” key for approx. 3 seconds.;	 3 s
<b>02.</b> Release the key when LED “L1” starts flashing;	 L1 
<b>03.</b> Press the “◀” or “▶” key to move the flashing LED to the LED representing the “input LED” of the parameter to be modified;	 or  
<b>04.</b> Press and hold the “Set” key through to completion of point 06;	
<b>05.</b> Wait approx. 3 seconds, until the LED representing the current level of the parameter to be modified illuminates;	
<b>06.</b> Press keys “◀” or “▶” to move the LED representing the value of the parameter;	 or  
<b>07.</b> Release the “Set” key;	
<b>08.</b> Wait 10 seconds (maximum time) to exit the programming mode.	 10 s

**Note** – During this procedure, points 03 to 07 need to be repeated when programming other parameters during the phase itself.

## 6.3 - Special functions

### 6.3.1 - Function: “Move anyway”

This function allows the automation to be operated even when any of the safety devices does not work correctly or is out of use. The automation can be controlled in the “hold-to-run”, mode. Proceed as follows:

- Send a command to operate the gate using a transmitter or a key selector, etc. If everything operates correctly, the gate will move normally, otherwise proceed as follows;
- within 3 seconds, activate the control again and keep it activated;
- after approximately 2 seconds, the gate will perform the required movement in “hold-to-run”; mode; i.e. the gate will continue to move only as long as the control is activated.

If the safety devices do not operate, the flashing light flashes a few times to indicate the kind of problem (see chapter 6 - Table 10).

### 6.3.2 - Function: “Maintenance warning”

This function serves to indicate when automation maintenance is required. The maintenance warning signal is emitted by a lamp connected to the “flash” or “els” output when this output is programmed as a “maintenance indicator light” The various light signals are shown in Table 9.

To program the limit value of the maintenance operations, see Table 7.

### 6.4 - Deleting the memory

To delete the control unit memory and restore all factory settings, proceed as follows:

press and hold keys “◀” and “▶” until leds L1 and L2 start flashing.

**TABLE 9 - “Maintenance light”**

Number of manoeuvres	Signal
Below 80% of the limit	Light on for 2 seconds at the start of the opening manoeuvre.
Between 81% and 100% of the limit	Light flashing for the entire duration of the manoeuvre.
Beyond 100% of the limit	Light flashing continuously.

## 7 WHAT TO DO IF... (troubleshooting guide)

Some devices are able to emit signals that serve to recognise their state of operation or possible faults.

If a flashing light is connected to the FLASH output on the control unit, it will flash at intervals of 1 second during a manoeuvre. If faults occur, the flashing light will emit a sequence of two shorter flashes separated by a 1 second pau-

se. **Table 10** shows the cause and solution for each type of signal. The LEDs on the control unit also emit signals. **Table 11** shows the cause and solution for each type of signal. It is possible to verify faults that have occurred during the last 8 manoeuvres. See **Table 12**.













**TABLE 10 - Flashing light signals (FLASH)**

Flashes	Problem	Solution
1 short flash 1 second pause 1 short flash	Bluebus system error	At the start of the manoeuvre, the devices connected to Bluebus do not correspond to those recognized during the self-learning phase. One or more devices may be disconnected or faulty; check and, if necessary, replace them. In case of modifications repeat the device self-learning process (see paragraph 4.6).
2 short flashes 1 second pause 2 short flashes	Photocell activated	One or more photocells do not enable movement or have caused a movement inversion during travel; check to see if there are any obstructions.
3 short flashes 1 second pause 3 short flashes	Function activation "Obstacle detection" by force limiter	During the movement, the motors encountered excessive resistance; identify the cause and if necessary increase the level of force of the motors.
4 short flashes 1 second pause 4 short flashes	STOP input activation	At the start of the manoeuvre or during the movement, the STOP input was activated; identify the cause.
5 short flashes 1 second pause 5 short flashes	Error on internal parameters in control unit	Wait at least 30 seconds, then try giving a command and if necessary turn off the power supply. If the condition persists, there may be a malfunction and the electronic board must be replaced.
6 short flashes 1 second pause 6 short flashes	Maximum limit of consecutive manoeuvres or manoeuvres per hour exceeded.	Wait a few minutes until the manoeuvre limiting device falls to below the maximum limit.
7 short flashes 1 second pause 7 short flashes	Electric circuits fault	Wait at least 30 seconds, then try sending a command and if necessary turn off the power supply. If the condition persists, there may be a malfunction and the electronic board must be replaced.
8 short flashes 1 second pause 8 short flashes	A command is already present that disables execution of other commands	Check the type of command that is always present; for example, it could be a command from a timer on the "open" input.
9 short flashes 1 second pause 9 short flashes	The automation has been blocked by a "Block automation" command	Release the automation by giving the "Automation release" command.

**TABLE 11 - Signals given by LEDs on control unit (fig. 14)**

LED	Problem	Solution
<b>BLUEBUS</b> Always off	Fault	Check that the control unit is powered. Check that the fuses have not blown: if they have, check the cause of the fault and replace with others with the same value
Always on	Serious fault	A serious fault has occurred: try disconnecting electrical power from the control unit. If the problem persists it will be necessary to replace the electronic board
1 flash per second	Everything normal	Control unit works correctly
2 quick flashes	Input status variation	Normal if one of the inputs (PP, STOP, OPEN, CLOSE) changes: photocells activated or a command given via a transmitter
Series of flashes separated by one second pause	Various	Refer to Table 10
<b>STOP</b> Always off	Activation of the devices connected to the STOP input	Check the devices connected to the STOP input
Always on	Everything normal	STOP input active
<b>S.S.</b> Always off	Everything normal	S.S. input not active
Always on	S.S. input activation	Normal if the device connected to the S.S. input is active
<b>OPEN</b> Always off	Everything normal	OPEN input not active
Always on	OPEN input activation	Normal if the device connected to the OPEN input is active
<b>L1 - L2</b> Slow flashing	Change in number of devices connected to Bluebus or device self-learning not performed	The device self-learning process must be performed (see paragraph 4.5)
<b>L3 - L4</b> Slow flashing	Change in self-learning of the motor types or the positions of the mechanical stops	Self-learning of the mechanical stop positions has not been performed (see paragraph 4.6)
<b>L5</b> Slow flash	All OK	The ELS output has been with a function different from "electric lock" and "courtesy light".
<b>L7</b> Slow flash	All OK	The inputs SS and OPEN have been assigned with a function different from "Step Step" and "Partial Open 1" or "open" and "close".
<b>L8</b> Slow flash	All OK	The FLASH output has been assigned with a function different from "Flashing Light" and "gate open indicator"

TABLE 12 - Fault log

01. Press and hold down the "Set" key for approx. 3 seconds;	 3 s
02. Release the key when LED "L1" starts flashing;	 L1 
03. Press keys "◀" or "▶" to move from the flashing LED to L8 LED ("input LED") for the "Fault log" parameter;	 or   L8
04. Press and hold the "Set" key through to completion of point 06;	
05. Wait approx. 3 seconds until the LEDs representing the levels corresponding to the manoeuvres with faults illuminate. The LED L1 indicates the result of the most recent manoeuvre while L8 indicates the eighth-to-last manoeuvre. If the LED is on this means that a fault has occurred; if the LED is off, everything is normal;	3 s 
06. Press keys "◀" and "▶" to select the required manoeuvre: the corresponding LED performs a number of flashes equal to those normally performed by the flashing light;	 and  
07. Release the "Set" key.	

## 8 FURTHER DETAILS

The following accessories are envisaged for HOPP (optional): receivers in the family SMXI, OXI, the programmer Oview, the solar power panel Solemyo and buffer battery mod. PS124.

### 8.1 - Connecting a radio receiver

The control unit has a connector for connecting radio receivers (optional accessories) belonging to the SMXI and OXI families. To connect a receiver, disconnect power from the control unit and proceed as shown in **fig. 16**. **Table 13** and

**Table 14** show the commands corresponding to the outputs on the control unit.

### 8.2 - Connection and installation of the back-up battery mod. PS124

**IMPORTANT! - The battery must only be connected to the control unit after all the phases of installation and programming have been completed, as the battery constitutes a source of emergency power.**

To arrange connection to the Solemyo system, follow the stages of assembly **fig. 17**.

TABLE 13

SMXI / SMXIS or OXI / OXIFM / OXIT / OXITFM in mode I or Mode II

Output N°1	"S.S." (Step by Step) command
Output N°2	"Partial opening 1" command
Output N°3	"Open" command
Output N°4	"Close" command

TABLE 14 - OXI / OXIFM / OXIT / OXITFM in extended mode II

N°	Command	Description
1	Step by step	"S.S." (Step by Step) command
2	Partial opening 1	"Partial opening 1" command
3	Open	"Open" command
4	Close	"Close" command
5	Stop	Stops manoeuvre
6	Apartment block	Apartment block control
7	Step by Step	Gives command even when automation is blocked or commands are in progress
8	Partial open 2	Partial open (Opening of leaf M2 to 1/2 of normal opening)
9	Partial open 3	Partial open (Opening of two leaves to 1/2 of normal opening)
10	Open and block	It causes an opening manoeuvre, after which the automation is blocked; the control unit accepts no further commands with the exception of "Step by step high priority", "Release" automation and (from Oview only) the commands "Release and close" and "Release and open"
11	Close and block	It causes a closure manoeuvre, after which the automation is blocked; the control unit accepts no further commands with the exception of "Step by step high priority", "Release" automation and (from Oview only) the commands "Release and close" and "Release and open"
12	Block automation	It causes the manoeuvre to stop and the automation to block; the control unit accepts no further commands with the exception of "Step by step high priority", "Release" automation and (from Oview only) the commands "Release and close" and "Release and open"
13	Release	It causes the automation to be released and normal operation to resume
14	On Timer Courtesy light	The Courtesy light comes on with timed turning off
15	On-Off Courtesy light	The Courtesy light turns on and off in step-by-step mode

### 8.3 - Connection of the Oview programmer

The control unit has a BusT4 connector to which the Oview programming unit can be connect, and which allows the complete rapid management of the installation and maintenance phase as well as the diagnosis of the entire automation system. To access this connector, proceed as shown in **fig. 18** and connect the connector to the dedicated seat. The Oview can be connected to several Control units simultaneously (up to 5 without any particular precautions, and up to 60 observing the dedicated warnings) and can stay connected to the control unit even during the normal operation of the automation system. In this case, it can be used to send the commands directly tot he control unit using the specific "user" menu. The Firmware upgrade can also be carried out. If there is a radio receiver from the OXI family in the control unit, Oview can be used to gain access to the parameters of the transmitters stored in the receiver itself. For further information, please consult the relevant instruction manual and the manual for the "Opera system book" system.

### 8.4 - Connecting the solar power system Solemyo

**CAUTION!** – When the automation is powered by the "Solemyo" system, IT MUST NEVER BE POWERED simultaneously by the electrical mains.

For more information on the Solemyo system, refer to the relative instruction manual.

To connect the Solemyo system, proceed as shown in **fig. 19**.

### 8.5 - Connecting the external release system Kio (fig. 20)

**CAUTION!** – Kio must be connected to the gearmotor controlling the leaf that moves first (starting from the gate closed position).

01. Remove the plastic cover (1);
02. Insert pin (3) in the hole of the release shaft (2);
03. Insert the steel cable (7) before the screw (4), then in the specific hole (5) and then in the hole of pin (3);
04. Hook up the spring (6) with the two ends positioned as shown in the figure;
05. Secure the cable by tightening the relative screw (4);
06. Route the other end of the cable through the hole on the lower section of the gearmotor;
07. Refit the plastic cover (1);
08. At this point, connect the cable to Kio, with reference to the relative instruction manual.

## 9 PRODUCT MAINTENANCE

In order to keep the safety level constant and to guarantee the maximum life span of the entire automation system, regular maintenance is vital.

All maintenance work must be carried out in compliance with the safety provisions of this manual and in accordance with existing laws and regulations.

The product requires frequent inspection to check for imbalances of the doors or signs of wear or damage to the cables. Do not use the product if adjustments or repairs are required.

**Important** – During the product maintenance or cleaning operations, cut off the electricity supply to the control unit and any batteries envisaged.

For the other devices in the system, follow the instructions provided in their respective maintenance schedules.

For gearmotors HO7124, HO7224, scheduled maintenance is required at the latest 6 months or 20,000 manoeuvres after the previous maintenance work.

Maintenance can be performed as follows:

01. Cut off any electrical power source, including any back-up batteries;
02. Check the condition and wear of brackets and fixing plugs, paying special attention to erosion or rusting; replace all parts which do not provide sufficient guarantees;

03. Perform a trial release to ensure it is working properly – see paragraph 3.6.
04. Reconnect the electrical power sources and perform all the checks envisaged in chapter 5 - Testing.

## DISPOSING OF THE PRODUCT

**This product is an integral part of the automation system, and should therefore be disposed of together with it.**

As for the installation operations, even at the end of this product's life span, the dismantling operations must be carried out by qualified experts.

This product is made up of various types of materials: some can be recycled while others need to be disposed of. Find out about the recycling or disposal systems envisaged by your local regulations for this product category.

**Important!** – Parts of the product could contain pollutants or hazardous substances which, if released into the environment, could cause harmful effects to the environment itself as well as to human health.

As indicated by the symbol opposite, throwing away this product as domestic waste is strictly forbidden. So dispose of it as differentiated waste, in accordance with your local regulations, or return the product to the retailer when you purchase a new equivalent product.



**Important!** – the local applicable regulations may envisage heavy sanctions in the event of illegal disposal of this product.

### Disposal of the back-up battery (where present)

**Important!** – The flat battery contains pollutants and should therefore not be thrown away as common waste.

It should be disposed of as differentiated waste, as envisaged by your local applicable regulations.

## TECHNICAL SPECIFICATIONS OF PRODUCT

**WARNINGS:** • All technical specifications stated in this section refer to an ambient temperature of 20°C (± 5°C). • Nice S.p.a. reserves the right to apply modifications to products at any time when deemed necessary, maintaining the same intended use and functionality.

	HO7124	HO7224
<b>Type</b>	Electromechanical gearmotor for automations of gates and automatic doors with DC motor, epicyclical gear reducer and mechanical release. Built-in control unit and OXI radio receiver.	Electromechanical gearmotor for automations of gates and automatic doors with DC motor, epicyclical gear reducer and mechanical release.
<b>Maximum torque</b>	250 Nm	
<b>Rated torque</b>	100 Nm	
<b>Speed under no load</b>	0,17 rad/s (1,6 rpm)	
<b>Speed at rated torque</b>	0,13 rad/s (1,2 rpm)	
<b>Maximum cycle frequency *</b>	35 cycles/hour	
<b>Maximum time of continuous cycle **</b>	10 minutes	
<b>Application limits</b>	the product can be used on gates with leaf weight up to 250 kg for lengths up to 1,5 m and weight up to 160 kg for lengths up to 2,4 m	
<b>Lifetime</b>	estimated between 80.000 cycles and 250.000 cycles, depending on the conditions reported in Table 15 and Graph 3	
<b>Power supply</b>	230 V~ (120 V~ for version <b>HO7124/V1</b> ) ±10%; 50/60 Hz	24 V=== (±25%)
<b>Back-up power supply</b>	provision for buffer battery PS124	
<b>Solar power</b>	provision for SYKCE kit	
<b>Maximum power absorption at rated torque</b>	170 W	50 W
<b>Peak power</b>	280 W	100 W
<b>Rated current absorption</b>	0,8 A (1,6 A for version <b>HO7124/V1</b> )	2 A
<b>Maximum current absorption</b>	1,3 A (2,6 A for version <b>HO7124/V1</b> )	4 A (for maximum time of 1 s)
<b>Absorbed power with "All - Standby" function when powered by PS124 or SYKCE kit (including OXI receiver)</b>	less than 100 mW	
<b>Flashing light output ***</b>	one LUCYB flashing light (12 V=== , 21 W)	
<b>Electric lock output ***</b>	one electric lock, 12 V~ max 15 VA	
<b>BLUEBUS output</b>	one output with load of maximum 15 Bluebus units (max. 6 pairs of MOFB or MOFOB photocells plus 2 pairs of MOFB or MOFOB photocells routed as opening devices plus max. 4 MOMB or MOTB control devices)	
<b>STOP input</b>	for normally closed contacts, normally open contacts or contacts with constant 8,2 kΩ resistance; selection of the type of contact is in self-learning mode and a modification with respect to the memorised status will generate a "STOP" command	
<b>SS input</b>	for normally open contacts (closure of the contact generates a Step Step command)	
<b>OPEN input</b>	for normally open contacts (closure of the contact generates a Partial Open 1 command)	
<b>Radio engage</b>	SM connector for receivers in the families SMXI, OXI and OXIFM	
<b>Radio AERIAL input</b>	50 Ω for cable type RG58 or similar	
<b>Programmable functions</b>	8 ON-OFF type functions (Table 5) and 8 settable functions (Table 6)	
<b>Self-learning Functions</b>	<ul style="list-style-type: none"> <li>• Self-learning of devices connected to the BlueBus output               <ul style="list-style-type: none"> <li>• Self-learning of the type of device connected to the "STOP" terminal (NO, NC contact or 8,2 kΩ)                   <ul style="list-style-type: none"> <li>• Self-learning of the gate leaf travel and automatic calculation of deceleration points and partial opening.</li> </ul> </li> <li>• Self-learning of operation with one or two motors</li> </ul> </li> </ul>	
<b>Assembly</b>	Vertical, with dedicated fixing plate	
<b>Operating temperature</b>	from -20°C to +50°C (at low temperatures, gearmotor efficiency is reduced)	
<b>Use in acid, saline or potentially explosive atmospheres</b>	NO	
<b>IP protection rating</b>	IP 54 (with container intact)	
<b>Dimensions (mm)</b>	180 x 252 x 290 h	
<b>Weight (kg)</b>	9	6,5

[\*] Cycle frequency at maximum temperature: 25 cycles/hour

[\*\*] Maximum continuous cycle time at maximum temperature: 8 minutes

[\*\*\*] The outputs Flashing Light and Electric lock can be programmed with other functions (see "TABLE 5 – Level 1 functions"; or via the Oview programmer; see chapter 8.3). The electrical specifications of the output are adapted to the type of selected function: • flashing light function: lamp 12 V=== , 21 W max; • electric lock function: 12 V~ 15 VA max; • other outputs (all types): 1 lamp or relay 24V=== (-30 to +50%), max. 4 W.

## PRODUCT LIFETIME

The lifetime is the average economic duration of the product. The value of lifetime is strongly influenced by the intensity of the manoeuvres performed by the automation. i.e. the sum of all factors that contribute to product wear (see Table 15).

To establish the probable lifetime of your automation, proceed as follows:

**01.** Calculate the severity index by adding all percentages of the items specified in **Table 15**;

**02.** In **Graph 3** from the value obtained above, trace vertical line until it intersects the curve; from this point trace a horizontal line until it intersects the line of the "manoeuvre cycles". The value obtained is the estimated lifetime of your product.

The estimation of lifetime is made on the basis of design calculations and the results of tests performed on prototypes. As it is only an estimation, it does not represent any form of guarantee on the effective lifetime of the product.

**Example of calculating the lifetime of a HOPP gearmotor (refer to Table 15 and Graph 3):**

- leaf length = 1,3 m (severity index: 15%);
- leaf weight: 180 Kg m (severity index: 30%);
- solid leaf (severity index: 15%);
- Total severity index = 60%;
- Estimated lifetime = 100.000 manoeuvre cycles

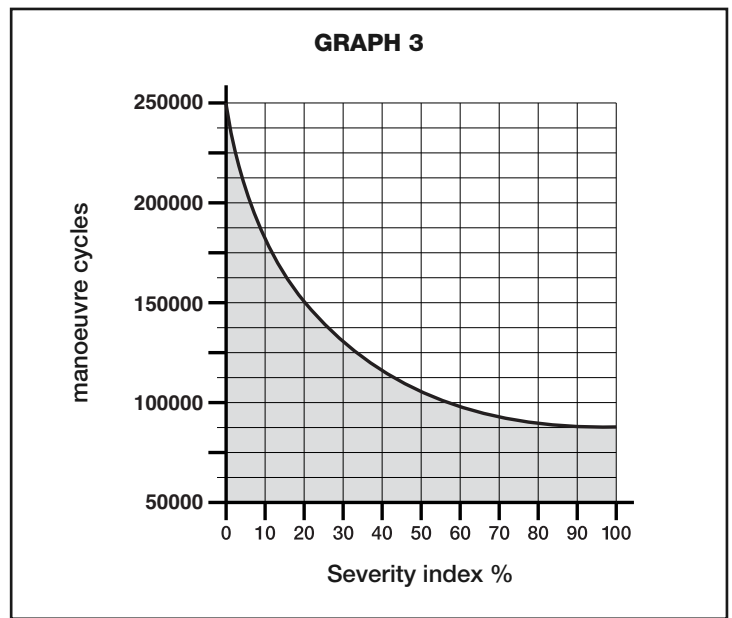

**TABLE 15**

		Severity index
<b>Leaf length</b>	< 1,0 m	-
	1,0 - 1,5 m	15%
	1,5 - 2,4 m	20%
<b>Leaf weight</b>	< 100 kg	-
	100 - 150 kg	20%
	150 - 250 kg	30%
<b>Ambient temperature above 40°C or below 0°C or humidity over 80%</b>		20%
<b>Solid leaf</b>		15%
<b>Installation in windy zone</b>		15%
<i>Note – The data refer to a balanced sectional door in perfect maintenance conditions</i>		

## CE DECLARATION OF CONFORMITY and declaration of incorporation of “quasi machinery”

Declaration in accordance with the Directives: 2004/108/EC (EMC); 2006/42/EC (MD) appendix II, part B

**Note** - The contents of this declaration correspond to declarations in the official document deposited at the registered offices of Nice S.p.a. and in particular to the last revision available before printing this manual. The text herein has been re-edited for editorial purposes.  
A copy of the original declaration can be requested from Nice S.p.a. (TV) I.

**Declaration number:** 376/HOPP

**Revision:** 0

**Language:** EN

**Manufacturer's Name:** NICE S.p.A.  
**Address:** Via Pezza Alta N° 13, 31046, Rustignè di Oderzo (TV) Italy  
**Person authorised to draw up technical documentation:** Mr. Oscar Marchetto  
**Address:** Via Pezza Alta N° 13, 31046, Rustignè di Oderzo (TV) Italy  
**Product type:** "HOPP" Electromechanical gearmotor with built-in control unit  
**Model / Type:** HO7124, HO7224  
**Accessories:** SMXI, OXI, PS124, Oview

The undersigned, Luigi Paro, in the role of Managing Director, declares under his sole responsibility, that the product specified above conforms to the provisions of the following directives:

- DIRECTIVE 2004/108/EC OF THE EUROPEAN PARLIAMENT AND COUNCIL of 15 December 2004 regarding the approximation of member state legislation related to electromagnetic compatibility, repealing directive 89/336/EEC, according to the following harmonized standards:  
EN 61000-6-2:2005, EN 61000-6-3:2007

The product also conforms to the following directive according to the requirements envisaged for “quasi machinery”:

- Directive 2006/42/EC THE EUROPEAN PARLIAMENT AND COUNCIL of 17 May 2006 regarding machinery and which amends directive 95/16/EC (recasting)
  - It is hereby declared that the pertinent technical documentation has been compiled in compliance with appendix VII B of directive 2006/42/EC and that the following essential requirements have been observed:  
1.1- 1.1.2- 1.1.3- 1.2.1-1.2.6- 1.5.1-1.5.2- 1.5.5- 1.5.6- 1.5.7- 1.5.8- 1.5.10- 1.5.11
  - The manufacturer undertakes to transmit to the national authorities, in response to a motivated request, all information regarding the “quasi-machine”, while maintaining full rights to the related intellectual property.
  - Should the “quasi machine” be put into service in a European country with an official language other than that used in this declaration, the importer is obliged to arrange for the relative translation to accompany this declaration.
  - The “quasi-machine” must not be used until the final machine in which it is incorporated is in turn declared as compliant, if applicable, with the provisions of directive 2006/42/EC.

The product also complies with the following standards:

EN 60335-1:2002 + A1:2004 + A11:2004 + A12:2006 + A2:2006 + A13:2008  
EN 60335-2-103:2003

The product also complies, within the constraints of applicable parts, with the following standards:

EN 13241-1:2003, EN 12445:2002, EN 12453:2002, EN 12978:2003

Oderzo, 24 January 2011

Ing. Luigi Paro (Managing Director)





**EN - Technical documentation**

*Images*

**IT - Documentazione Tecnica**

*Immagini*

**FR - Documentation Technique**

*Images*

**ES - Documentación Técnica**

*Imágenes*

**DE - Technische Dokumentation**

*Bilder*

**PL - Dokumentacja Techniczna**

*Zdjęcia*

**NL - Technische documentatie**

*Afbeeldingen*

# Instructions and warnings for the user

Before using the automation system for the first time, allow the installer to explain the origin of the residual risks and take a few minutes to read this instruction manual and the warnings for the user which the installer has handed you. Keep this manual in a safe place for future reference and hand it over to any new owner of the automation system.

**IMPORTANT! – Your automation system is a machine which performs the commands you send it; improper and careless use could make it become dangerous:**

- Do not operate the movement of the automation system if people, animals or objects lie in its range of action.
- It is strictly forbidden to touch parts of the automation system while the gate or door are in motion!
- The photocells are not a safety device but one that is auxiliary to safety. They are built with high reliability technology but they may, under extreme circumstances, malfunction or indeed fail and, in some cases, the failure may not immediately be visible. For these reasons, please observe the following warnings when using the automation system:
  - Transit is only permitted if the gate or door is completely open and with the leaves at a standstill
  - IT IS STRICTLY FORBIDDEN to transit while the gate or door is closing!
  - Ensure the photocells are working properly on a regular basis.

• **Children:** an automation system guarantees a high level of safety; indeed, thanks to its detection systems, it controls and guarantees movement in the presence of people or objects. It is however prudent to forbid children from touching or playing near the automation system and not to leave remote controls within their reach to avoid involuntary activation: **it is not a game!**

• The product is not intended for use by persons, including children, with limited physical, sensory or mental capacities, or who lack experience or knowledge, unless supervised or trained in the use of the product by a person responsible for their safety.

• **Faults:** if an operating fault is detected in the automation system, cut off the electricity supply to the automation system and release the gearmotor manually (see respective instruction manual) to operate the gate manually. Do not perform any repair work but contact your regular installer for assistance.

• **Do not change the system or the programming and adjustment parameters of the control unit: this lies within the area of responsibility of your installer.**

• **Breakage or lack of power supply:** while waiting for your installer to call by or for the power supply to be re-established, if the system is not equipped with a back-up battery, the automation system can still be used: simply perform the manual release of the gearmotor (see the respective instruction manual) and move the gate leaf manually as required.

• **Safety devices out of order:** the automation system can still work when a safety device doesn't work properly or is out of order. The gate can be controlled in "push to run" mode as follows:

01. Send a command to operate the gate, using a transmitter or key selector, etc. If everything is working properly, the gate will move normally, otherwise proceed as follows:
02. Within 3 seconds, send the command again and keep it activated;
03. After approximately 2 seconds, the gate will perform the manoeuvre requested in "push to run" mode; i.e. the gate will continue to move only for as long as the command is activated.

**N.B.!** – If the safety devices are out of order, we recommend you have them repaired as soon as possible by qualified experts.

• The testing, routine maintenance and any repair work must be documented by the person who carries out the work; the documents must be kept by the owner of the system. The only operations that the user can perform regularly are the cleaning of the glass covers of the photocells (use a slightly damp soft cloth) and the removal of any leaves or pebbles which could hamper the automation system. **Important** – Before going ahead, to prevent someone from being able to activate the gate inadvertently, release the gearmotor manually (see the respective instruction manual).

• **Maintenance:** in order to keep the safety level constant and to guarantee the maximum life span of the entire automation system, regular maintenance (at least every 6 months) is vital. **All control, maintenance or repair operations must only be carried out by qualified experts.**

• **Disposal:** at the end of the life span of the automation system, make sure that it is dismantled by qualified experts and that the materials are disposed of in accordance with the applicable local regulations.

• **If the automation system was secured with the command "Secure automation system":** after a command is sent, the gate does not move and the flashing light emits 9 brief flashes.

## MANUALLY RELEASING AND LOCKING THE GEARMOTOR

The gearmotor is equipped with a mechanical locking system to enable manual opening and closing of the gate.

These manual operations should only be performed in the event of a power failure, malfunctions or during the installation procedures.

**Releasing (fig. A):**

01. Insert the key;
02. Turn the key anti-clockwise (180°);
03. At this point the leaf can be moved manually to the required position.

**Locking (fig. B):**

01. Turn the key clockwise through 180°;
02. Remove the key.

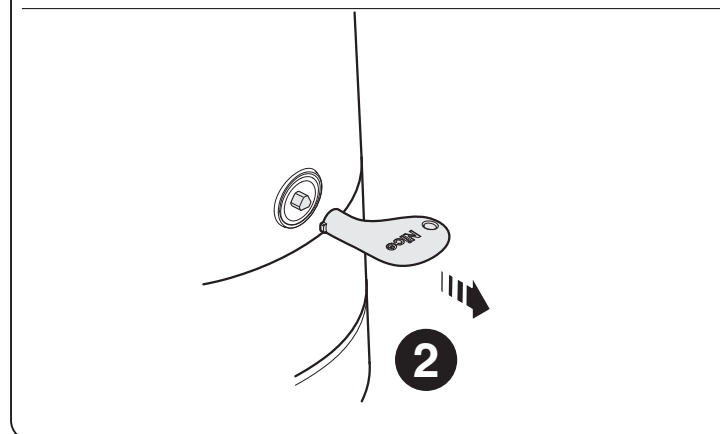
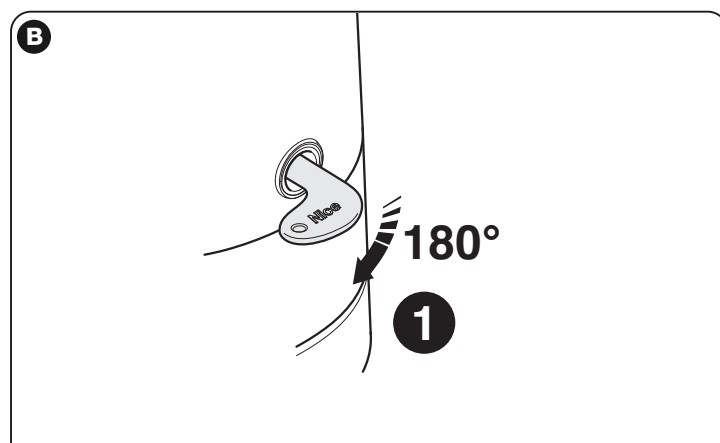
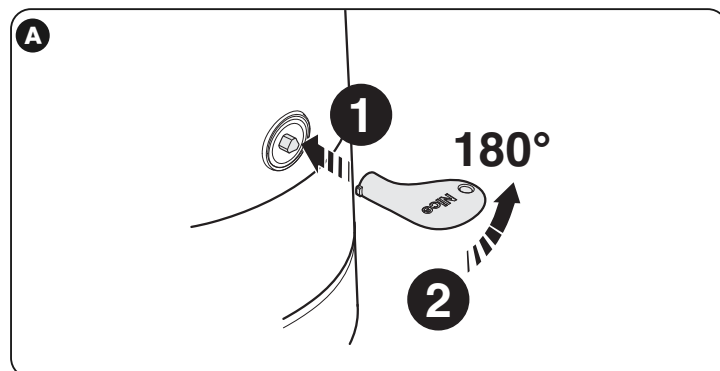

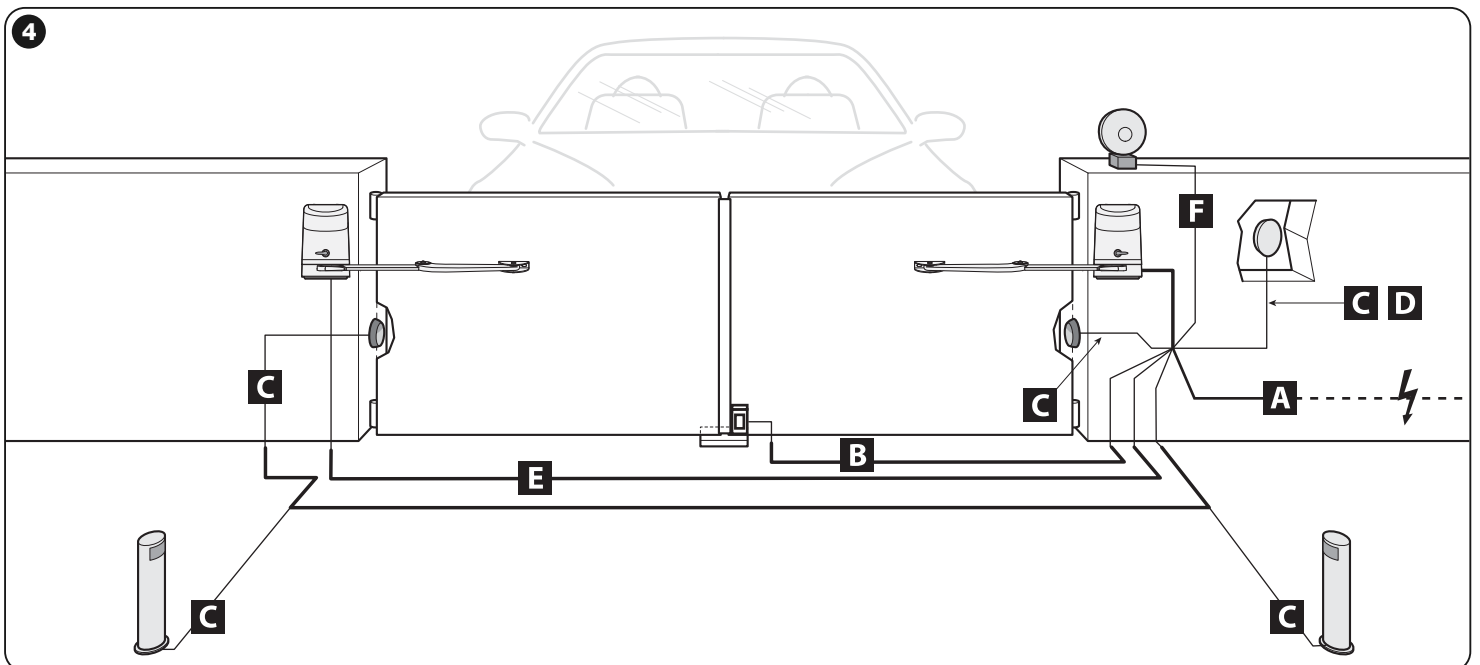
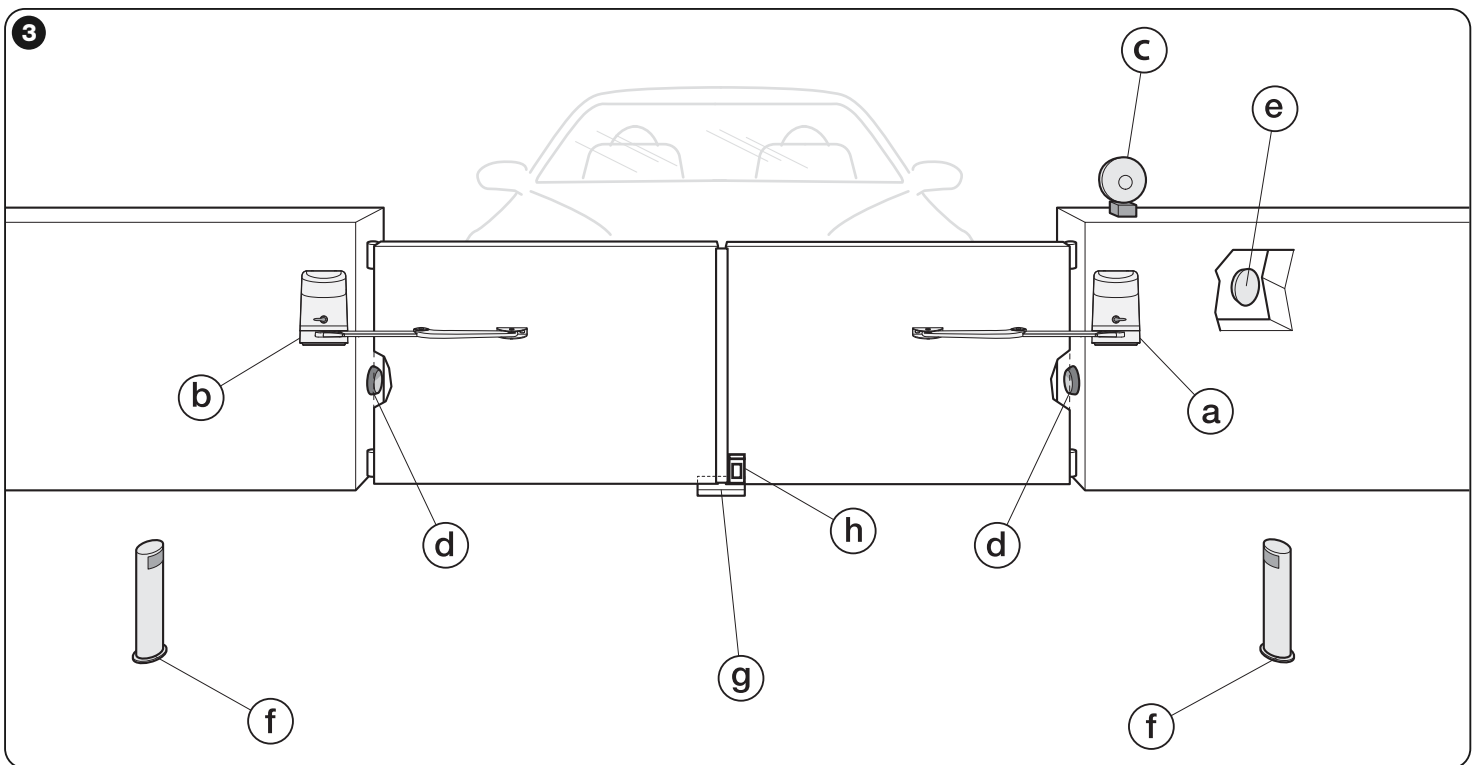
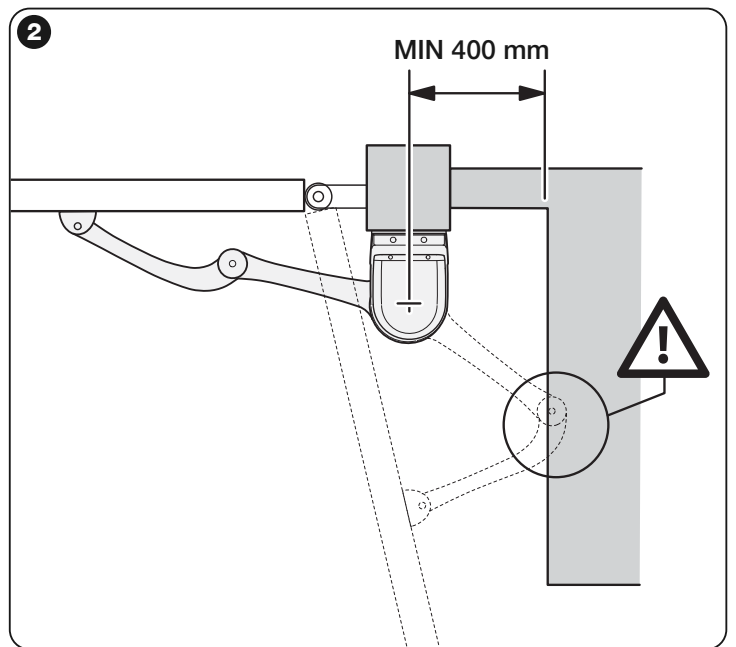
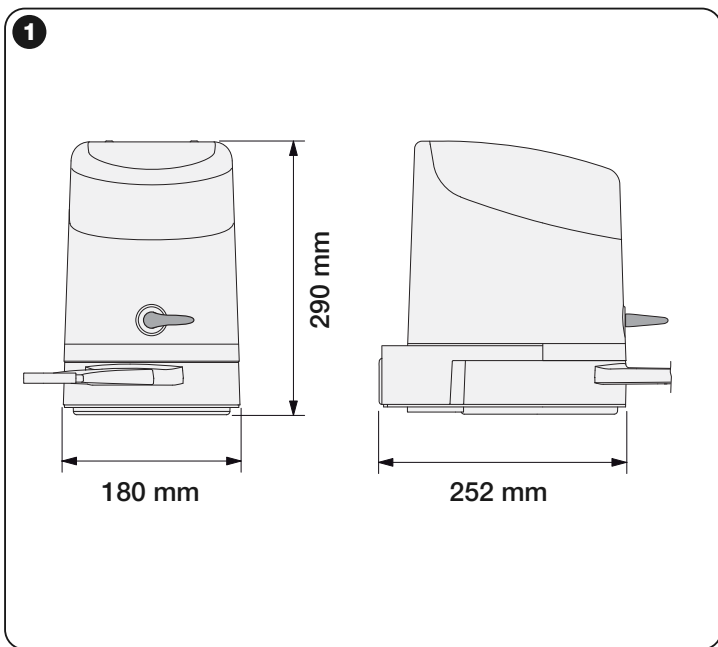

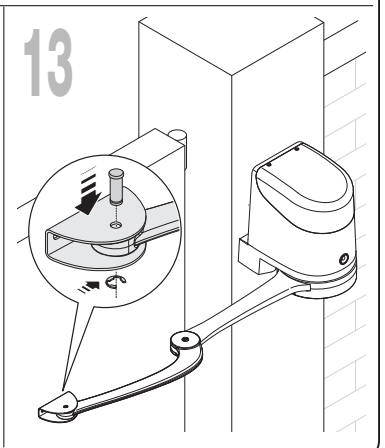
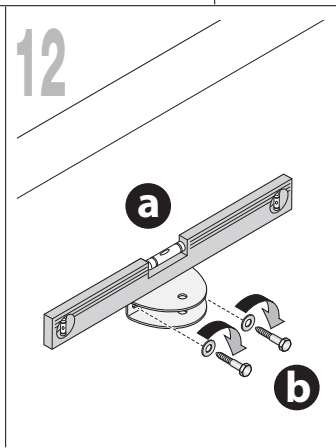
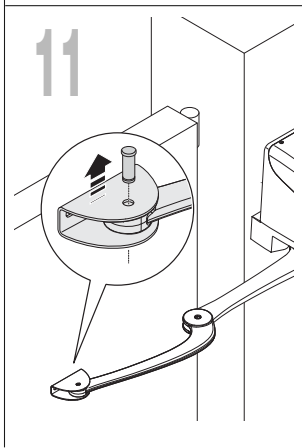
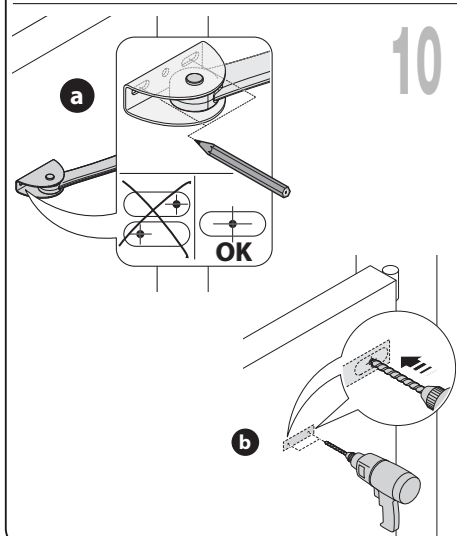
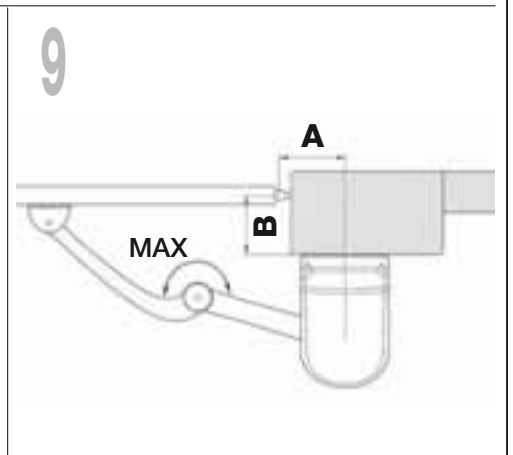
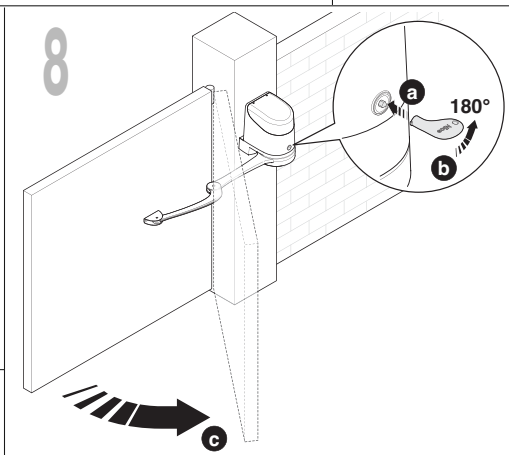
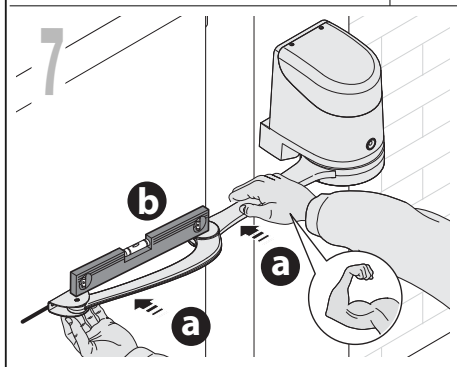
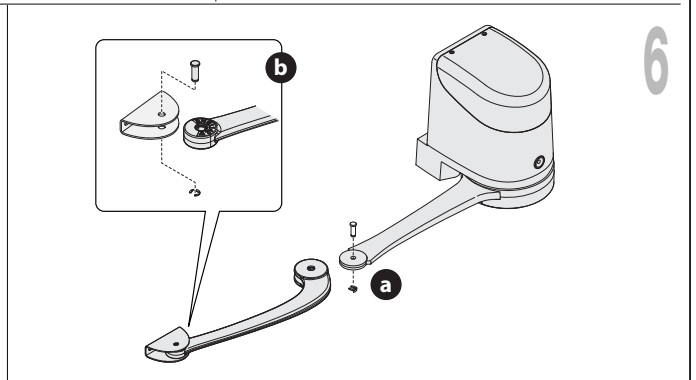
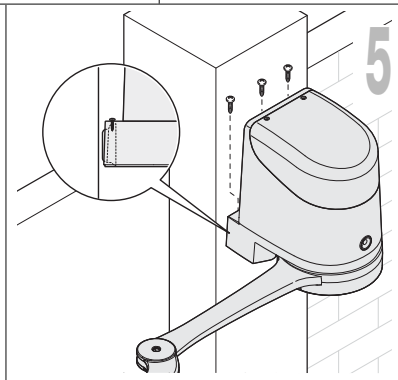
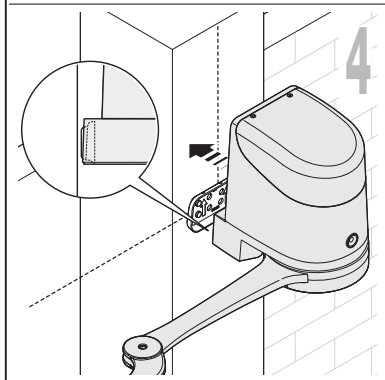
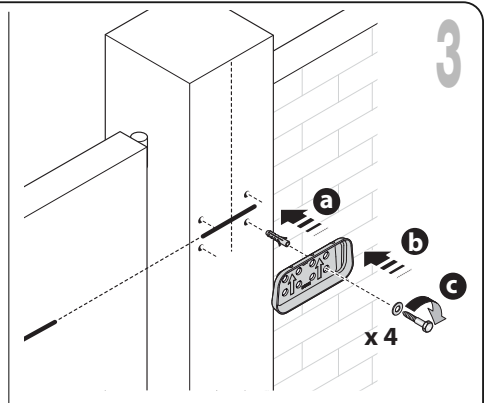
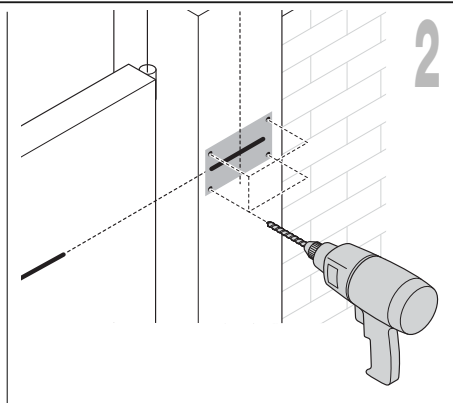
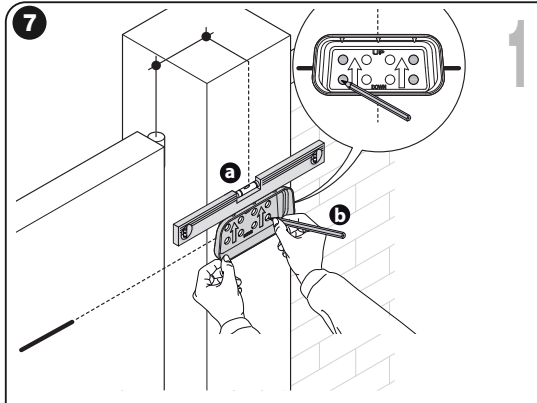
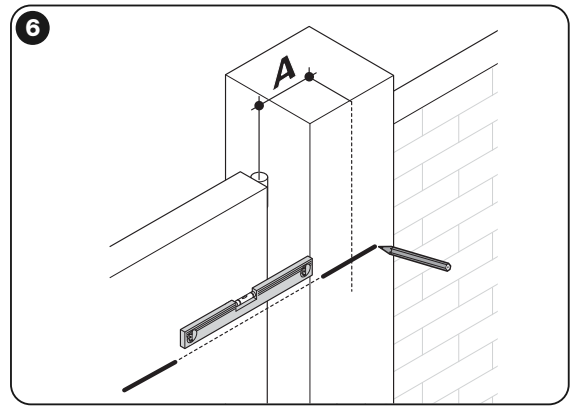
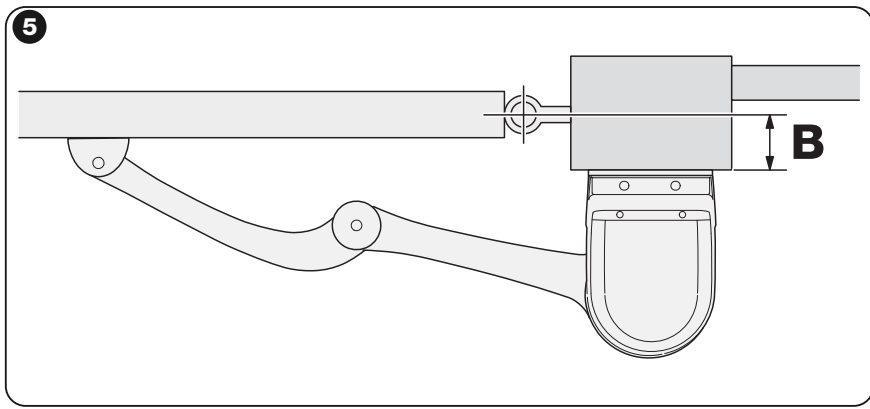

8

1

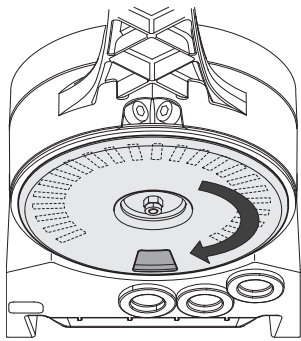

2

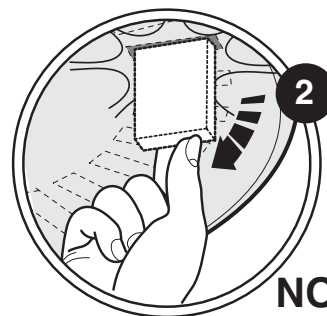
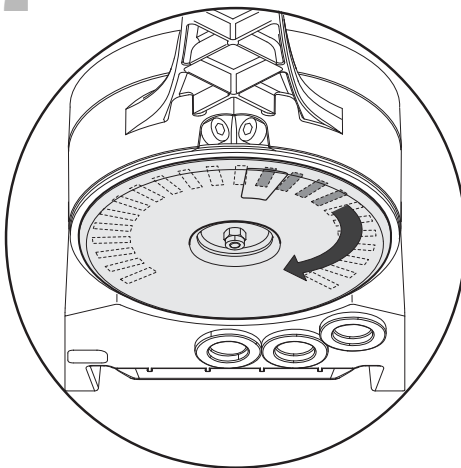

NO

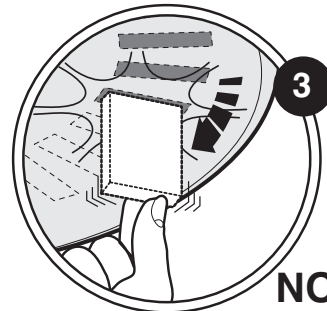

NO

3

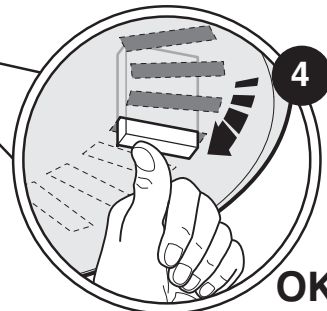
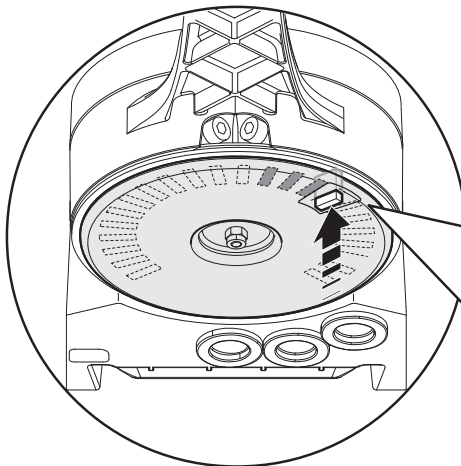
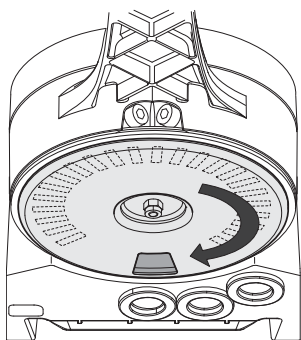

OK

4

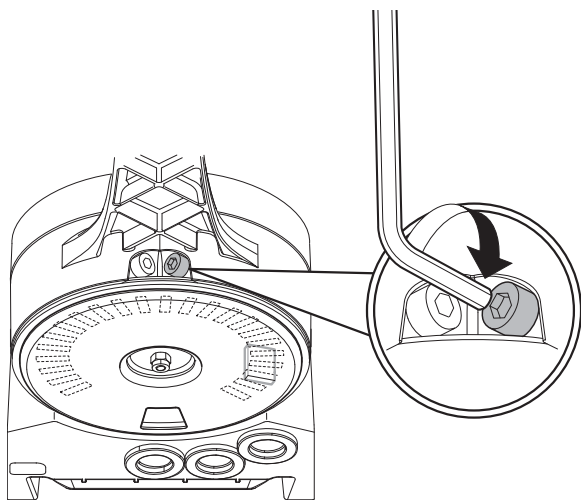

5

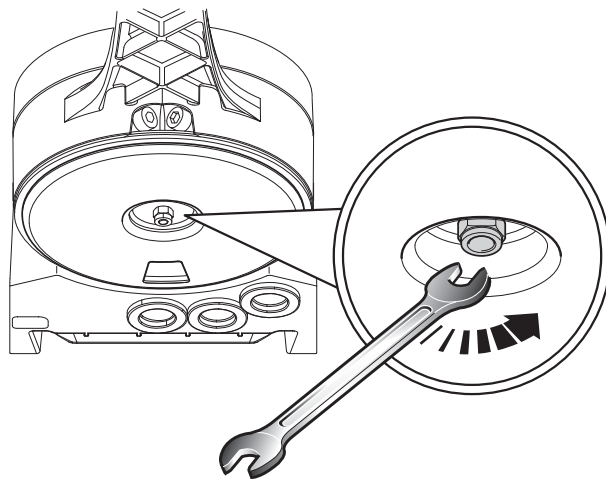

9

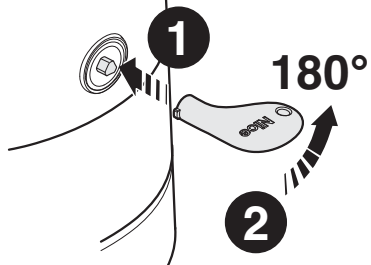

10

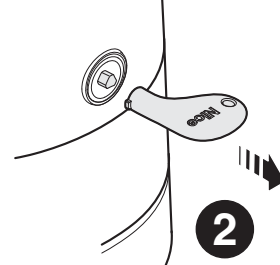
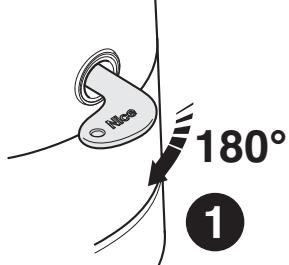

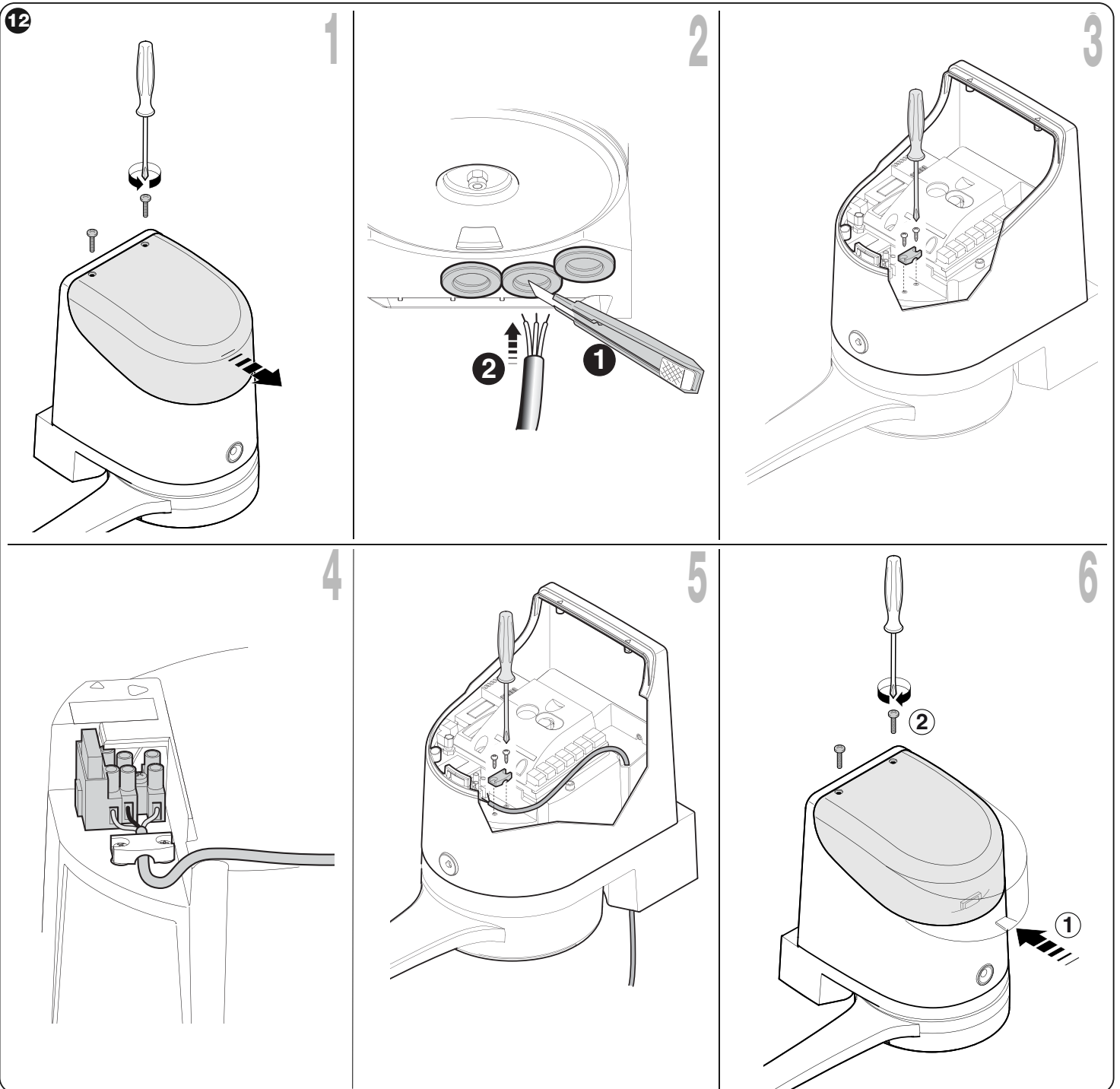
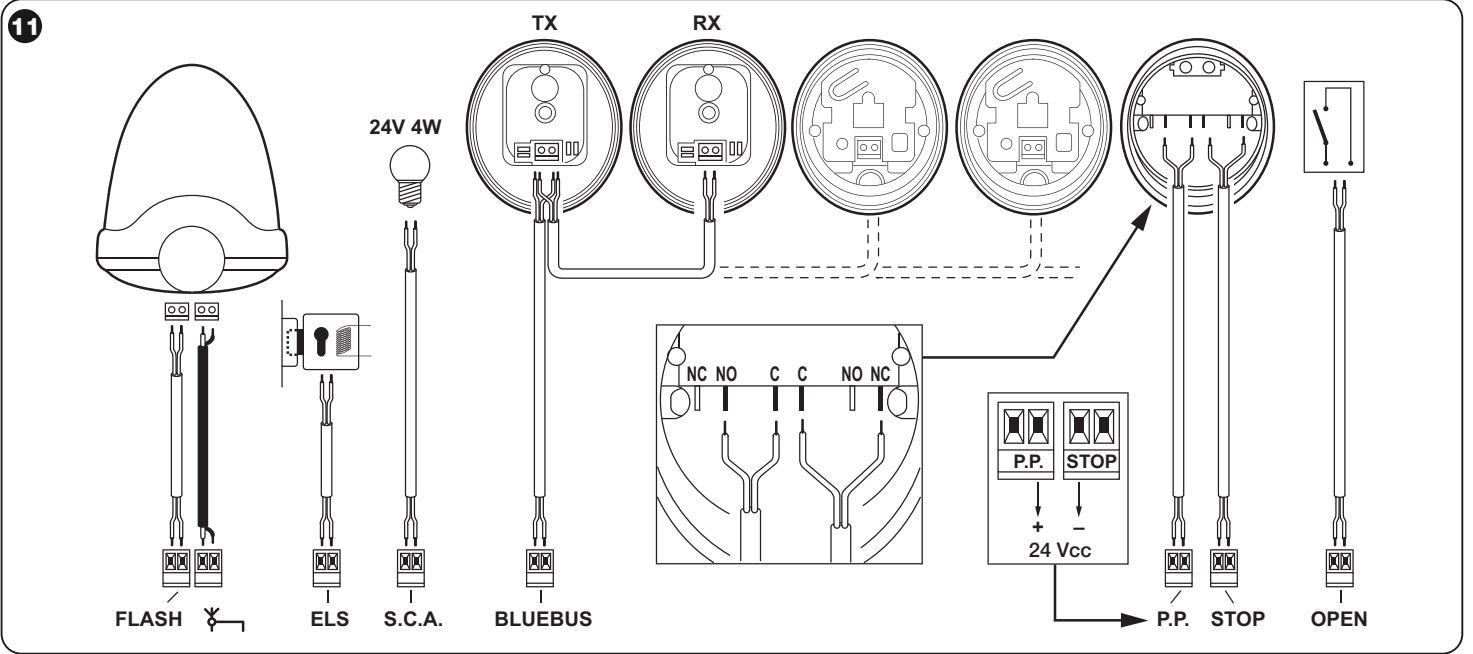

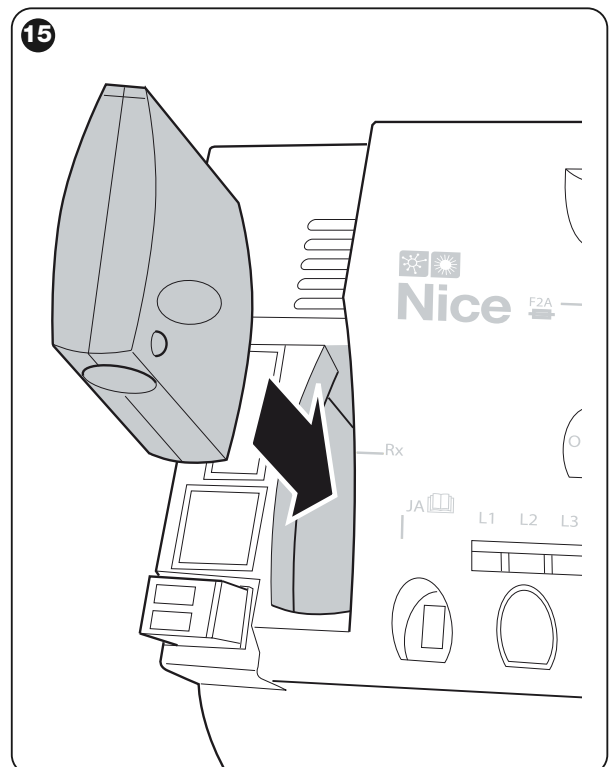
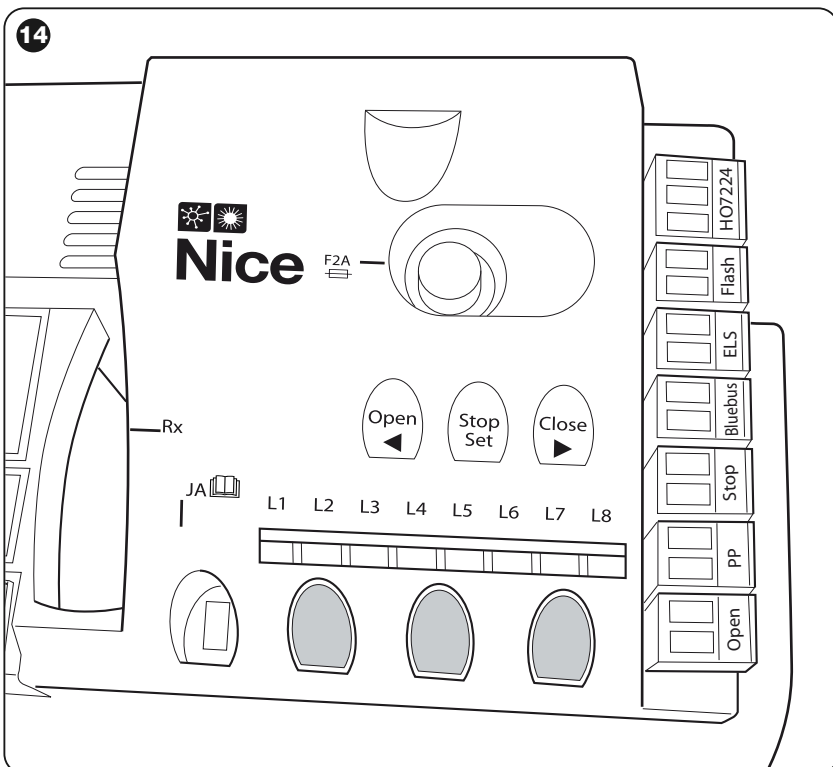
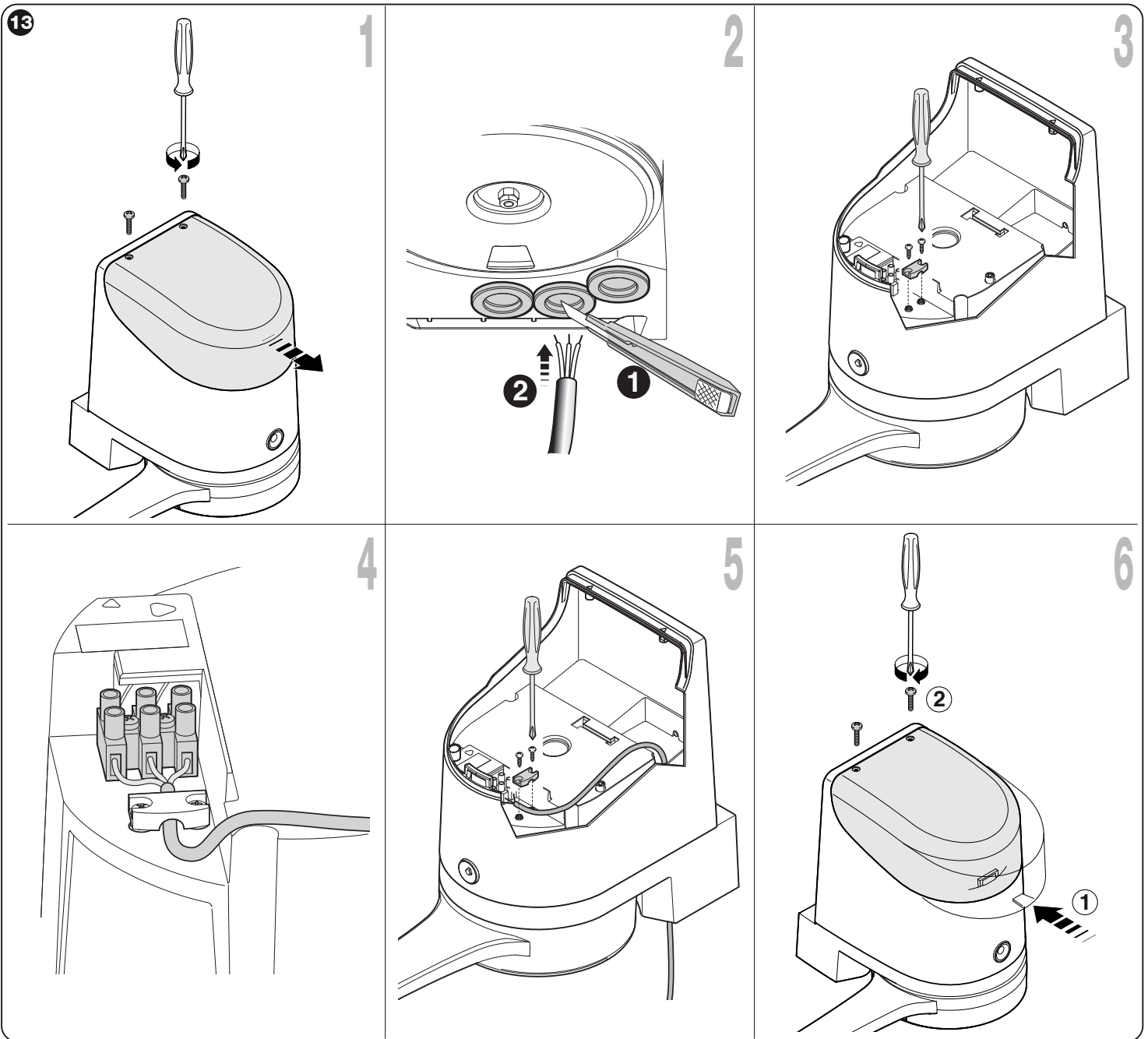

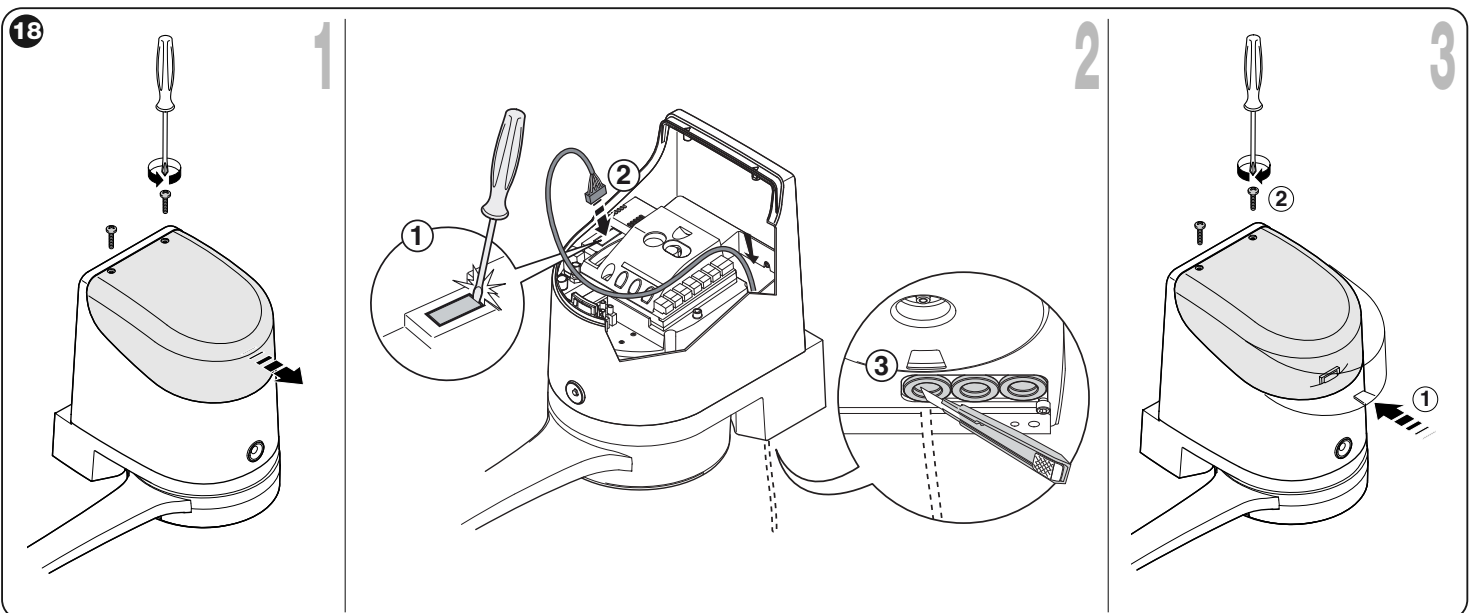
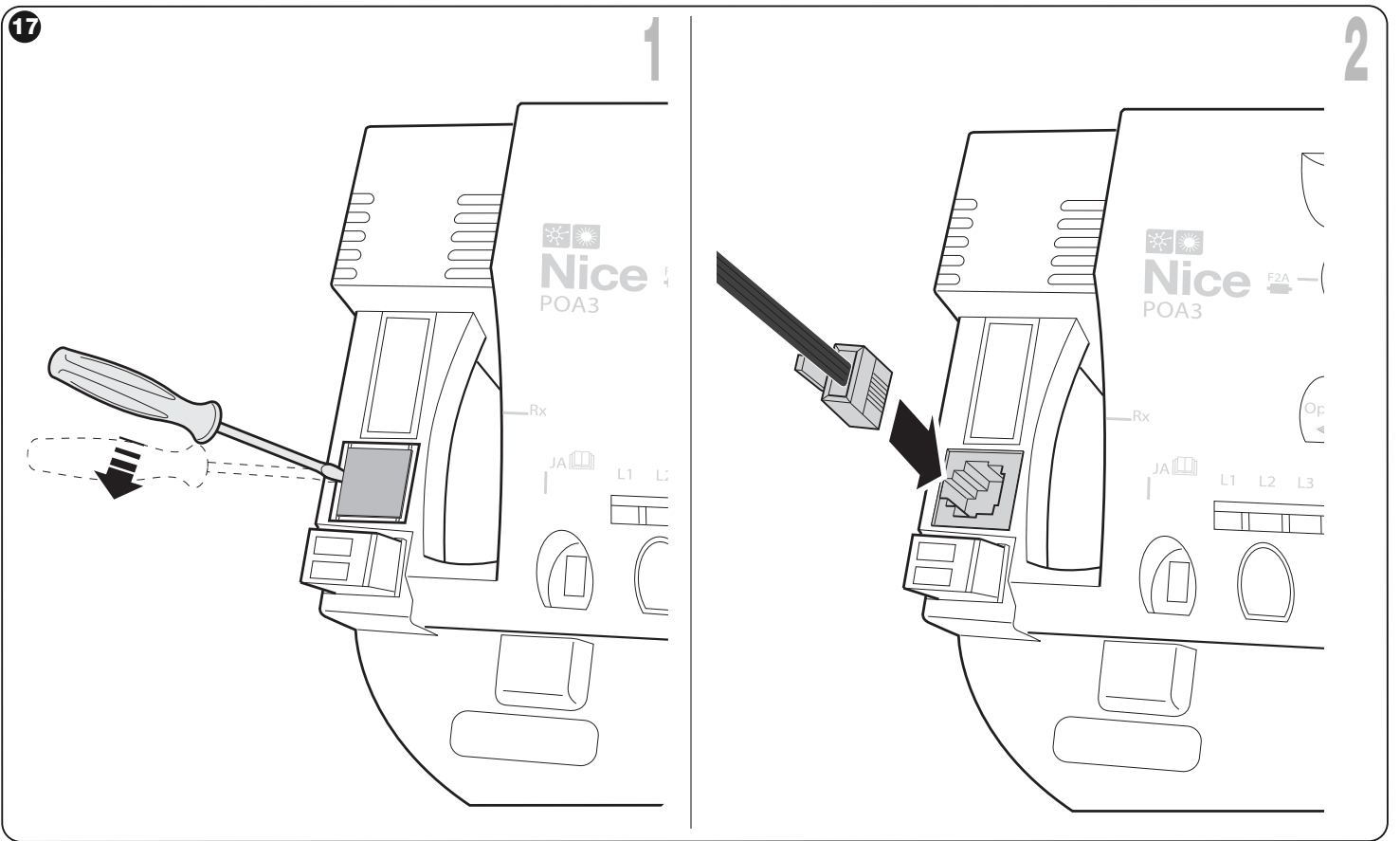
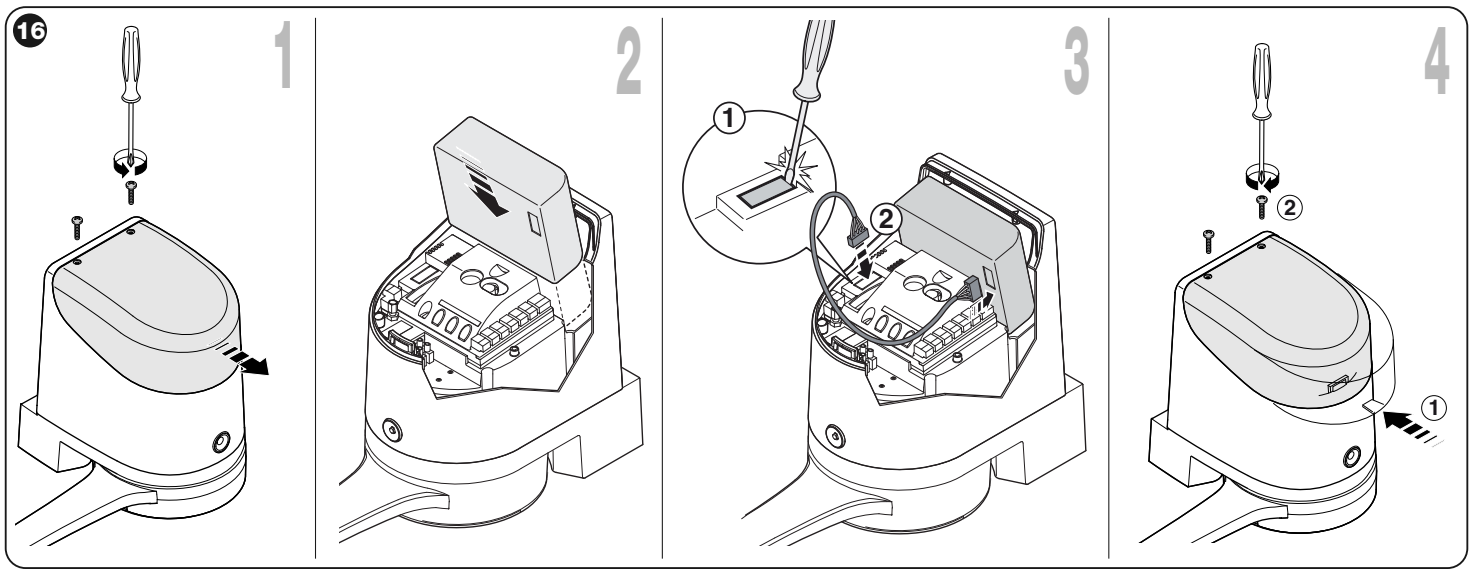



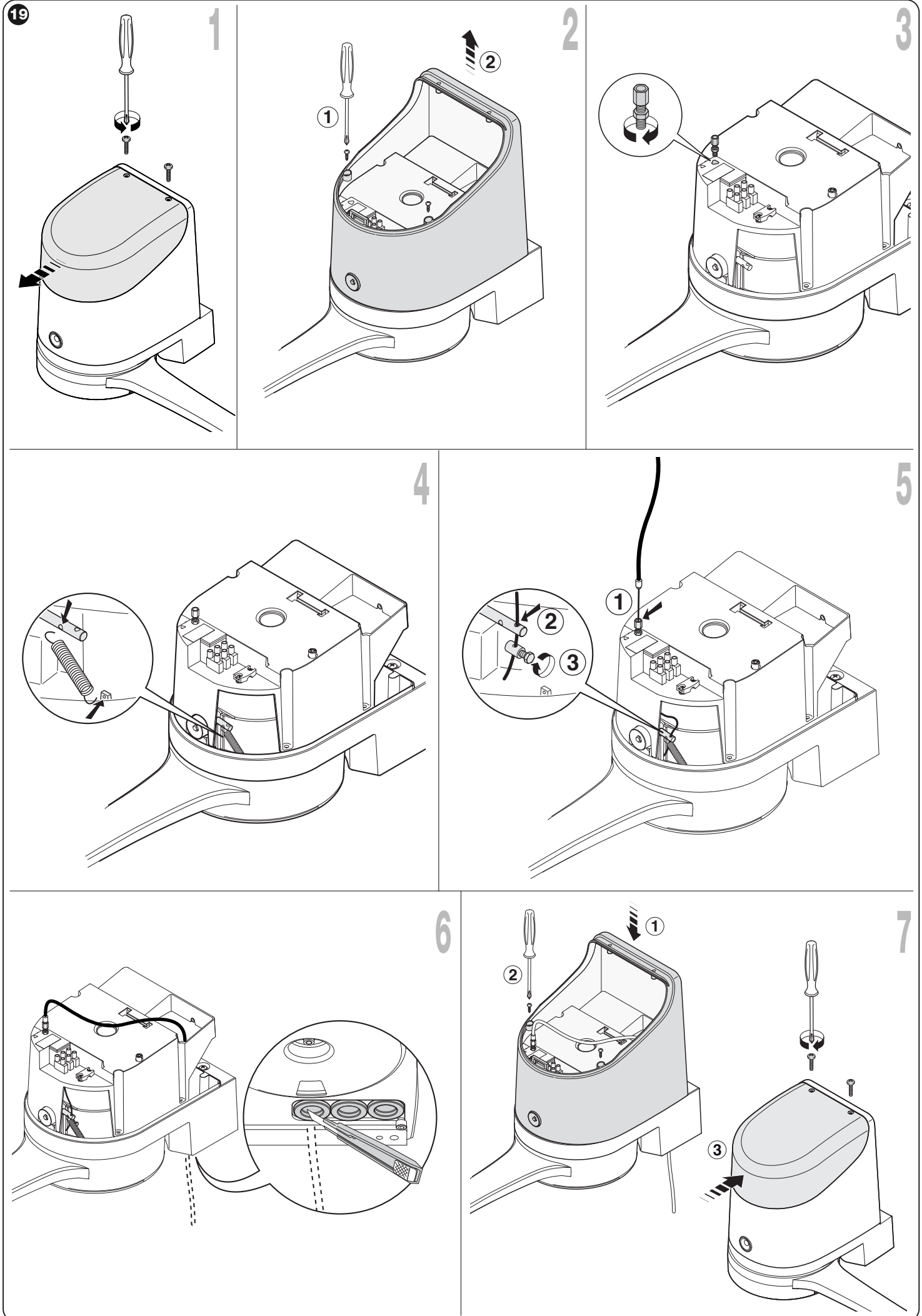



**Nice SpA**  
Oderzo TV Italia  
info@niceforyou.com

[www.niceforyou.com](http://www.niceforyou.com)