

Hyke

Swing gate opener

HK7024

HK7224

CE



EN - Instructions and warnings for installation and use

Nice

Contents

1 - WARNINGS AND GENERAL PRECAUTIONS	1
1.1 - Safety warnings.....	1
1.2 - Installation warnings.....	1
1.3 - Operation warnings.....	1
2 - PRODUCT DESCRIPTION AND INTENDED USE	1
3 - INSTALLATION	2
3.1 - Preliminary installation checks.....	2
3.2 - Application limits:.....	2
3.3 - Preliminary installation set-up work.....	2
3.4 - Installation of gearmotor mod. HK7024 - HK7224.....	2
3.5 - Mechanical limit switch adjustment.....	3
3.6 - Manually releasing and locking the gearmotor.....	4
4 - ELECTRICAL CONNECTIONS	4
4.1 - Electrical connections of gearmotor with control unit mod. HK7024.....	4
4.2 - Connection of gearmotor without control unit mod. HK7224.....	4
4.3 - Connection of other devices.....	4
4.4 - Routing connected devices.....	4
4.5 - Initial start-up and connection check.....	5
4.6 - Learning of the connected devices.....	5
4.7 - Mechanical limit switch positioning learning.....	5
4.8 - Gate leaf movement check.....	6
5 - TESTING AND COMMISSIONING	6
5.1 - Testing.....	6
5.2 - Commissioning.....	6
6 - CONTROL PANEL PROGRAMMING	7
6.1 - Level 1 programming (ON-OFF functions).....	7
6.2 - Level 2 programming (adjustable parameters).....	8
6.3 - Special functions.....	9
6.4 - Deleting the memory.....	9
7 - TROUBLESHOOTING... (troubleshooting guide)	9
8 - FURTHER INFORMATION	11
8.1 - Connecting a radio receiver.....	11
8.2 - Connecting and installing the buffer battery mod. PS124.....	11
8.3 - Connecting the Oview programmer.....	11
8.4 - Connecting the solar power system Solemyo.....	11
8.5 - Connecting the external release system Kio.....	11
9 - PRODUCT MAINTENANCE	12
PRODUCT DISPOSAL	12
Product lifetime	12
TECHNICAL SPECIFICATIONS OF PRODUCT	13
CE DECLARATION OF CONFORMITY	14
APPENDIX	I
Instructions and warnings for the user.....	II
Images.....	IX

1 WARNINGS AND GENERAL PRECAUTIONS

1.1 - Safety warnings

- **IMPORTANT!** – This manual contains important instructions and warnings regarding safety. Incorrect installation may cause serious injury. Before commencing work, all sections of the manual must be read carefully. If in any doubt, suspend installation and call the Nice Support Service for clarification.
- **IMPORTANT!** – This manual contains important instructions. Keep it for future maintenance work and disposal of the product.
- **IMPORTANT!** – Under the latest European legislation, automatic door and gate installations **must be compliant with the standards specified in Directive 2006/42/EC (formerly 98/37/EC) (the Machinery Directive) and the standards EN 12445, EN 12453, EN 12635 and EN 13241-1 in particular, which enable conformity of the automated functionality to be declared. In the light of the above, all work involving installation, connection, testing and maintenance of the product must be carried out exclusively by qualified and competent technicians!**

1.2 - Warnings for installation

- Before commencing the installation, check if the product is suitable for the desired type of use (see “Usage limitation” paragraph 3.2 and the “Product technical specifications”). If it is not suitable, DO NOT continue with the installation.
- The contents of this manual refer to a standard system as described in **fig. 3**.
- **All installation and maintenance work must be carried out with the automation system disconnected from the electricity supply.** If the power disconnection device cannot be seen from where the automation system is positioned, then before starting work a notice must be attached to the disconnection device bearing the words “CAUTION! MAINTENANCE IN PROGRESS”.
- The Control unit must be connected to an electricity supply line equipped with protective earthing.
- Handle the product with care during installation, taking care to avoid crushing, denting or dropping it, or contact with liquids of any kind. Keep the product away from sources of heat and naked flames. Failure to observe the above can damage the product, and increase the risk of danger or malfunction. Should this occur, suspend installation work immediately and contact the Nice Support Service.
- Do not modify any part of the product. Prohibited modifications can only lead to malfunctions. The manufacturer declines all responsibility for damage resulting from unauthorized changes made to the product.
- If the gate or door being automated has a pedestrian gate, then the system must include a control device that will inhibit the operation of the motor when the pedestrian gate is open.
- The product’s packaging material must be disposed of in full compliance with local regulations.

1.3 - Warnings for use

- The product is not intended for use by persons, including children, with limited physical, sensory or mental capacities, or who lack experience or knowledge, unless supervised or trained in the use of the product by a person responsible for their safety.
- Any children near the automation system must be kept under supervision to ensure that they do not play with it.
- Do not allow children to play with the fixed control devices. Keep remote control devices out of the reach of children.

2 PRODUCT DESCRIPTION AND INTENDED USE

The devices comprising this product are designed to automate a gate or door with one or two leaves. **IMPORTANT! – Any other use apart from that described herein, including in different environmental conditions from those described in this manual is to be considered improper use and is not permitted!**

The principal component of the automation system comprises one or two electric gearmotors (according to the number of leaves to be automated), each equipped with a direct current motor and epicyclic reduction gear. One of the gearmotors (mod. HK7024) has a control unit that controls its operation. The Control unit consists of a board with a radio receiver for receiving the commands sent by the transmitter.

The control unit is designed for connection to several devices belonging to the Opera system, the Bluebus system and the Solemyo solar powered system, see chapter 8 - Further information

If it is mains powered, it can house a back-up battery (mod. PS124, optional accessory) which in the event of a power cut (electricity black-out) guarantees that the automated device will perform certain manoeuvres in the hours that follow. In the event of a power cut, the gate leaves can be moved by releasing the gearmotor with the dedicated key; to perform the manoeuvre manually please see chapter 3.6.

Other available accessories include the receivers designed with “SM” connectors (SMXI, OXI, etc.), see chapter 8 - Further information.

3.1 - Pre-installation checks

Before going ahead with the installation, check the integrity of the product components, and ensure the model chosen is suitable for its intended use and for the environment in which it is to be installed.

- Check that all the material to be used is in excellent condition and suitable for its intended use.
- Check that the ground-mounted mechanical stops (not supplied), are present both when opening and closing the automation system.
- Check that the mechanical structure of the gate is suitable for the installation of automation and compliant with locally applicable regulations (if necessary, refer to the label on the gate). This product cannot be used to automate a gate which is not already in good, safe working order, neither can it fix faults caused by incorrect installation or poor maintenance of the gate.
- Check that the operating conditions of the devices are compatible with the usage limitation declared (see paragraph 3.2).
- Move the gate leaves manually in both directions and ensure that the resistance to movement is constant at all points of travel (there should not be any points where more force or less is required).
- Bring the gate leaves manually into a position at random, then let go and check that they remain stationary.
- Check that the gearmotor fixing zone is compatible with its overall dimensions (fig. 1).
- Check that the place where the gearmotor is to be installed allows enough space for its arm to execute its full range of movement.
- Check that there is sufficient room around the gearmotor for it to be released manually when required.
- Ensure that the surfaces on which the various devices are to be installed are strong and capable of ensuring a firm hold.
- Ensure that each device is installed in a position which is protected and does not expose it to accidental impacts.
- Ensure that all the electrical cables to be used are the type listed in Table 1.

3.2 - Application limits

Before installing the gearmotor, ensure that the specifications meet the requirements in terms of application limits as stated below and within the limits as specified in "Product Technical Specifications".

With the LONG motor arm :

- maximum leaf width: 3.50 m (= maximum leaf weight: 200 kg)

With the SHORT motor arm :

- maximum leaf width: 3.00 m (= maximum leaf weight: 180 kg)

- Checks to perform: note on Graph 1 alongside, the weight and width of the leaf; trace two lines from this point and check that these intersect within one of the two grey areas of the graph. **Caution!** - If the lines intersect in the white area, this product cannot be used to automate the gate.
- To enable installation of the gearmotor, the minimum column width must be 210 mm.
- The arm fixing bracket must be located in a resistant area of the leaf (for example the frame), to guarantee a solid and safe fixture;
- Check position "E" (fig. 2):
 - If position "E" is between 300 mm (minimum) and 650 mm (maximum), the gearmotor arm must be set at the SHORT length. In these conditions, the maximum leaf opening can reach 90°.
 - If position "E" is equal to or over 650 mm, the gearmotor arm must be set at the LONG length. In these conditions, the maximum leaf opening can reach 110°.

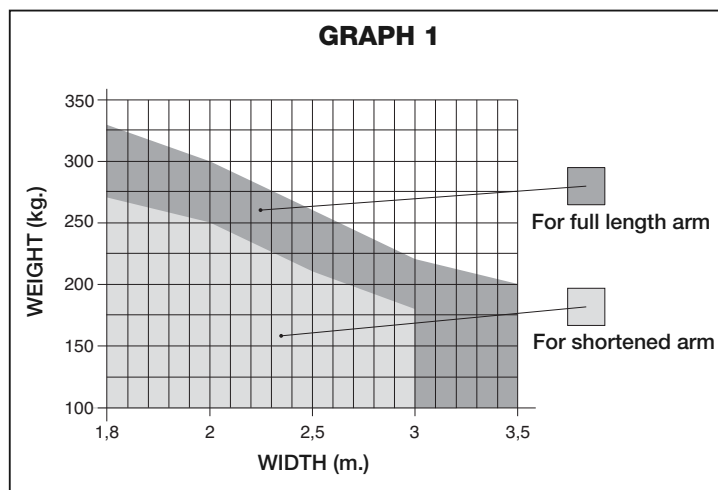

3.3 - Preliminary installation set-up work

Fig. 3 provides an example of an automation system, produced using Nice components (some components may not be present in the kit):

- a - Gearmotor with control unit model HK7024
- b - Gearmotor without control unit model HK7224
- c - Flashing light
- d - Pair of photocells model MOFB
- e - Digital keypad (mod. MOTB) - Transponder badge reader (mod. MOMB) - Key-operated selector switch (mod. MOSE)
- f - Pair of posts for photocells
- g - Mechanical stop on closing
- h - Electric lock

These parts are positioned according to a typical standard layout. With reference to fig. 3, locate the approximate position for installation of each component envisaged in the system. **Important** – Before installation, prepare the electric cables required for the system, with reference to fig. 4 and "Table 1 - Technical specifications of electric cables".

Caution – When laying the ducting for routing the electrical cables, also take into account that due to possible deposits of water in the routing ducts, the connection pipelines must not create condensate in the control unit, with consequent damage to the electronic circuits.

3.4 - Installation of gearmotor mod. HK7024 - HK7224

WARNINGS

- Incorrect installation may cause serious physical injury to those working on or using the system.
- Before starting automation assembly, make the preliminary checks as described in paragraphs 3.1 and 3.2.

Before starting installation, determine the length of the gearmotor arm with reference to paragraph 3.4.1.

3.4.1 - Determining the length of the gearmotor arm

01. Assemble the components of the motor arm as shown in fig. 5.
02. Establish the position of the gearmotor in the VERTICAL direction: on the column, trace a horizontal line at the same height as the designated position of the fixing bracket for the arm on the leaf after installation (fig. 6).
03. Establish the position of the gearmotor in the HORIZONTAL direction (position A):
 - CAUTION!** – If there is a fixed obstacle (wall, tree, etc.) in the vicinity of the installation area, measure value E (fig. 2) and proceed as follows:
 - if value E is equal to or greater than 650 mm, refer to paragraph 3.4.2

TABLE 1 - Technical specifications of electric cables (fig. 4)

Connection	Cable type	Maximum admissible length
A: Cable CONTROL UNIT POWER SUPPLY	1 Cable 3 x 1,5 mm ²	30 m (note 1)
B: ELECTRIC LOCK Cable	1 Cable 2 x 1 mm ²	6 m
C: BLUEBUS DEVICE cable	1 Cable 2 x 0,5 mm ²	20 m (note 2)
D: KEY-OPERATED SELECTOR SWITCH cable	2 Cables 2 x 0,5 mm ² (note 3)	50 m
E: GEARMOTOR POWER SUPPLY Cable ENCODER CONNECTION cable	1 Cable 3 x 1,5 mm ² (note 4) 1 Cable 2 x 1 mm ² (note 4)	10 m 10 m
F: FLASHING LIGHT with aerial cable	1 Cable 2 x 0,5 mm ² 1 RG58 type shielded cable	20 m 20 m (less than 5 m recommended)

Note 1 – If the power cable exceeds a length of 30 m, use a cable with a larger section (3x2.5 mm²); in this case earthing is required in the vicinity of the automation.

Note 2 – If the Bluebus cable exceeds a length of 20 m, up to a maximum of 40 m, use a cable with a larger section (2 x 1 mm²).

Note 3 – These 2 cables may be replaced with a single cable of 4 x 0,5 mm².

Note 4 – These cables may be replaced with a single cable of 5 x 1,5 mm².

CAUTION! – The cables used must be suited to the type of environment of the installation site.

- if value E is between 300 mm (minimum) and 650 mm (maximum), refer to paragraph 3.4.3

3.4.2 - Installing the gearmotor with the LONG MOTOR ARM LENGTH

01. a) On the column, measure **value B** (fig. 7) = distance between the leaf rotation fulcrum and the column surface designated for fixture of the rear gearmotor bracket.

b) Move the leaf to the required opening position (maximum 110°): value of angle.

c) On Graph 2 note the obtained **value B** and from this point, trace a horizontal line until it intersects the **area** covering the angle value measured in point b.

d) At the points of intersection between the horizontal line and the area, trace vertical lines to determine the feasible values for **value A** (fig. 8). Then choose a value for A within this range.

e) On the column, mark the value found for **value A** and trace a vertical line at this point.

02. Fixing the bracket on the column (fig. 9):

f) phases 1-2: Place the bracket on the column, aligning its vertical centreline with the previously traced vertical line (value A), and its arm with horizontal line traced during procedure 3.4.1. In this phase, ensure that the gearmotor is perfectly level: an offset gearmotor can cause automation malfunctions.

g) phases 3-4: Mark the fixing points, drill the holes in the column and insert the plugs, and then secure the bracket using suitable screws and washers.

03. Fixing the gearmotor arm on the leaf:

h) Move the gate leaf to the maximum closing position;

i) phase 5: Fix the gearmotor to the bracket with the two screws and nuts supplied;

l) Release the gearmotor; see chap. 3.6;

m) phase 6: Firmly push the gearmotor arm to its maximum extension. **Caution!** - Ensure that the arm stops and locks in place at its travel limit;

n) Move the arm towards the leaf, and position the fixing bracket on the leaf.
o) phase 7: Ensure that the gearmotor arm is perfectly level and use a pencil to mark the centre of the profile of the slots on the bracket, to enable future fine adjustment of leaf closure (see paragraph 4.8).

p) Use one hand to keep the bracket in contact with the leaf and perform a complete opening and closing cycle.

q) phase 8: Drill the leaf at the marked points, remove the bracket from the arm and fix it on the gate leaf with suitable screws.

r) phase 9: Fix the arm to the bracket, inserting the pin and Benzing snap ring. **Important** – Check that the bracket and arm are perfectly level. If necessary, loosen the screws and level correctly.

s) Position the mechanical limit stops with reference to chap. 3.5;

t) phase 10: Lastly, manually move the gate leaf to approx. mid-travel and block the gearmotor with the relative key (see chap. 3.6). Then manually move the gate leaf by a few centimetres in the opening direction.

04. If the gate to be automated is a two-leaf model, repeat the same operations as described in this chapter 3.4 to install the second gearmotor.

3.4.3 - Installing the gearmotor with the SHORT MOTOR ARM LENGTH

Caution! – In this configuration, the maximum admissible leaf opening is 90°.

01. a) On the column, measure **value B** (fig. 7) = distance between the leaf

rotation fulcrum and the column surface designated for fixture of the rear gearmotor bracket.

b) On Graph 2 note the obtained **value B** and from this point, trace a horizontal line until it intersects the **area** covering the range 90° - 95°.

c) At the points of intersection between the horizontal line and the area, trace vertical lines to determine the feasible values for **value A** (graph 2). Then choose a value for A within this range.

d) On the column, mark the value found for **value A** and trace a vertical line at this point.

02. Fixing the bracket on the column (fig. 10):

e) phases 1-2: Place the bracket on the column, aligning its vertical centreline with the previously traced vertical line (value A), and its arm with horizontal line traced during procedure 3.4.1. In this phase, ensure that the gearmotor is perfectly level: an offset gearmotor can cause automation malfunctions.

f) phases 3-4: Mark the fixing points, drill the holes in the column and insert the plugs, and then secure the bracket using suitable screws and washers.

g) Move the gate leaf to the maximum closing position;

h) phase 5: Fix the gearmotor to the bracket with the two screws and nuts supplied;

i) Release the gearmotor; see chap. 3.6;

03. Check the length of the slotted arm with respect to the configuration:

l) phase 6: Move the arm towards the leaf, and position the fixing bracket on the leaf. **Caution!** - manually push the curved arm against the leaf until the arm is locked in place (maximum opening).

m) phase 7: Ensure that the gearmotor arm is perfectly level and use a pencil to mark the centre of the profile of the slots on the bracket, to enable future fine adjustment of leaf closure (see paragraph 4.8).

n) Provisionally secure the bracket on the leaf and move the latter to the maximum opening position.

04. Fixing the gearmotor arm on the leaf:

o) phase 8: Drill the leaf at the previously marked points.

p) phases 9-10: Remove the bracket from the arm and fix it on the gate leaf with suitable screws.

q) phase 11: Fix the arm to the bracket, inserting the pin and Benzing snap ring. **Important** - Check that the bracket and arm are perfectly level. If necessary, loosen the screws and level correctly.

r) Position the mechanical limit stops with reference to chap. 3.5;

s) phase 12: Lastly, manually move the gate leaf to approx. mid-travel and block the gearmotor with the relative key (see chap. 3.6). Then manually move the gate leaf by a few centimetres in the opening direction.

05. If the gate to be automated is a two-leaf model, repeat the same operations as described in this chapter 3.4 to install the second gearmotor.

3.5 - Mechanical limiter adjustment

01. Manually move the gate leaves to the maximum opening position;

02. Rotate the plastic disk on the lower section of the gearmotor, to position the aperture under the arm as shown in fig. 11-1;

03. Insert the limiter in the first possible place: try to insert as shown in fig. 11-2 (opening direction);

04. Rotate the disk to prevent the limiter from dropping, moving the aperture to the position shown in fig. 11-3; for more precise adjustments, use the adjustment screw (fig. 11-4);

05. If there is no floor-mounted stop in the system, this procedure must be repeated from point 01 also for the closing limiter.

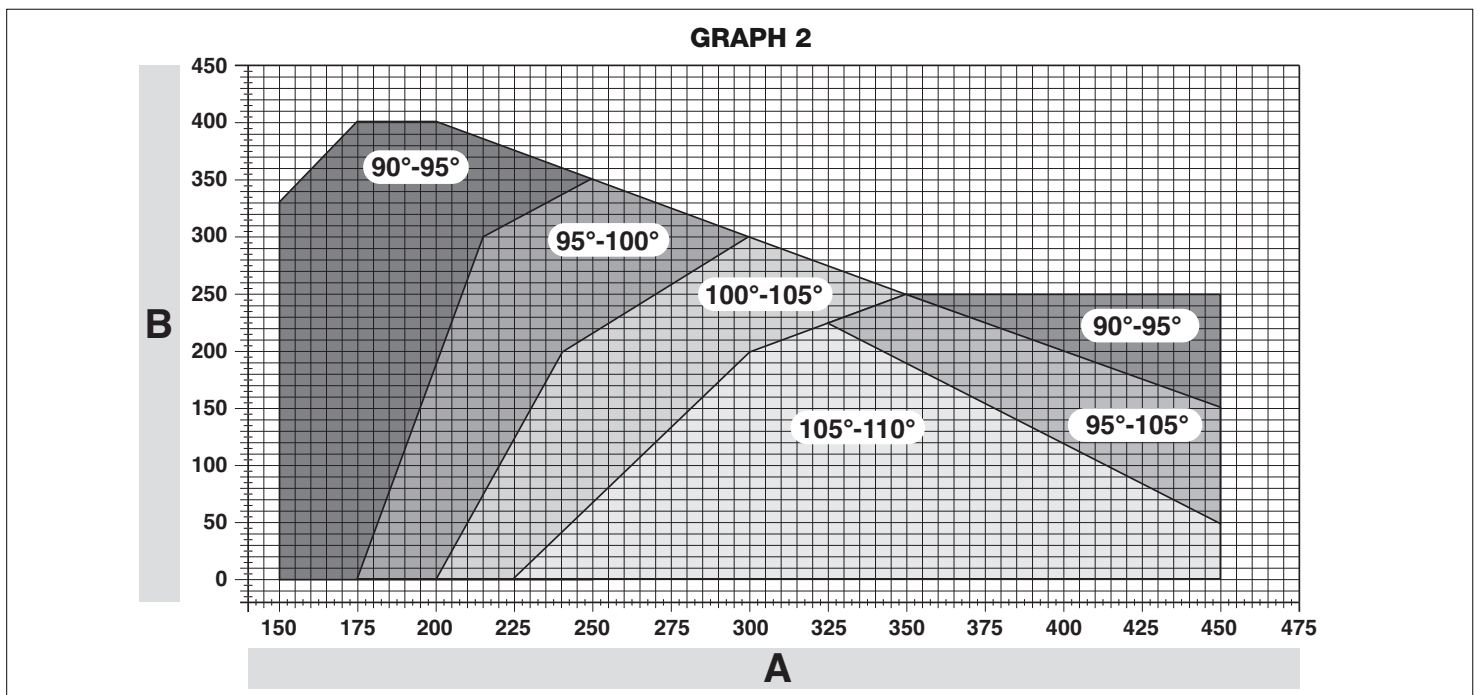

06. Lastly, tighten the disk fixing nut fully down (fig. 11-5) to ensure that it does not rotate accidentally.

3.6 - Manually releasing and locking the gearmotor

The gearmotor is equipped with a mechanical blocking system to enable manual opening and closing of the gate.

These manual operations should only be performed in the event of a power failure, malfunctions or during the installation procedures.

Release (fig. 12-A):

01. Insert the key in the relative lock;
02. Turn the key clockwise (90°);
03. The lever comes out under action of a spring: turn the lever anti-clockwise through 90°;
04. At this point the leaf can be moved manually to the required position.

Lock (fig. 12-B):

01. Turn the lever through 90° to place the stem in a vertical position;
02. Push the lever back into its seat;
03. Turn the key anti-clockwise through 90° and remove.

4 ELECTRICAL CONNECTIONS

The electrical connection of the various devices (photocells, digital keyboard, transponder card readers, etc.) contained in the automation with the control unit must be made by means of the Nice "Bluebus" system.

Description of electrical connections (fig. 13)

AERIAL	input for the radio receiver aerial
FLASH	output for 1 flashing light with 12V (maximum 21W) bulb. [*]
ELS	output for 12Vac (maximum 15VA) electric lock. [*]
S.C.A.	"Open Gate Light": output for 1 indication lamp (24V maximum 4W). [*]
BLUEBUS	input for compatible devices (MOFB, MOFOB, MOB and MOTB); they are connected in parallel using two conductors through which both the electricity supply and the communication signals travel; no polarity needs to be observed. The electrical connection to be used is of the parallel type and no polarity needs to be observed. During the learning stage, the control unit will recognise individually all devices connected to it thanks to a unique code. Each time a device is added or eliminated, it will be necessary to make the control unit perform the learning operation (see paragraph 4.6).
STOP	input for devices that cause the immediate interruption of the manoeuvre in progress (with a short reverse run); NO and NC contacts, as well as devices with 8.2 kΩ constant resistance output (sensitive edges) can be connected to this input. Each device connected to this input is recognised individually by the control unit during the learning stage (paragraph 3.4); in this stage, if the control unit detects any variations with respect to the learned state, it causes a STOP. One or more devices of the same or different kinds can be connected to this input: <ul style="list-style-type: none"> - connect a number of NO devices in parallel without quantity limits; - several NC devices can be connected in series, with no limits as to quantity; - connect 2 devices with 8.2 kΩ constant resistance output in parallel. If there are more than 2 devices, they must be connected in a cascade with just one 8.2 kΩ termination resistance; - connect 2 NO and NC devices in parallel, placing a 8.2 kΩ resistance in series on the NC contact (this also allows for a combination of three devices NO - NC and 8.2 kΩ)
P.P.	input for devices which control Step-by-Step manoeuvres. NO contacts can be connected to this input
OPEN	input for devices which control only opening manoeuvre. NO contacts can be connected to this input
CLOSE	input for devices which control only closure manoeuvre. NO contacts can be connected to this input
ENC1	input encoder - gearmotor 1 (terminal 1, 2); it is not necessary to observe any polarity
ENC2	input encoder - gearmotor 2 (terminal 4, 5); it is not necessary to observe any polarity
M1	output for gearmotor 1 (terminal 7, 8, 9)
M2	output for gearmotor 2 (terminal 10, 11, 12)

[*] The outputs FLASH, ELS and S.C.A. can be programmed with other functions (see "TABLE 3 - Level 1 functions"; or via the Oview programmer; see paragraph 8.3).

4.1 - Electrical connections of gearmotor with control unit mod. HK7024

Caution! - Only make the electrical connections after installing the gearmotor.

WARNINGS

- Connections must be made exclusively by qualified personnel.
- All electrical connections must be made with the unit disconnected from the mains power supply and with the buffer battery disconnected (if present).
- The electrical power line must be fitted with a device that enables complete disconnection of the automation from the mains. The disconnection device must have a gap between contacts that ensures complete disconnection in the conditions of overvoltage category III, in compliance with installation regulations. If necessary, this device guarantees rapid and safe disconnection from the mains, and therefore should be located in view of the automation. However, if located in a concealed position, it must have a system that blocks against inadvertent or unauthorised reconnection to prevent all risks. The disconnection device is not supplied with the product.

01. Open the cover (fig. 14-1);
 02. Raise the control unit (fig. 14-2);
 03. Pass the power cable and other cables through one of the holes on the lower section of the gearmotor; strip the sheath on the cable (fig. 14-4);
 04. Unscrew the cable clamp and route the power cable as required (fig. 14-5);
 05. First connect the power cable, see fig. 14-6;
 06. Secure the power cable with the cable clamp (fig. 14-7);
 07. Then connect the electric cables of motors M1 and M2, observing the symbols on the label (fig. A):
 - a) connect the motor that activates the subordinate leaf (the second to start the opening manoeuvre) to terminal M1 (7-8-9) and then the respective encoder to terminals 1-2;
 - b) connect the motor that activates the main leaf (the first to start the opening manoeuvre) to terminal M2 (10-11-12) and then the respective encoder to terminals 4-5;
- IMPORTANT!** - If there is only one gearmotor in the system, connect it to terminal M2 leaving terminal M1 free;

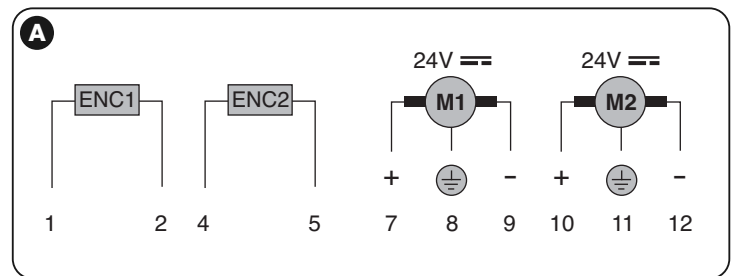

08. The connect the electric cables of the various devices present, with reference to fig. 17 and paragraph 4.3 **Note** - To facilitate cable connections, the terminals can be removed from their seats;
09. Close the cover of the gearmotor (fig. 14-8).

4.2 - Connection of gearmotor without control unit mod. HK7224

01. Open the cover as shown in fig. 15-1;
02. Pass the motor cable through one of the holes on the lower section of the gearmotor; strip the sheath on the cable (fig. 15-2);
03. Unscrew the cable clamp (fig. 15-3), place the cable in the relative route and connect the wires as shown in fig. 16-4; observe the symbols on the label ;
03. Secure the cable with the cable clamp (fig. 15-5);
04. Close the cover of the gearmotor (fig. 15-6).

4.3 - Connection of other devices

If further devices present in the system need to be powered, for example a transponder card reader or the key selector light, these devices can be connected to the control unit using terminals "P.P. (positive)" and "STOP (negative)" (fig. 13). The power supply voltage is 24 Vdc, -30% ÷ +50%, with maximum available current 200 mA.

Note - The voltage present on terminals "P.P." and "STOP" remains connected even when the "Stand By" function is activated on the card.

4.4 - Routing connected devices

To enable control unit recognition of the devices connected to the BlueBus system, they need to be routed. This operation must be performed by positioning the electric jumper correctly on each device: see fig. B.

To route other devices, consult the relative instruction manuals.

At the end of the installation procedure, or after removing photocells or other devices, the device learning procedure must be performed as described in paragraph 4.6.

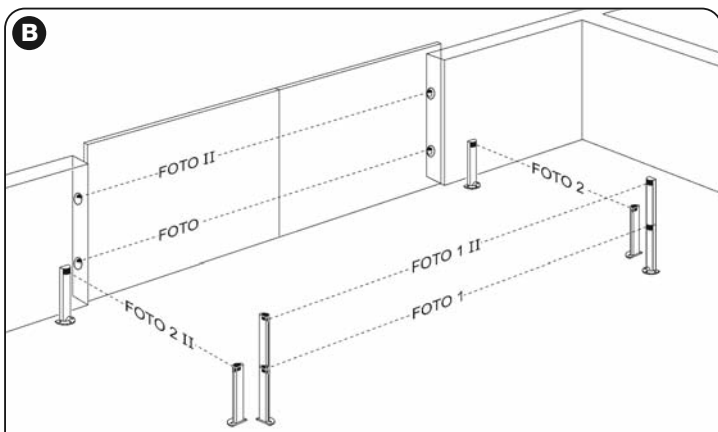
TABLE 2 - PHOTOCELL ADDRESSES

Photocell	Jumpers
FOTO External photocell h = 50 with trip on closure (stops and inverts movement)	
FOTO II External photocell h = 100 with trip on closure (stops and inverts movement)	
FOTO 1 Internal photocell h = 50 with trip on closure (stops and inverts movement) and opening (stops and restarts when photocell is disengaged)	
FOTO 1 II Internal photocell h = 100 with trip on closure (stops and inverts movement) and opening (stops and restarts when photocell is disengaged)	
FOTO 2 Internal photocell with trip on opening (stops and inverts movement)	
FOTO 2 II Internal photocell with trip on opening (stops and inverts movement)	
FOTO 3 CONFIGURATION NOT ADMITTED	

4.5 - Initial start-up and electrical connections

After powering up the control unit, perform the following checks:

- After a few seconds, make sure that the “Bluebus” LED (fig. 16) flashes regularly with a frequency of about one flash per second.
- Make sure that the LEDs on the photocells (fig. 16) flash (both on TX and RX). The type of flashing is not important during this stage.
- Make sure that the flashing light connected to the FLASH output is off.

If the above conditions are not satisfied, switch off the power supply to the control unit and check the electrical connections previously made.

4.6 - Learning of the devices connected

After the initial power-up, the control unit must be able to recognise the devices connected to the “Bluebus” and “Stop” inputs.

IMPORTANT! – The learning procedure must be performed even if no device is connected to the control unit.

The control unit is able to recognise the various connected devices individually through the self-learning procedure and detect possible faults. For this reason it is necessary to perform self-learning every time a new device is added or an existing device is removed.

To indicate when the self-learning procedure is required, LEDs L1 and L2 on the control unit (fig. 16) emit a number of slow flashes:

01. Press and hold down ◀ and “Set” keys at the same time (fig. 16).
02. Release the keys when LEDs L1 and L2 start flashing quickly (after approx. 3 seconds).
03. Wait a few seconds for the control unit to complete the device learning phase.
04. At the end of this phase, the “Stop” LED must be lit and LEDs “L1” and “L2” must be turned off (LEDs L3 and L4 may start flashing).

4.7 - Mechanical limiter position learning

After learning the connected devices (paragraph 4.6), the positions of the mechanical stops must also be learnt (maximum opening and maximum closing). There are three ways to perform this procedure: **automatic**, **manual** and **combined**.

In **automatic mode**, the control unit learns the positions of the mechanical stops and calculates the most suitable offset value for the leaves (SA and SC, fig. C).

In **manual mode**, the eight positions of the mechanical stops (fig. C) are programmed one by one, moving the leaf to the required points. The position to program is identifiable by the flashing status of one of the eight leds (L1-L8), see **Table 2**.

In **combined mode**, the automatic procedure can be performed and then, using the manual procedure, one or more positions may be modified, with the exception of positions “0” and “1” (fig. C) which coincide with the positions of the mechanical stops.

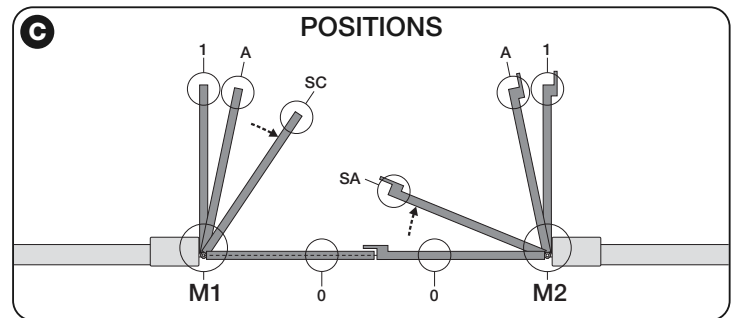
TABLE 2

Position	Led	Description
Position 0 (motor 1)	L1	Maximum closing position: when leaf 1 reaches closing mechanical stop
Position 0 (motor 2)	L2	Maximum closing position: when leaf 2 reaches closing mechanical stop
Position SA (motor 2)	L3	Opening offset: when leaf 2 passes this position the opening of leaf 1 begins
Position A (motor 1)	L4	Desired opening position: position at which the leaf connected to motor 1 must stop at the end of an opening manoeuvre. This position does not need to coincide with the opening mechanical stop but can be chosen as desired between the positions 0 and 1
Position A (motor 2)	L5	Desired opening position: position at which the leaf connected to motor 2 must stop at the end of an opening manoeuvre. This position does not need to coincide with the opening mechanical stop but can be chosen as desired between the positions 0 and 1
Position SC (motor 1)	L6	Closing offset: when leaf 1 reaches this position, leaf 2 begins to close
Position 1 (motor 1)	L7	Maximum opening position: when leaf 1 reaches the opening mechanical stop
Position 1 (motor 2)	L8	Maximum opening position: when leaf 2 reaches the opening mechanical stop

4.7.1 - Learning in automatic mode

01. Press and hold keys “Set” and “▶” at the same time.
02. Release the keys when leds “L3” and “L4” start flashing quickly (after approx. 3 seconds).
03. Ensure that the automation completes the following sequences of manoeuvres:
 - a - Low speed closure of gearmotor M1 through to the mechanical stop
 - b - Low speed closure of gearmotor M2 through to the mechanical stop
 - c - low speed opening of gearmotor M2 and gearmotor M1 through to the mechanical stop
 - d - High speed closure of gearmotors M1 and M2

Warnings:

- If the first manoeuvre (a) does not close the leaf controlled by motor M1 but closes the one controlled by M2, press key “◀” or “▶” to stop the learning phase. At this point, invert the connections of motors M1 and M2 on the terminals on the control unit and then those of the respective encoders; after this start the procedure from point 01;
- If the first two manoeuvres (a and b) are not “closing” but are “opening”, press key “◀” or “▶” to stop the learning phase. At this point, on the gearmotor that completed the opening manoeuvre, invert the polarity of the two wires of gearmotor M1 (terminals 7 and 9) and of M2 (terminals 10 and 12) and then start the procedure from point 01;
- 04. At the end of the Closing manoeuvre of the 2 motors (d), leds “L3” and “L4” turn off to indicate that the procedure has been completed correctly.

Warnings:

- During the automatic learning procedure, if a photocell trips or a device connected to the “stop” input is activated, the procedure is interrupted and led L1 starts flashing. To resume the learning process, the procedure must be started again from point 01;
- The automatic learning procedure can be repeated at any time, also after installation; for example following modifications to the position of the mechanical stops.

4.7.2 - Learning in manual mode

Caution! – From step 03 onwards:

- to move from led L1 to L8, briefly press key ◀ or ▶ (the led flashes to indicate the current position);
- to move the motor in one or the other direction, press and hold key ◀ or ▶.

- 01.** Press and hold keys “Set” and “▶” at the same time.
- 02.** Release the keys when led “L1” starts flashing (after approx. 1 second);
Note – After 3 seconds have elapsed, if the keys “Set” and “▶” are not released, the “automatic learning” procedure is started up, and not the manual procedure.
- 03.**
- **LED L1 flashes: position 0 of M1**
To bring motor 1 to **position 0 (fig. C)**: press and hold down the ◀ or ▶ keys. On reaching the position, release the key to stop the manoeuvre. To memorise the position, press and hold down the “Set” key for at least 3 seconds and then release it (after 2 seconds LED L1 remains on and on releasing the “Set” key LED L2 begins flashing).
 - **LED L2 flashes: position 0 of M2**
To bring motor 2 to **position 0 (fig. C)**: press and hold down the ◀ or ▶ keys. On reaching the position, release the key to stop the manoeuvre. To memorise the position, press and hold down the “Set” key for at least 3 seconds and then release it (after 2 seconds LED L2 remains on and on releasing the “Set” key LED L3 begins flashing).
 - **LED L3 flashes: position SA of M2**
To bring motor 2 to **position SA (fig. C)**: press and hold down the ◀ or ▶ keys. On reaching the position, release the key to stop the manoeuvre. To memorise the position, press and hold down the “Set” key for at least 3 seconds and then release it (after 2 seconds LED L3 remains on and on releasing the “Set” key LED L4 begins flashing).
 - **LED L4 flashes: position A of M1**
To bring motor 1 to **position A (fig. C)**: press and hold down the ◀ or ▶ keys. On reaching the position, release the key to stop the manoeuvre. To memorise the position, press and hold down the “Set” key for at least 3 seconds and then release it (after 2 seconds LED L4 remains on and on releasing the “Set” key LED L5 begins flashing).
 - **LED L5 flashes: position A of M2**
To bring motor 2 to **position A (fig. C)**: press and hold down the ◀ or ▶ keys. On reaching the position, release the key to stop the manoeuvre. To memorise the position, press and hold down the “Set” key for at least 3 seconds and then release it (after 2 seconds LED L5 remains on and on releasing the “Set” key LED L6 begins flashing).
 - **LED L6 flashes: position SC of M1**
To bring motor 1 to **position SA (fig. C)**: press and hold down the ◀ or ▶ keys. On reaching the position, release the key to stop the manoeuvre. To memorise the position, press and hold down the “Set” key for at least 3 seconds and then release it (after 2 seconds LED L6 remains on and on releasing the “Set” key LED L7 begins flashing).
 - **LED L7 flashes: position 1 of M1**
To bring motor 1 to **position 1 (fig. C)**: press and hold down the ◀ or ▶ keys. On reaching the position, release the key to stop the manoeuvre. To memorise the position, press and hold down the “Set” key for at least 3 seconds and then release it (after 2 seconds LED L7 remains on and on releasing the “Set” key LED L8 begins flashing).
 - **LED L8 flashes: position 1 of M2**
To bring motor 2 to **position 1 (fig. C)**: press and hold down the ◀ or ▶ keys. On reaching the position, release the key to stop the manoeuvre. To memorise the position, press and hold down the “Set” key for at least 3 seconds and then release it to exit programming (after 2 seconds LED L8 remains on until the “Set” key is released).

Note – To perform manual programming in a system with a single gearmotor, proceed as described in paragraph 4.7.2 and at **step 03** program positions “0” and then “1” of M1, ignoring the part related to keys “◀” and “▶”, and using the “Set” key only, as described. **Important! – In the manual procedure, positions “SA” of M2; “A” of M1; “SC” of M1 must not be programmed.**

4.7.3 - Learning in combined mode

This procedure after completing the automatic learning cycle:

- 01.** Press and hold keys “Set” and “▶” at the same time.
- 02.** Release the keys when led “L1” starts flashing (after approx. 1 second);
Note – After 3 seconds have elapsed, if the keys “Set” and “▶” are not released, the “automatic learning” procedure is started up, and not the manual procedure.
- 03.** Briefly press key “◀” or “▶” to move the flashing led (L1-L8) to the position to be programmed and proceed for each position, as described in step 03 of the manual learning procedure (paragraph 4.7.2).
Repeat this operation for all other positions to be modified.

To complete the manual learning process, press key “▶” repeatedly to move the led that flashing beyond position L8.

4.8 - Checking movement of gate leaves

At the end of the learning procedure, it is advisable to make the control unit perform a few opening and closing manoeuvres to ensure that the gate moves correctly and to check for installation or setting defects.

- 01.** Press the “Open” key. Check for the correct leaf opening offset and check that the opening manoeuvre includes the acceleration, constant speed and deceleration phases and that the leaf limit switch is set a few centimetres from the opening mechanical stops.
- 02.** Press the “Close” key and check that the closure manoeuvre includes the acceleration, constant speed and deceleration phases. Check that the leaf closure offset is correct. At the end of the manoeuvre, the leaves must be perfectly closed on the mechanical closure stop.

- 03.** Make sure that the flashing light flashes at intervals of 0.5 sec on, 0.5 sec off during manoeuvres.

5 TESTING AND COMMISSIONING

These are the most important phases in the installation of the automation system, in order to guarantee maximum system safety. Testing can also be used to check the devices in the automation system regularly. The automation system testing and commissioning phases must be carried out by qualified experts who must be responsible for determining the tests necessary to check the solutions adopted vis-à-vis the risks involved, and to check the observance of all legal and regulatory obligations: in particular all the requirements of the EN 12445 standard which sets forth the test methods for checking automated gates.

Additional devices must undergo specific testing, both in terms of functionality as well as their correct interaction with HYKE; please refer to the relevant individual instruction manuals.

5.1 - Testing

The sequence of steps to take to carry out testing refers to a typical system (fig. 3):

- 1** Ensure that everything stated in the “Installation warnings” chapter has been observed.
- 2** Release the gearmotors manually and check that when you operate the leaf, at the point designed especially for the manual manoeuvre, the leaves can either be opened or closed with a force of less than 390 N.
- 3** Secure the gearmotors (see chapter 3.6).
- 4** Using the control devices (transmitter, command button, key selector, etc.), perform some Gate Opening, Closing and Stop tests, making sure the movement of the leaves corresponds with each test. It is a good idea to carry out several tests in order to evaluate the movement of the leaves and pinpoint any assembly or adjustment defects as well as to check for any particular points of friction.
- 5** Check one by one that all the safety devices in the system work properly (photocells, sensitive edges, etc.). When a device is activated, the “BLUE-BUS” LED on the control unit emits two quicker flashes to confirm that recognition has taken place.
- 6** If the hazardous situations caused by the movement of the leaves have been safeguarded by limiting the force of impact, the force must be measured in accordance with the EN 12445 standard and, if necessary, if the control of the “gearmotor force” is used as an aid to the system to reduce the force of impact, try and then find the adjustment that achieves the best results.

5.2 - Commissioning

Commissioning can only take place once all the testing phases have been carried out successfully.

- 1** Put together the automation system’s technical file, which should include the following documents: an overall diagram of the automation system, the diagram of the electrical connections made, the current risk analysis and the related solutions adopted, the manufacturer’s declaration of conformity for all the devices used and the declaration of conformity filled in by the installer.
- 2** Affix a data plate onto the gate which specifies the following information, at least: the type of automation system, the name and address of the manufacturer (responsible for the commissioning), the serial number, the year of manufacture and the EC mark.
- 3** Fill in the declaration of conformity of the automation system and hand it over to its owner.
- 4** Fill in and hand over to the owner of the automation system the “User’s guide” of the automation system.
- 5** Fill in and hand over to the owner of the automation system the “Maintenance schedule” which contains instructions on the maintenance of all the devices in the automation system.
- 6** Before commissioning the automation system, inform the owner of all the hazards and residual risks entailed.

For all the documentation mentioned, the Nice technical support service provides the following: instruction manuals, guides and precompiled forms. Also visit: www.nice-service.com

6 PROGRAMMING THE CONTROL UNIT

The control unit has 3 keys **OPEN** (◀), **STOP (SET)**, **CLOSE** (▶) that can be used both for controlling the unit during testing and for programming the available functions.

The programmable functions available are divided into 2 levels and their relative operating status is displayed by means of the 8 LEDs (**L1**...**L8**) on the control unit (LED lit = function active; LED off = function not active).

Use the programming keys:

OPEN (◀): – key for controlling gate opening; – selection key during programming.

STOP/SET: key for stopping a manoeuvre; if pressed for more than 5 seconds,

it enables entry to programming mode.

CLOSE (▶): – key for controlling gate closure; – selection key during programming.

6.1 - Level one programming (ON-OFF functions)





All level 1 functions are set by default to “OFF” and may be modified at any time. To check the functions see **Table 3**. For the programming procedure see **Table 4**.

IMPORTANT – In the programming procedure, the maximum time interval that can elapse between activation of one key and the next is 10 seconds. When this time elapses, the procedure terminates automatically, memorising the modifications made up until then.

TABLE 3 - First level functions

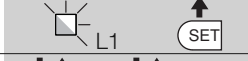
LED	Function	Description
L1	Automatic closure	<u>Function ACTIVE:</u> after an opening movement, there is a pause (equal to the programmed time) after which the control unit automatic initiates a closure movement. The factory setting for the Pause time is 30 sec. <u>Function NOT ACTIVE:</u> function is “semiautomatic” type.
L2	Reclose after photo	<u>Function ACTIVE:</u> if the photocells are activated during the opening or closing manoeuvre, the pause time is reduced to 5 seconds regardless of the programmed pause time. With “automatic closure” disabled, if the photocells are activated during closure the “automatic closure” is activated with the programmed “pause time”.
L3	Always close	<u>Function ACTIVE:</u> in the event of a power failure, even of short duration, when power is restored the control unit detects gate open and automatically starts a closure manoeuvre, preceded by 5 seconds of pre-flashing. <u>Function NOT ACTIVE:</u> when power is restored the gate remains where it is.
L4	All standby	<u>Function ACTIVE:</u> after 1 minute from the end of the manoeuvre, the control unit turns off the “BlueBus” output (connected devices), Bus T4 (connected devices), the outputs flash, ELS and sca, some internal circuits and all leds with the exception of the BlueBus led, which flashes at a slower interval. When the control unit receives a command, it resumes normal operation (after a short delay). This function is used to reduce consumption, an important aspect in the case of battery powered devices or when using photovoltaic panels.
L5	lock/Courtesy light	<u>Function ACTIVE:</u> the “electric lock” output switches its operation to “courtesy light”. <u>Function NOT ACTIVE:</u> the output operates as an electric lock.
L6	Pre-flash	<u>Function ACTIVE:</u> a 3 second pause can be added between the flashing light signal and the start of the manoeuvre to provide advance warning of a hazard situation. <u>Function NOT ACTIVE:</u> flashing light signal coincides with the start of the manoeuvre.
L7	“Close” becomes “Partial open 1”	<u>Function ACTIVE:</u> all the commands corresponding to “Close” (“Close” input or “Close” radio control) are replaced by the “Partial open 1” command.
L8	“Gate open light” or “Maintenance light”	<u>Function ACTIVE:</u> the “gate open light” output on the control unit switches to the “maintenance light” function. <u>Function NOT ACTIVE:</u> the output operates as “gate open light”.

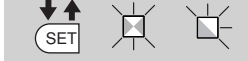
TABLE 4 - Programming procedure (first level functions)

01. Press and hold down the “Set” key for approx. 3 seconds;	
02. Release the key when LED “L1” starts flashing;	
03. Press the “◀” or “▶” key to move the flashing LED to the LED representing the function to be modified;	
04. Press “Set” to change the status of the function: (short flash = OFF; long flash = ON);	
05. Wait 10 seconds (maximum time) to exit the programming mode.	

Note – During this procedure, points 03 and 04 need to be repeated when programming other functions to “ON” or “OFF” during the phase itself.

6.2 - Level two programming (adjustable parameters)

All level 2 functions are set by default as highlighted in grey in Table 5, and may be modified at any time as explained in Table 6.

The parameters can be set on a scale from 1 to 8. To check the value corre-

sponding to each LED see Table 8. **IMPORTANT** – In the programming procedure, the maximum time interval that can elapse between activation of one key and the next is 10 seconds. When this time elapses, the procedure terminates automatically, memorising the modifications made up until then.o.













TABLE 5 - Second level functions

Input LED	Parameter	LED (level)	Value	Description
L1	Pause time	L1	5 seconds	Sets the pause time, namely the time which lapses before automatic closure. This will only take effect if closing is active.
		L2	15 seconds	
		L3	30 seconds	
		L4	45 seconds	
		L5	60 seconds	
		L6	80 seconds	
		L7	120 seconds	
		L8	180 seconds	
L2	Step by step function	L1	Open – stop – close – stop	Sets the sequence of commands associated with the “Step-by-Step”, “Open”, or “Close” inputs or the radio control. Note – When setting L4 , L5 , L7 and L8 , the behaviour of the “Open” and “Close” commands is also modified.
		L2	Open – stop – close – open	
		L3	Open – close – open – close	
		L4	Apartment block: • In the opening manoeuvre the “Step by Step” and “Open” commands have no effect; the “Close” command causes the movement to be inverted, i.e. the closure of the leaf. • In the closure manoeuvre the “Step by Step” and “Open” commands cause the movement to be inverted, i.e. the leaf to open; the “Close” command has no effect.	
		L5	Apartment block 2: • In the opening manoeuvre the “Step by Step” and “Open” commands have no effect; the “Close” command causes the movement to be inverted, i.e. the closure of the leaf. If the transmitted command persists for more than 2 seconds, a “Stop” is performed. • In the closure manoeuvre the “Step by Step” and “Open” commands cause the movement to be inverted, i.e. the leaf to open; the “Close” command has no effect. If the transmitted command persists for more than 2 seconds, a “Stop” is performed.	
		L6	Step-by-step 2 (less than 2 sec. generates partial opening).	
		L7	Hold-to-run: the manoeuvre is performed only if the transmitted command persists; if the command is interrupted the manoeuvre stops.	
		L8	Opening in semi-automatic mode, closing in hold-to-run mode.	
L3	Motor speed	L1	Very slow	Sets the motor speed during normal travel.
		L2	Slow	
		L3	Medium	
		L4	Fast	
		L5	Very fast	
		L6	Extremely fast	
		L7	Fast opening, Slow Closing	
		L8	Extremely fast Opening, Medium Closing	
L4	Motor discharge after closing	L1	No discharge	Sets duration of “short inversion” of both motors after performing Close manoeuvre with the aim of reducing the final residual thrust.
		L2	Level 1 - Minimum discharge (about 100 ms)	
		L3	Level 2 - ...	
		L4	Level 3 - ...	
		L5	Level 4 - ...	
		L6	Level 5 - ...	
		L7	Level 6 - ...	
		L8	Level 7 - Maximum discharge (about 800 ms)	
L5	Motor force	L1	Level 1 - Minimum Force	Adjusts the force of both motors
		L2	Level 2 - ...	
		L3	Level 3 - ...	
		L4	Level 4 - ...	
		L5	Level 5 - ...	
		L6	Level 6 - ...	
		L7	Level 7 - ...	
		L8	Level 8 - Maximum Force	
L6	Pedestrian or partial opening	L1	Pedestrian 1 (opening of leaf M2 to 1/4 of total opening)	Sets type of opening associated with “Partial open 1” command. In levels L5, L6, L7, L8; “minimum” opening means the smaller opening out of M1 and M2; for example, if M1 opens to 90° and M2 opens to 110°, the minimum opening is 90°
		L2	Pedestrian 1 (opening of leaf M2 to 1/2 of total opening)	
		L3	Pedestrian 3 (opening of leaf M2 to 3/4 of total opening)	
		L4	Pedestrian 4 (Complete opening of leaf 2)	
		L5	Partial 1 (opening of two leafs to 1/4 of “minimum” opening)	
		L6	Partial 2 (opening of two leafs to 1/2 of “minimum” opening)	
		L7	Partial 3 (opening of two leafs to 3/4 of “minimum” opening)	
		L8	Partial 4 (opening of two leafs to “minimum” opening)	

L7	Maintenance warning	L1	500	Controls the number of manoeuvres: when this number is exceeded, the control unit signals an automation maintenance request; see paragraph 6.3.2. – Maintenance warning.
		L2	1000	
		L3	1500	
		L4	2500	
		L5	5000	
		L6	10000	
		L7	15000	
		L8	20000	
L8	List of faults	L1	Manoeuvre 1 result (most recent)	The type of fault that has occurred in the last 8 manoeuvres can be established See TABLE 10 – Fault log.
		L2	Manoeuvre 2 result	
		L3	Manoeuvre 3 result	
		L4	Manoeuvre 4 result	
		L5	Manoeuvre 5 result	
		L6	Manoeuvre 6 result	
		L7	Manoeuvre 7 result	
		L8	Manoeuvre 8 result	

Note – The factory settings are highlighted in grey.

TABLE 6 - Programming procedure (second level functions)

01. Press and hold down the “Set” key for approx. 3 seconds.;	 3 s
02. Release the key when LED “L1” starts flashing;	 L1 
03. Press the “◀” or “▶” key to move the flashing LED to the LED representing the “input LED” of the parameter to be modified;	 or  
04. Press and hold the “Set” key through to completion of point 06;	
05. Wait approx. 3 seconds, until the LED representing the current level of the parameter to be modified illuminates;	
06. Press keys “◀” or “▶” to move the LED representing the value of the parameter;	 or  
07. Release the “Set” key;	
08. Wait 10 seconds (maximum time) to exit the programming mode.	 10 s

Note – During this procedure, points 03 to 07 need to be repeated when programming other parameters during the phase itself.

6.3 - Special functions

6.3.1 - Function: “Move anyway”

This function allows the automation to be operated even when any of the safety devices does not work correctly or is out of use. The automation can be controlled in the “hold-to-run” mode. Proceed as follows:

- 01.** Send a command to operate the gate using a transmitter or a key selector, etc. If everything operates correctly, the gate will move normally, otherwise proceed as follows;
- 02.** within 3 seconds, activate the control again and keep it activated;
- 03.** after approximately 2 seconds, the gate will perform the required movement in “hold-to-run” mode; i.e. the gate will continue to move only as long as the control is activated.

If the safety devices do not operate, the flashing light flashes a few times to indicate the kind of problem (see chapter 6 - Table 8).

6.3.2 - Function: “Maintenance warning”

This function serves to indicate when the automation requires maintenance. The maintenance warning signal is given by way of a lamp connected to the S.C.A. (open gate light) output when this output is programmed as “Maintenance light”. The various warning lamp signals are shown in Table 7.

To program the limit value of the maintenance operations, see Table 5.

Table 7 - “Maintenance light”

Number of manoeuvres	Signal
Below 80% of the limit	Light on for 2 seconds at the start of the opening manoeuvre.
Between 81% and 100% of the limit	Light flashing for the entire duration of the manoeuvre.
Beyond 100% of the limit	Light flashing continuously.

6.4 - Deleting the memory

To delete the control unit memory and restore all factory settings, proceed as follows:

press and hold keys “◀” and “▶” until leds L1 and L2 start flashing.

7 WHAT TO DO IF... (troubleshooting guide)

Some devices are able to emit signals that serve to recognise their state of operation or possible faults.

If a flashing light is connected to the FLASH output on the control unit, it will flash at intervals of 1 second during a manoeuvre. If faults occur, the flashing light will emit a sequence of two shorter flashes separated by a 1 second pause. Table 8 shows the cause and solution for each type of signal.

The LEDs on the control unit also emit signals.

Table 9 shows the cause and solution for each type of signal.

It is possible to verify faults that have occurred during the last 8 manoeuvres. See Table 10.

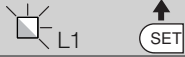





TABLE 8 - Flashing light signals (FLASH)

Flashes	Problem	Solution
1 short flash 1 second pause 1 short flash	Bluebus system error	At the start of the manoeuvre, the devices connected to Bluebus do not correspond to those recognized during the self-learning phase. One or more devices may be disconnected or faulty; check and, if necessary, replace them. In case of modifications repeat the device self-learning process (see paragraph 4.6).
2 short flashes 1 second pause 2 short flashes	Photocell activated	One or more photocells do not enable movement or have caused a movement inversion during travel; check to see if there are any obstructions.
3 short flashes 1 second pause 3 short flashes	Function activation "Obstacle detection" by force limiter	During the movement, the motors encountered excessive resistance; identify the cause and if necessary increase the level of force of the motors.
4 short flashes 1 second pause 4 short flashes	STOP input activation	At the start of the manoeuvre or during the movement, the STOP input was activated; identify the cause.
5 short flashes 1 second pause 5 short flashes	Error on internal parameters in control unit	Wait at least 30 seconds, then try giving a command and if necessary turn off the power supply. If the condition persists, there may be a malfunction and the electronic board must be replaced.
6 short flashes 1 second pause 6 short flashes	Maximum limit of consecutive manoeuvres or manoeuvres per hour exceeded.	Wait a few minutes until the manoeuvre limiting device falls to below the maximum limit.
7 short flashes 1 second pause 7 short flashes	Electric circuits fault	Wait at least 30 seconds, then try sending a command and if necessary turn off the power supply. If the condition persists, there may be a malfunction and the electronic board must be replaced.
8 short flashes 1 second pause 8 short flashes	A command is already present that disables execution of other commands	Check the type of command that is always present; for example, it could be a command from a timer on the "open" input.
9 short flashes 1 second pause 9 short flashes	The automation has been blocked by a "Block automation" command	Release the automation by giving the "Automation release" command.
10 short flashes 1 second pause 10 short flashes	"Obstacle detection" by encoder function activated	During the movement, the motors have been blocked by higher friction; identify the cause.

TABLE 9 - Signals given by LEDs on control unit (fig. 16)

LED	Problem	Solution
BLUEBUS Always off	Fault	Check that the control unit is powered. Check that the fuses have not blown: if they have, check the cause of the fault and replace with others with the same value
Always on	Serious fault	A serious fault has occurred: try disconnecting electrical power from the control unit. If the problem persists it will be necessary to replace the electronic board
1 flash per second	Everything normal	Control unit works correctly
2 quick flashes	Input status variation	Normal if one of the inputs (PP, STOP, OPEN, CLOSE) changes: photocells activated or a command given via a transmitter
Series of flashes separated by one second pause	Various	Refer to Table 8
STOP Always off	Activation of the devices connected to the STOP input	Check the devices connected to the STOP input
Always on	Everything normal	STOP input active
S.S. Always off	Everything normal	S.S. input not active
Always on	S.S. input activation	Normal if the device connected to the S.S. input is active
OPEN Always off	Everything normal	OPEN input not active
Always on	OPEN input activation	Normal if the device connected to the OPEN input is active
CLOSE Always off	Everything normal	CLOSE input not active
Always on	CLOSE input activation	Normal if the device connected to the CLOSE input is active
L1 - L2 Slow flashing	Change in number of devices connected to Bluebus or device self-learning not performed	The device self-learning process must be performed (see paragraph 4.6)
L3 - L4 Slow flashing	Change in self-learning of the motor types or the positions of the mechanical stops	Self-learning of the mechanical stop positions has not been performed (see paragraph 4.7)

TABLE 10 - Fault log

01. Press and hold down the “Set” key for approx. 3 seconds;	
02. Release the key when LED “L1” starts flashing;	
03. Press keys “◀” or “▶” to move from the flashing LED to L8 LED (“input LED”) for the “Fault log” parameter;	
04. Press and hold the “Set” key through to completion of point 06;	
05. Wait approx. 3 seconds until the LEDs representing the levels corresponding to the manoeuvres with faults illuminate. The LED L1 indicates the result of the most recent manoeuvre while L8 indicates the eighth-to-last manoeuvre. If the LED is on this means that a fault has occurred; if the LED is off, everything is normal;	
06. Press keys “◀” and “▶” to select the required manoeuvre: the corresponding LED performs a number of flashes equal to those normally performed by the flashing light;	
07. Release the “Set” key.	

8 FURTHER DETAILS

The following accessories are envisaged for HYKE (optional): receivers in the family SMXI, OXI, the programmer Oview, the solar power panel Solemyo and buffer battery mod. PS124.

8.1 - Connecting a radio receiver

The control unit has a connector for connecting radio receivers (optional accessories) belonging to the SMXI and OXI families. To connect a receiver, disconnect power from the control unit and proceed as shown in **fig. fig. 17. Table 11** and **Table 12** show the commands corresponding to the outputs on the control unit.

Table 11

SMXI / SMXIS or OXI / OXIFM / OXIT / OXITFM in mode I or Mode II

Output no. 1	“S.S.” (Step by Step) command
Output no. 2	“Partial opening 1” command
Output no. 3	“Open” command
Output no. 4	“Close” command

Table 12

OXI / OXIFM / OXIT / OXITFM in extended mode II

No.	Command	Description
1	Step by step	“S.S.” (Step by Step) command
2	Partial opening 1	“Partial opening 1” command
3	Open	“Open” command
4	Close	“Close” command
5	Stop	Stops manoeuvre
6	Apartment block Step by Step	Apartment block control
7	Step by Step high priority	Gives command even when automation is blocked or commands are in progress
8	Partial open 2	Partial open (Opening of leaf M2 to 1/2 of normal opening)
9	Partial open 3	Partial open (Opening of two leafs to 1/2 of normal opening)
10	Open and block automation	It causes an opening manoeuvre, after which the automation is blocked; the control unit accepts no further commands with the exception of “Step by step high priority”, “Release” automation and (from Oview only) the commands “Release and close” and “Release and open”
11	Close and block automation	It causes a closure manoeuvre, after which the automation is blocked; the control unit accepts no further commands with the exception of “Step by step high priority”, “Release” automation and (from Oview only) the commands “Release and close” and “Release and open”
12	Block automation	It causes the manoeuvre to stop and the automation to block; the control unit accepts no further commands with the exception of “Step by step high priority”, “Release” automation and (from Oview only) the commands “Release and close” and “Release and open”.
13	Release automation	It causes the automation to be released and normal operation to resume

No.	Command	Description
14	Courtesy light timer on	The Courtesy light comes on with timed turning off
15	Courtesy light on-off	The Courtesy light turns on and off in step-by-step mode

8.2 - Connection and installation of the back-up battery mod. PS124

IMPORTANT! - The battery must only be connected to the control unit after all the phases of installation and programming have been completed, as the battery constitutes a source of emergency power.

To arrange connection to the Solemyo system, follow the stages of assembly **fig. 18**.

8.3 - Connection of the Oview programmer

The control unit has a BusT4 connector to which the Oview programming unit can be connect, and which allows the complete rapid management of the installation and maintenance phase as well as the diagnosis of the entire automation system. To access this connector, proceed as shown in **fig. 19** and connect the connector to the dedicated seat. The Oview can be connected to several Control units simultaneously (up to 5 without any particular precautions, and up to 60 observing the dedicated warnings) and can stay connected to the control unit even during the normal operation of the automation system. In this case, it can be used to send the commands directly to the control unit using the specific “user” menu. The Firmware upgrade can also be carried out. If there is a radio receiver from the OXI family in the control unit, Oview can be used to gain access to the parameters of the transmitters stored in the receiver itself. For further information, please consult the relevant instruction manual and the manual for the “Opera system book” system.

8.4 - Connecting the solar power system Solemyo

CAUTION! – When the automation is powered by the “Solemyo” system, IT MUST NEVER BE POWERED simultaneously by the electrical mains.

For more information on the Solemyo system, refer to the relative instruction manual.

To connect the Solemyo system, proceed as shown in **fig. 20**

8.5 - Connecting the external release system Kio

CAUTION! – Kio must be connected to the gearmotor controlling the leaf that moves first (starting from the gate closed position).

- 01.** Open the cover of the gearmotor (**fig. 21-1**).
- 02.** Remove the plastic guard of the gearmotor as shown in **fig. 21-2**;
- 03.** Insert the screw with nut in the hole as shown in **fig. 21-3**;
- 04.** Attach the two ends of the spring as shown in **fig. 22-4**;
- 05.** Insert the steel cable before the screw and then in the hole of the pin as shown in **fig. 21-5**;
- 06.** Secure the cable by tightening the relative screw (**fig. 21-5**);
- 07.** Route the other end of the cable through one of the holes on the lower section of the gearmotor as shown in **fig. 21-6**;
- 08.** Refit the plastic guard and then the cover of the gearmotor (**fig. 21-7**);
- 09.** At this point, connect the cable to Kio, with reference to the relative instruction manual.

In order to keep the safety level constant and to guarantee the maximum life span of the entire automation system, regular maintenance is vital. All maintenance work must be carried out in compliance with the safety provisions of this manual and in accordance with existing laws and regulations.

The product requires frequent inspection to check for imbalances of the doors or signs of wear or damage to the cables. Do not use the product if adjustments or repairs are required.

Important – During the product maintenance or cleaning operations, cut off the electricity supply to the control unit and any batteries envisaged.

For the other devices in the system, follow the instructions provided in their respective maintenance schedules.

For gearmotors HK7024, HK7224, scheduled maintenance is required at the latest 6 months or 20,000 manoeuvres after the previous maintenance work.

Maintenance can be performed as follows:

01. Cut off any electrical power source, including any back-up batteries;
02. Check the condition and wear of brackets and fixing plugs, paying special attention to erosion or rusting; replace all parts which do not provide sufficient guarantees;
03. Perform a trial release to ensure it is working properly – see paragraph 3.6.
04. Reconnect the electrical power sources and perform all the checks envisaged in chapter 5 - Testing.

DISPOSING OF THE PRODUCT

This product is an integral part of the automation system, and should therefore be disposed of together with it.

As for the installation operations, even at the end of this product's life span, the dismantling operations must be carried out by qualified experts.

This product is made up of various types of materials: some can be recycled while others need to be disposed of. Find out about the recycling or disposal systems envisaged by your local regulations for this product category.

Important! – Parts of the product could contain pollutants or hazardous substances which, if released into the environment, could cause harmful effects to the environment itself as well as to human health.

As indicated by the symbol opposite, throwing away this product as domestic waste is strictly forbidden. So dispose of it as differentiated waste, in accordance with your local regulations, or return the product to the retailer when you purchase a new equivalent product.



Important! – the local applicable regulations may envisage heavy sanctions in the event of illegal disposal of this product.

Disposal of the back-up battery (where present)

Important! – The flat battery contains pollutants and should therefore not be thrown away as common waste.

It should be disposed of as differentiated waste, as envisaged by your local applicable regulations.

Product lifetime

The lifetime is the average economic duration of the product. The value of lifetime is strongly influenced by the intensity of the manoeuvres performed by the automation. i.e. the sum of all factors that contribute to product wear (see Table 13).

To establish the probable lifetime of your automation, proceed as follows:

01. Calculate the severity index by adding all percentages of the items specified in Table 13;
02. In Graph 3 from the value obtained above, trace vertical line until it intersects the curve; from this point trace a horizontal line until it intersects the line of the "manoeuvre cycles". The value obtained is the estimated lifetime of your product.

The estimation of lifetime is made on the basis of design calculations and the results of tests performed on prototypes. As it is only an estimation, it does not represent any form of guarantee on the effective lifetime of the product.

Example of calculating the lifetime of a HYKE gearmotor with LONG length arm (refer to Table 13 and Graph 3):

- leaf length = 2,8 m (severity index: 20%); - leaf weight: 230 Kg m (severity index: 20%); - solid leaf (severity index: 15%); Total severity index = 55%; Estimated lifetime = 220.000 manoeuvre cycles

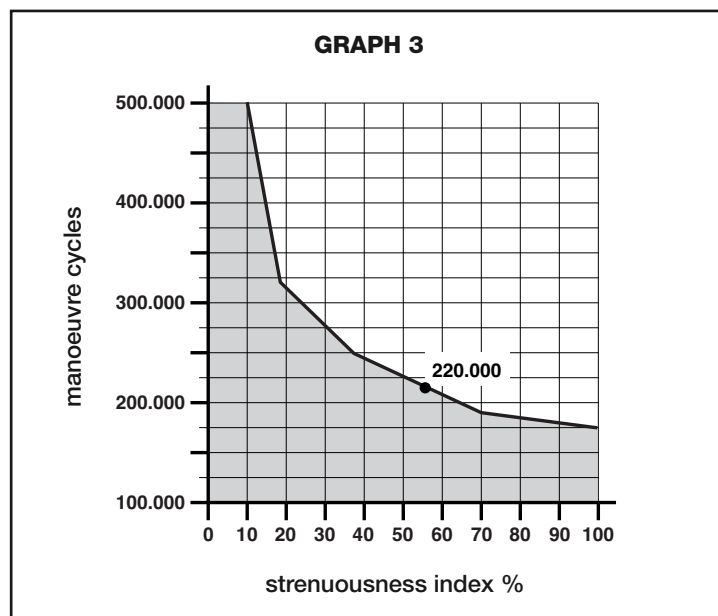

TABLE 13

		Severity index	
		LONG length arm	SHORT length arm
Leaf length	< 1,8	0%	15%
	1,8 - 2,5 m	15%	20%
	2,5 - 3 m	20%	30%
	3 - 3,5 m	30%	-
Leaf weight	< 200 kg	0%	30%
	200 + 250 kg	20%	40%
	> 250 kg	30%	-
Ambient temperature above 40°C or below 0°C or humidity over 80%		20%	20%
Solid leaf		15%	20%
Installation in windy zone		15%	20%

Note – The data refer to a balanced sectional door in perfect maintenance conditions

TECHNICAL SPECIFICATIONS OF PRODUCT

WARNINGS: • All technical specifications stated in this section refer to an ambient temperature of 20°C (± 5°C). • Nice S.p.a. reserves the right to apply modifications to products at any time when deemed necessary, maintaining the same intended use and functionality.

	HK7024K	HK7224K
Type	Electromechanical gearmotor for automations of gates and automatic doors with DC motor, epicyclical gear reducer and mechanical release. Built-in control unit and OXI radio receiver.	Electromechanical gearmotor for automations of gates and automatic doors with DC motor, epicyclical gear reducer and mechanical release.
Maximum torque	500 Nm	
Nominal torque	120 Nm	
Speed under no load	2.25 RPM	
Speed at nominal torque	2.00 RPM	
Maximum cycle frequency	40 cycles/hour	
Maximum continuous cycle time	approx. 7 minutes	
Application limits	the product can be used on gates with leaf weights up to 330 kg for lengths up to 1.8m or 200 kg for lengths up to 3.5m (see graph 1)	
Lifetime	estimated between 150,000 cycles and 500,000 cycles, according to the conditions stated in table 13 and graph 3	
Power supply	230 Vac (120 Vac for version HK7024K/V1) ±10%; 50/60 Hz	24 Vdc (±10%)
Backup power supply	Provision for buffer battery PS124	
Solar power	provision for SYKCE kit	
Maximum absorbed power	300 W	140 W
Maximum absorbed current	1,5 A (3 A for version HK7024K/V1)	6 A for a maximum interval of 2 s
Absorbed power with "All – Standby (1)" function when powered by PS124 or SYKCE kit (including OXI receiver)	less than 100 mW	
Flashing light output [*]	one LUCYB flashing light (12 V, 21 W bulb)	
Electric lock output [*]	one 12 Vac electric lock (max 15 VA)	
Gate open indicator output [*]	one 24 V lamp (max. 4 W) (the output voltage may vary between -30 and +50%, the output can also control small relays)	
BLUEBUS output	one output with load of maximum 15 Bluebus units (max. 6 pairs of MOFB or MOFOB photocells plus 2 pairs of MOFB or MOFOB photocells routed as opening devices plus max. 4 MOMB or MOTB control devices)	
STOP input	for normally closed contacts, normally open contacts or contacts with constant 8,2 kΩ resistance; selection of the type of contact is in self-learning mode and a modification with respect to the memorised status will generate a "STOP"	
SS input	for normally open contacts (closure of the contact generates a Step Step command)	
Radio engage	SM connector for receivers in the families SMXI, OXI and OXIFM	
Radio AERIAL input	50 Ω for cable type RG58 or similar	
Programmable functions	8 ON-OFF type functions (Table 3) and 8 settable functions (Table 5)	
Functions in self-learning	<ul style="list-style-type: none"> • Self-learning of devices connected to the BlueBus output. • Self-learning of the type of device connected to the "STOP" terminal (NO, NC contact or 8,2 kΩ resistance). <ul style="list-style-type: none"> • Self-learning of the gate leaf travel and automatic calculation of deceleration points and partial opening. • Self-learning of operation with one or two motors 	
Assembly	Vertical, with dedicated fixing plate	
Operating temperature	from -20°C to +50°C (at low temperatures, gearmotor efficiency is reduced)	
Use in acid, saline or potentially explosive atmospheres	NO	
Protection rating	IP 54 (with container intact)	
Dimensions (mm)	210 x 290 x 320 h	
Weight (kg)	10.5 Kg;	9.5 Kg

Notes:

(1) - Function can be activated with Oview programmer.

[*] - The outputs Flashing Light, Electric lock and Gate Open Indicator can be programmed with other functions (see "TABLE 3 – Level 1 functions"; or via the Oview programmer; see chapter 8.3). The electrical specifications of the output are adapted to the type of selected function: • flashing light function: lamp 12 Vdc, max. 21 W; • electric lock function: 12 Vac max. 15 VA; • other outputs (all types): 1 lamp or relay 24Vdc (-30 to +50%), max. 4 W.

CE DECLARATION OF CONFORMITY and declaration of incorporation of “quasi machine”

Declaration in accordance with the Directives: 2006/95/EC (LVD); 2004/108/CE (EMC); 2006/42/EC (MD) appendix II, part B

Note - The contents of this declaration correspond to declarations in the official document deposited at the registered offices of Nice S.p.a. and in particular to the last revision available before printing this manual. The text herein has been re-edited for editorial purposes. A copy of the original declaration can be requested from Nice S.p.a. (TV) I.

Declaration number: 334/HYKE

Revision: 0

Language: EN

Manufacturer's Name: NICE s.p.a.
Address: Via Pezza Alta 13, Z.I. Rustignè, 31046 Oderzo (TV) Italy
Person authorised to draw up technical documentation: Sig. Oscar Marchetto
Type of product: “HYKE” electromechanical gearmotor with built-in control unit
Model / Type: HK7024K, HK7224K
Accessories: SMXI, OXI, PS124, Oview

The undersigned, Luigi Paro, in the role of Managing Director, declares under his sole responsibility, that the product specified above conforms to the provisions of the following directives:

- Directive 2006/95/EC OF THE EUROPEAN PARLIAMENT AND COUNCIL of 12 December 2006 regarding the approximation of member state legislation related to electrical material destined for use within specific voltage limits, according to the following harmonised standards: EN 60335-1:2002 + A1:2004 + A11:2004 + A12:2006 + A2:2006 + A13:2008; EN 60335-2-103:2003
- DIRECTIVE 2004/108/EC OF THE EUROPEAN PARLIAMENT AND COUNCIL of 15 December 2004 regarding the approximation of member state legislation related to electromagnetic compatibility, repealing directive 89/336/EEC, according to the following standards: EN 61000-6-2:2005, EN 61000-6-3:2007

The product also complies with the following directives according to the requirements envisaged for “quasi machinery”:

- Directive 2006/42/EC OF THE EUROPEAN PARLIAMENT AND COUNCIL of 17 May 2006 related to machinery, and which amends the directive 95/16/EC (recast).
 - It is hereby declared that the pertinent technical documentation has been compiled in compliance with appendix VII B of directive 2006/42/EC and that the following essential requirements have been observed: 1.1.1- 1.1.2- 1.1.3- 1.1.5- 1.2.1-1.2.6- 1.3.1- 1.3.2- 1.3.3- 1.3.4- 1.3.7-1.3.9- 1.5.1- 1.5.2- 1.5.4- 1.5.5- 1.5.6- 1.5.7- 1.5.8- 1.5.10- 1.5.11- 1.5.13-1.6.1- 1.6.2-1.6.4- 1.7.2- 1.7.3- 1.7.4- 1.7.4.1- 1.7.4.2- 1.7.4.3
 - The manufacturer undertakes to transmit to the national authorities, in response to a motivated request, all information regarding the “quasi-machine”, while maintaining full rights to the related intellectual property.
 - Should the “quasi machine” be put into service in a European country with an official language other than that used in this declaration, the importer is obliged to arrange for the relative translation to accompany this declaration.
 - The “quasi-machine” must not be used until the final machine in which it is incorporated is in turn declared as compliant, if applicable, with the provisions of directive 2006/42/EC.

The product also complies, within the constraints of applicable parts, with the following standards:
 EN 13241-1:2003, EN 12445:2002, EN 12453:2002, EN 12978:2003

Oderzo, 15.01.10

Luigi Paro (Managing Director)



EN - Technical documentation
Images

IT - Documentazione Tecnica
Immagini

FR - Documentation Technique
Images

ES - Documentación Técnica
Imágenes

DE - echnische Dokumentation
Bilder

PL - Dokumentacja Techniczna
Zdjęcia

NL - Technische documentatie
Afbeeldingen

Instructions and warnings for the user

Before using the automation system for the first time, allow the installer to explain the origin of the residual risks and take a few minutes to read this instruction manual and the warnings for the user which the installer has handed you. Keep this manual in a safe place for future reference and hand it over to any new owner of the automation system.

IMPORTANT! – Your automation system is a machine which performs the commands you send it; improper and careless use could make it become dangerous:

- Do not operate the movement of the automation system if people, animals or objects lie in its range of action.
- It is strictly forbidden to touch parts of the automation system while the gate or door are in motion!
- The photocells are not a safety device but one that is auxiliary to safety. They are built with high reliability technology but they may, under extreme circumstances, malfunction or indeed fail and, in some cases, the failure may not immediately be visible. For these reasons, please observe the following warnings when using the automation system:
 - Transit is only permitted if the gate or door is completely open and with the leaves at a standstill
 - IT IS STRICTLY FORBIDDEN to transit while the gate or door is closing!
 - Ensure the photocells are working properly on a regular basis.

• **Children:** an automation system guarantees a high level of safety; indeed, thanks to its detection systems, it controls and guarantees movement in the presence of people or objects. It is however prudent to forbid children from touching or playing near the automation system and not to leave remote controls within their reach to avoid involuntary activation: **it is not a game!**

• The product is not intended for use by persons, including children, with limited physical, sensory or mental capacities, or who lack experience or knowledge, unless supervised or trained in the use of the product by a person responsible for their safety.

• **Faults:** if an operating fault is detected in the automation system, cut off the electricity supply to the automation system and release the gearmotor manually (see respective instruction manual) to operate the gate manually. Do not perform any repair work but contact your regular installer for assistance.

• **Do not change the system or the programming and adjustment parameters of the control unit: this lies within the area of responsibility of your installer.**

• **Breakage or lack of power supply:** while waiting for your installer to call by or for the power supply to be re-established, if the system is not equipped with a back-up battery, the automation system can still be used: simply perform the manual release of the gearmotor (see the respective instruction manual) and move the gate leaf manually as required.

• **Safety devices out of order:** the automation system can still work when a safety device doesn't work properly or is out of order. The gate can be controlled in "push to run" mode as follows:

- 01.** Send a command to operate the gate, using a transmitter or key selector, etc. If everything is working properly, the gate will move normally, otherwise proceed as follows:
- 02.** Within 3 seconds, send the command again and keep it activated;
- 03.** After approximately 2 seconds, the gate will perform the manoeuvre requested in "push to run" mode; i.e. the gate will continue to move only for as long as the command is activated.

N.B.! – If the safety devices are out of order, we recommend you have them repaired as soon as possible by qualified experts.

• The testing, routine maintenance and any repair work must be documented by the person who carries out the work; the documents must be kept by the owner of the system. The only operations that the user can perform regularly are the cleaning of the glass covers of the photocells (use a slightly damp soft cloth) and the removal of any leaves or pebbles which could hamper the automation system. **Important** – Before going ahead, to prevent someone from being able to activate the gate inadvertently, release the gearmotor manually (see the respective instruction manual).

• **Maintenance:** in order to keep the safety level constant and to guarantee the maximum life span of the entire automation system, regular maintenance (at least every 6 months) is vital. **All control, maintenance or repair operations must only be carried out by qualified experts.**

• **Disposal:** at the end of the life span of the automation system, make sure that it is dismantled by qualified experts and that the materials are disposed of in accordance with the applicable local regulations.

• **If the automation system was secured with the command "Secure automation system":** after a command is sent, the gate does not move and the flashing light emits 9 brief flashes.

SECURING AND RELEASING THE GEARMOTOR MANUALLY

The gearmotor is equipped with a mechanical system which allows the gate to be opened and closed manually.

These manual operations are required in the event of power cuts and operational faults.

Note - When there is no electrical power, the gate can still be moved using power from the back-up battery (mod. PS424), if included in your system.

Release (fig. A):

- 01.** Insert the key in the relative lock;
- 02.** Turn the key clockwise (90°);
- 03.** The lever comes out under action of a spring: turn the lever anti-clockwise through 90°;
- 04.** At this point the leaf can be moved manually to the required position.

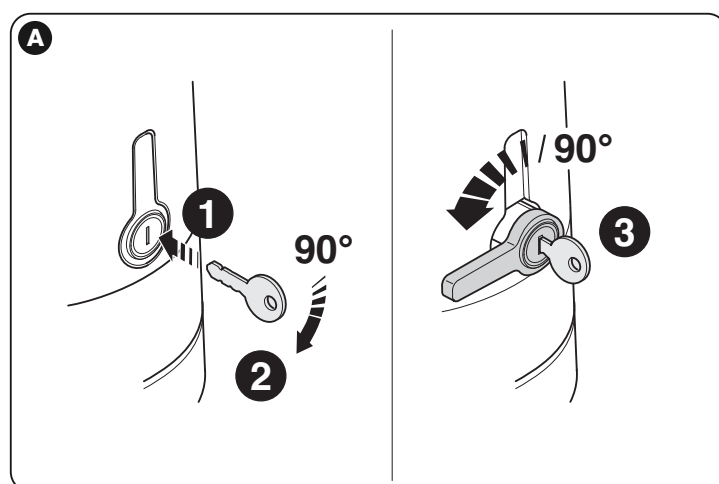

Lock (fig. B):

- 01.** Turn the lever through 90° to place the stem in a vertical position;
- 02.** Push the lever back into its seat;
- 03.** Turn the key anti-clockwise through 90° and remove.

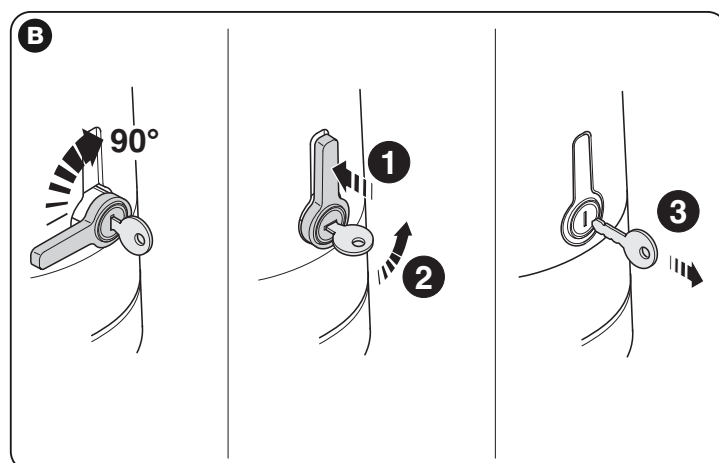

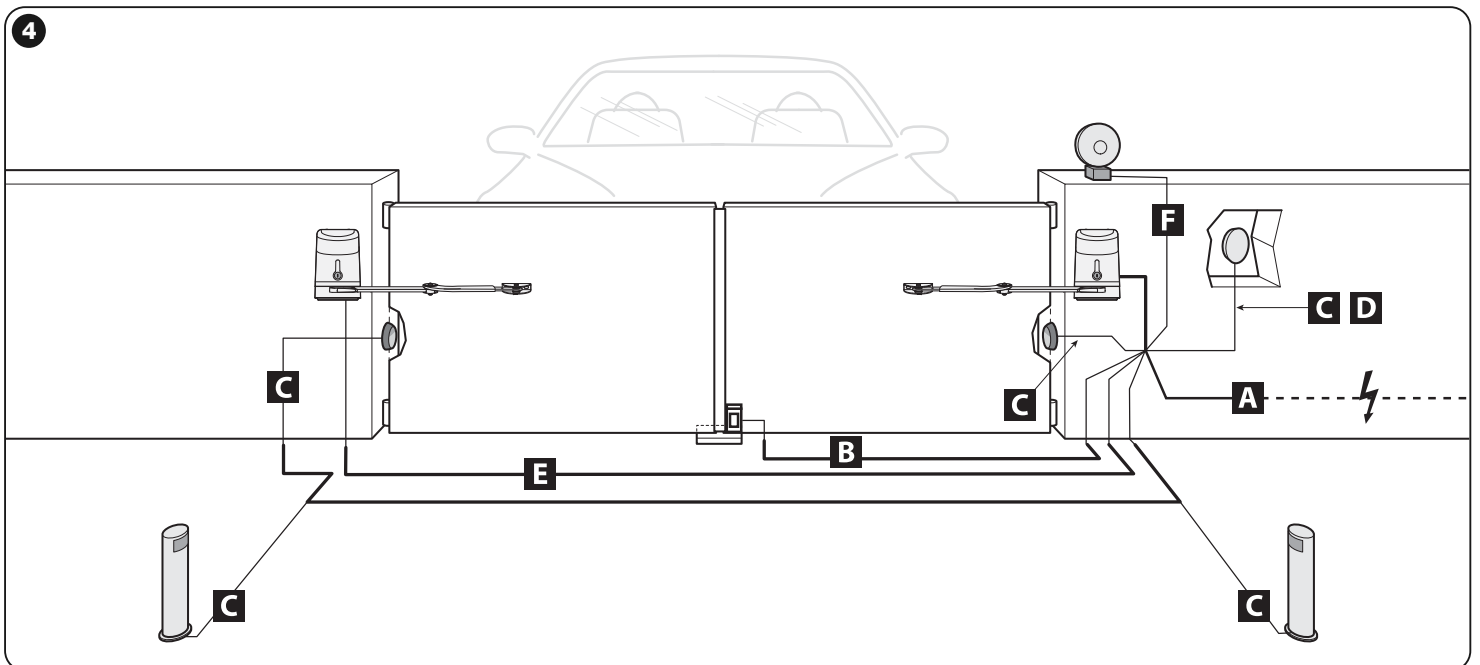
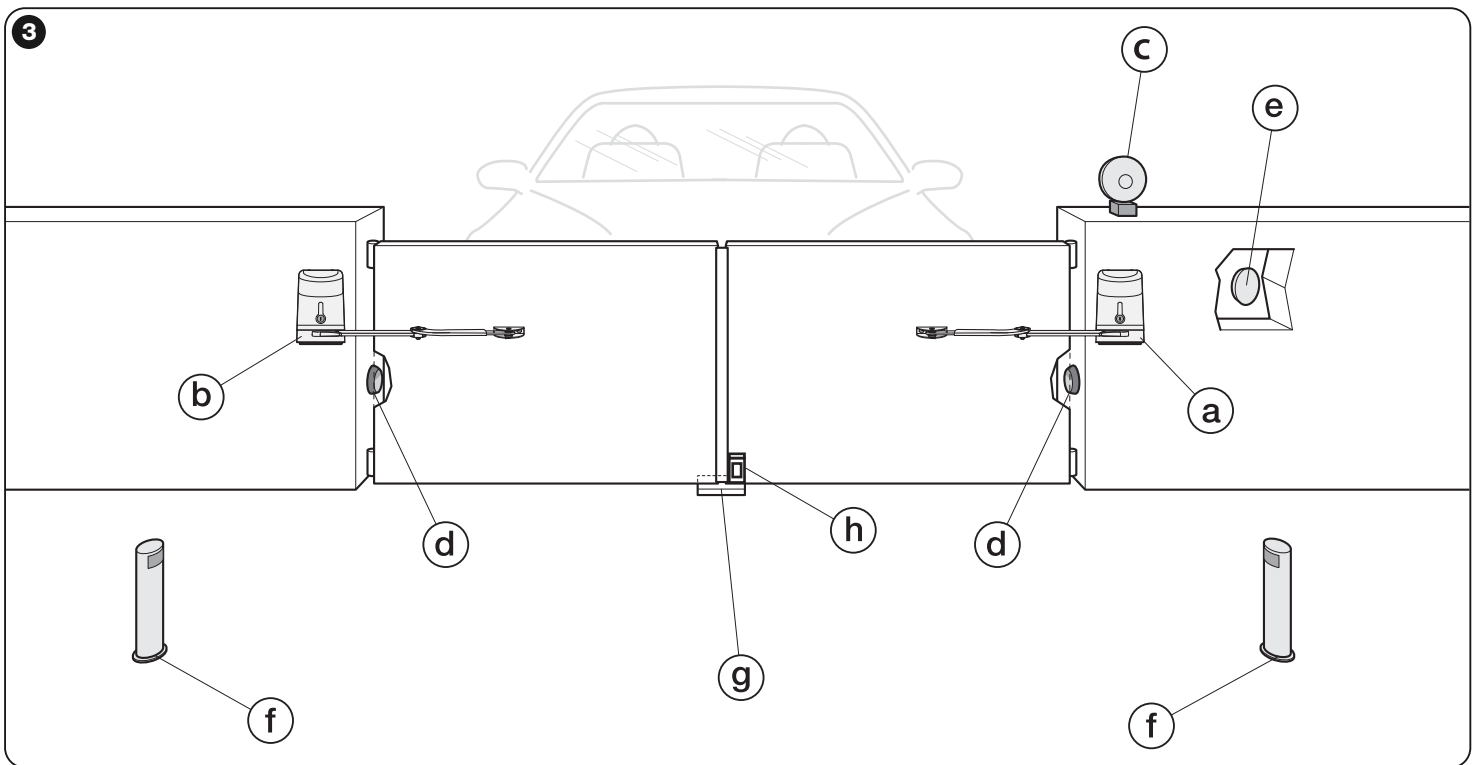
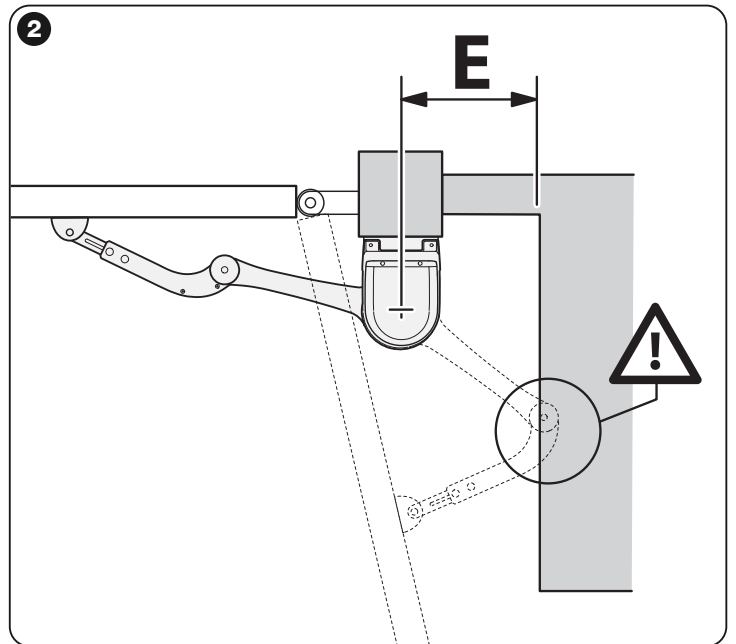
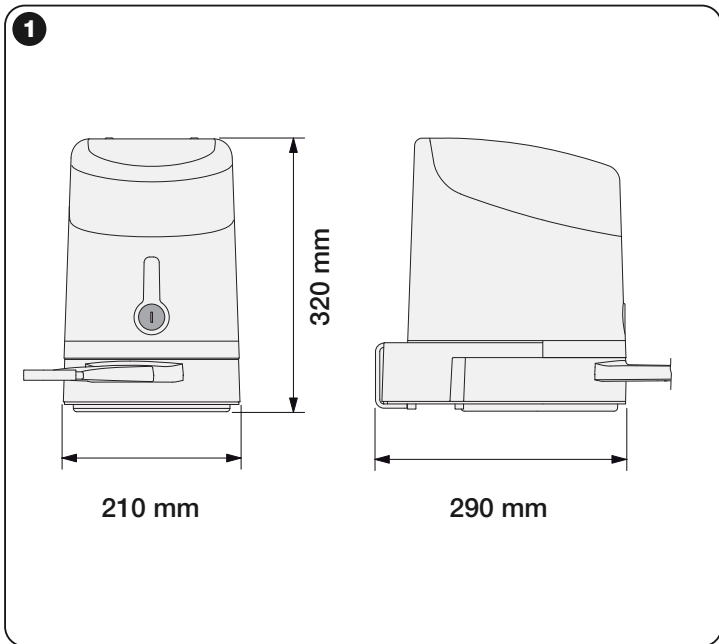

5

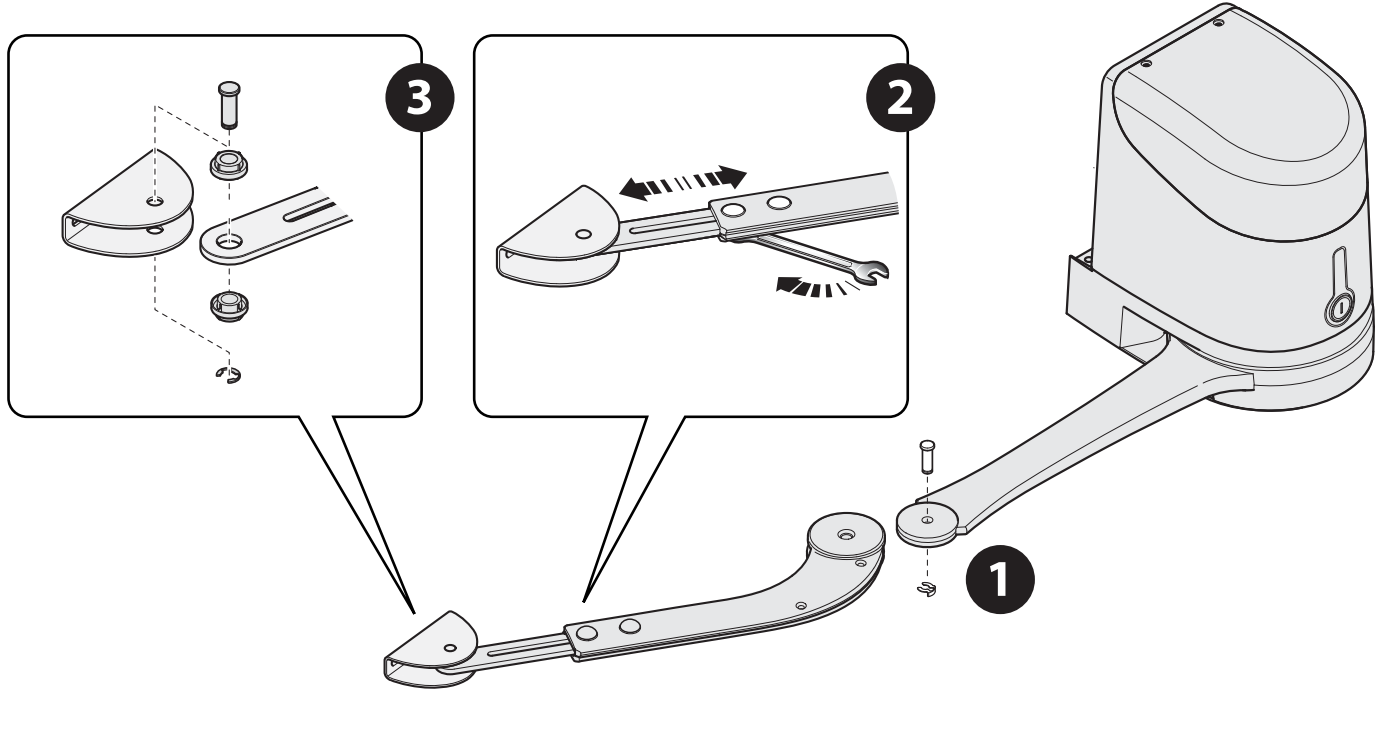

6

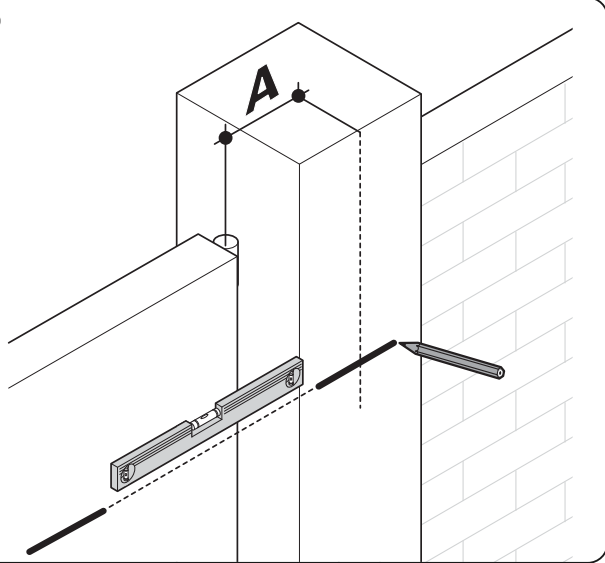

7

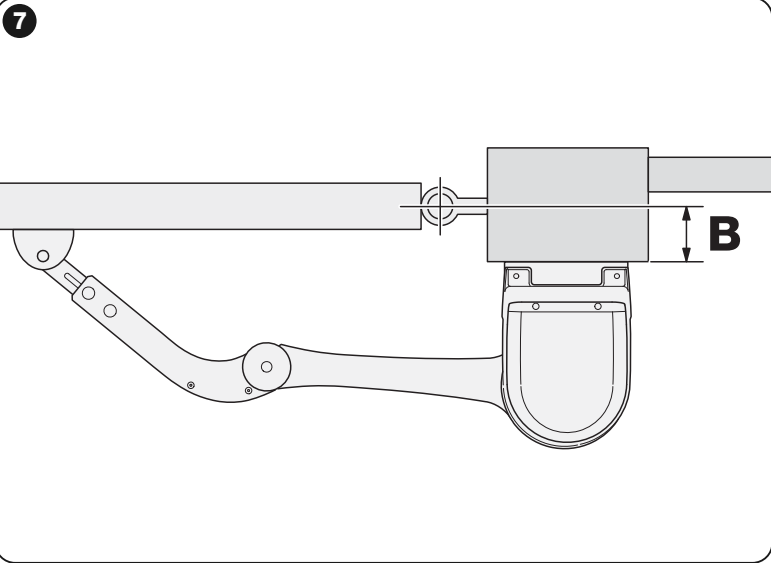

8

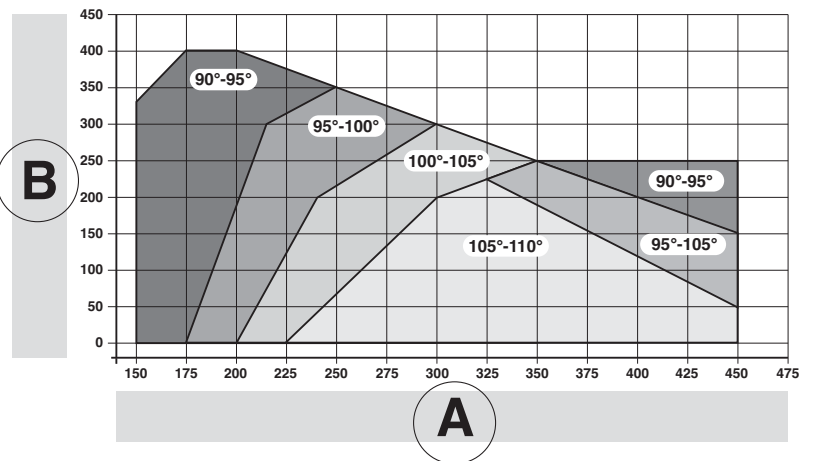
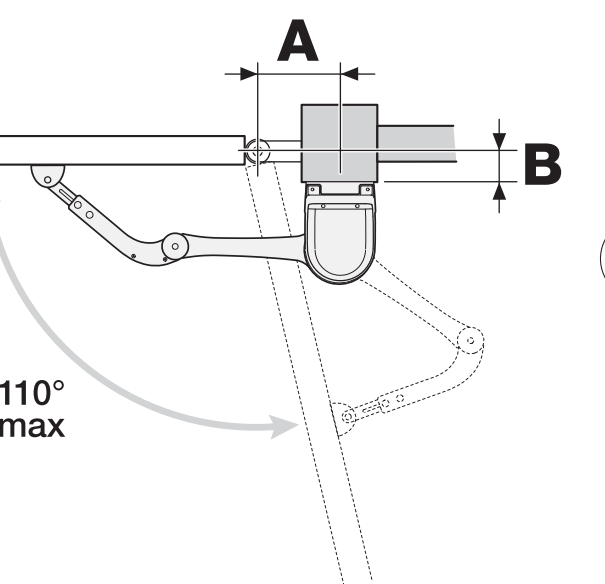

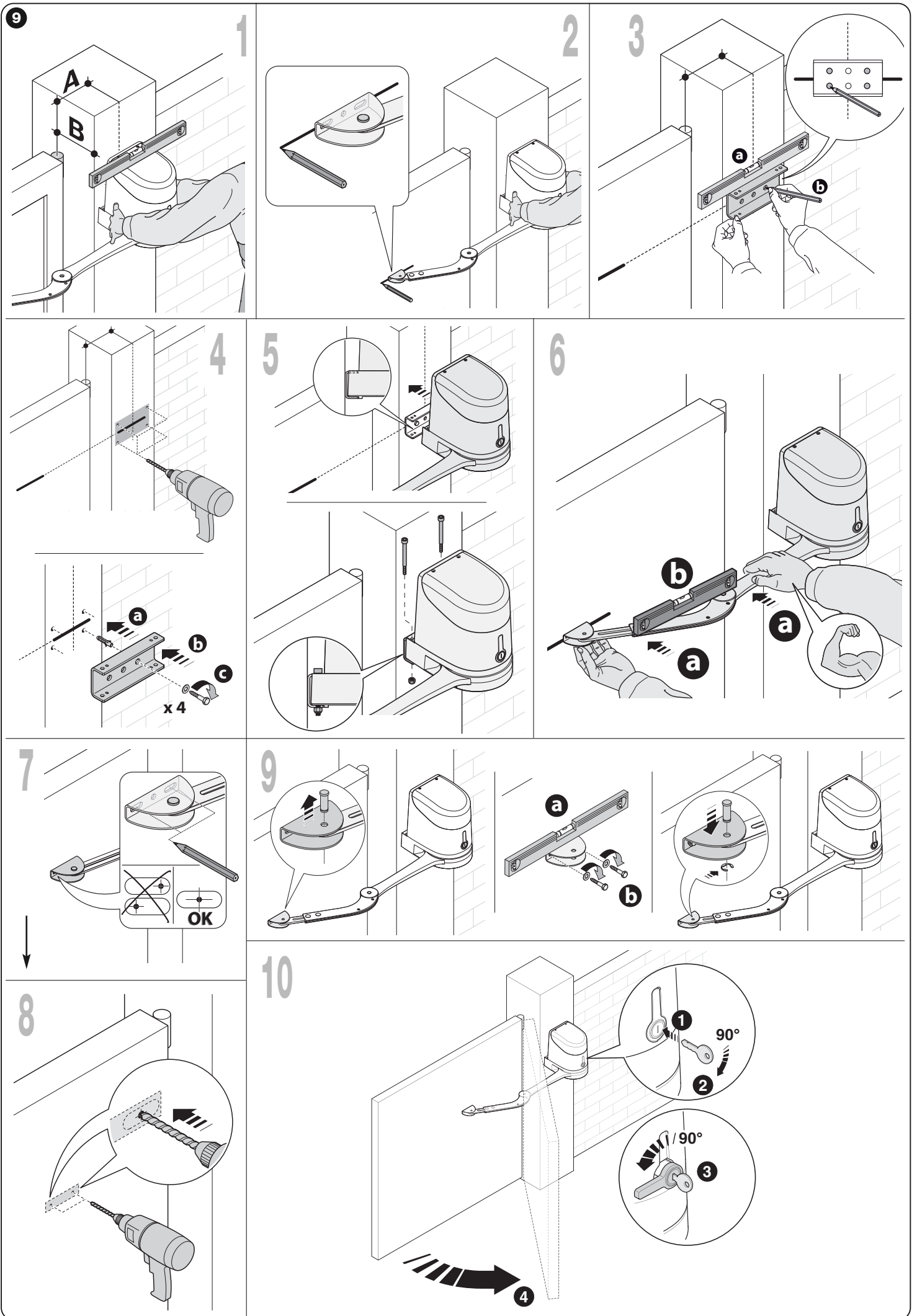

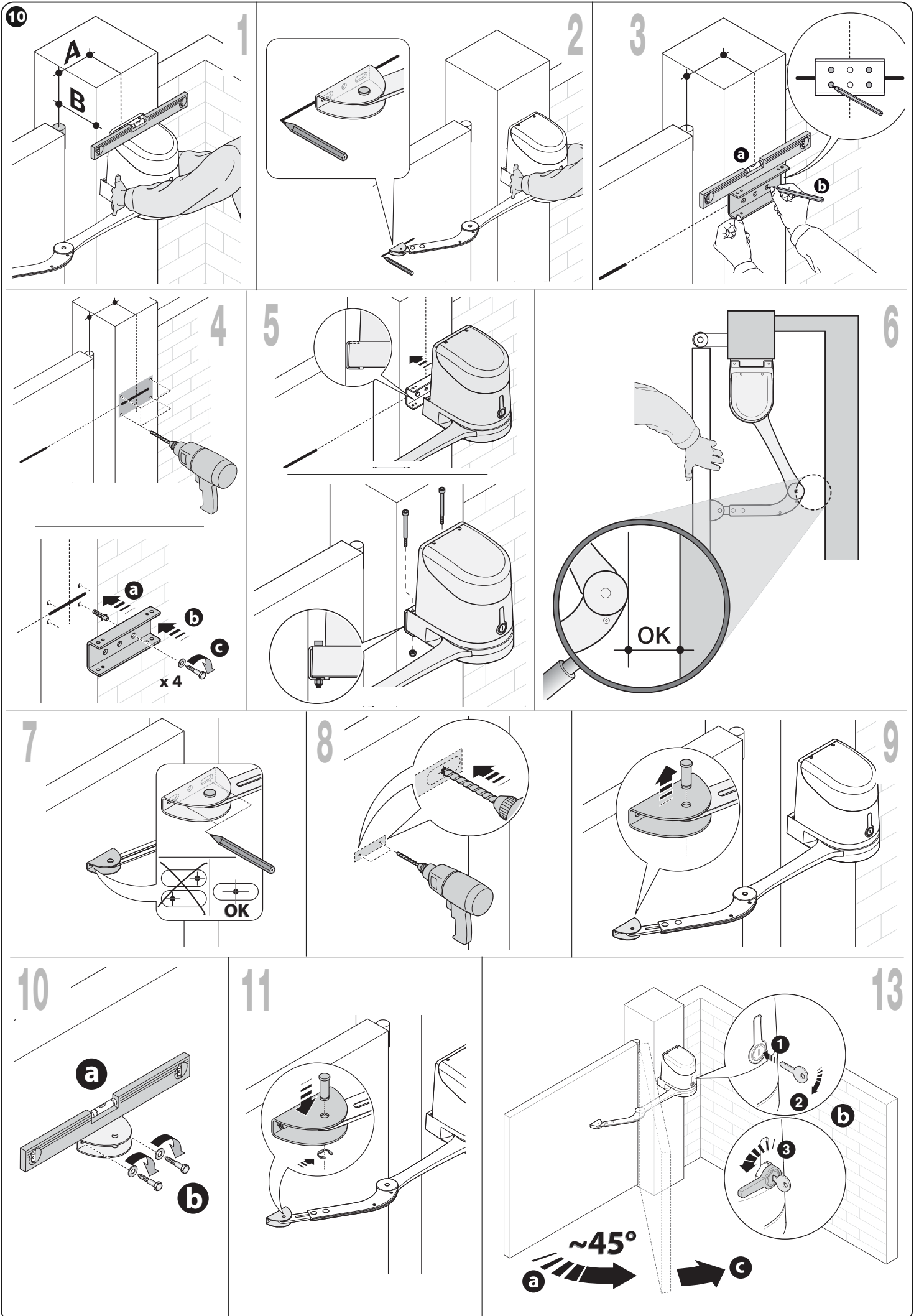

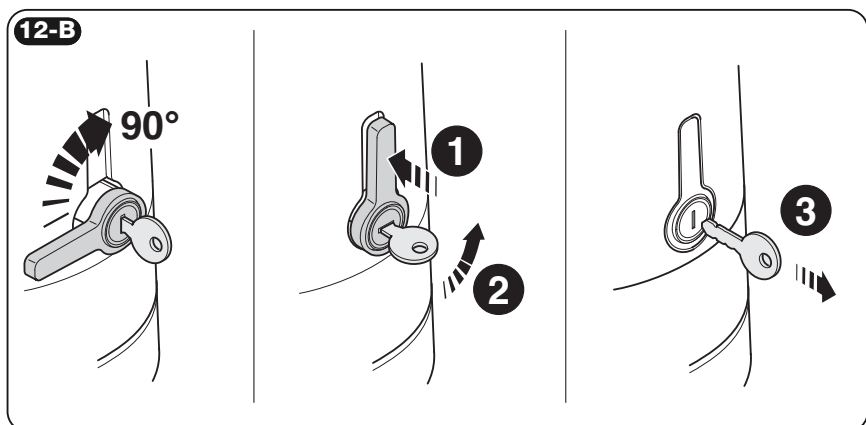
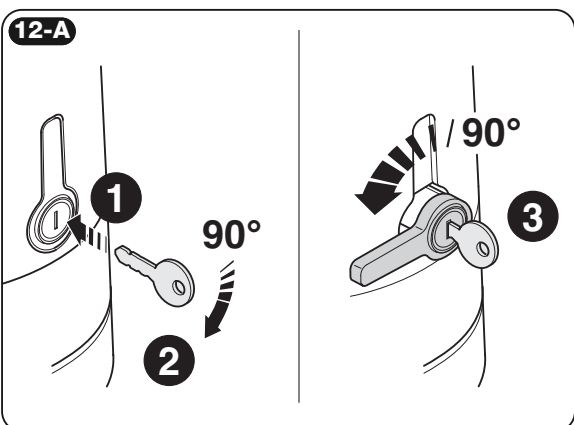
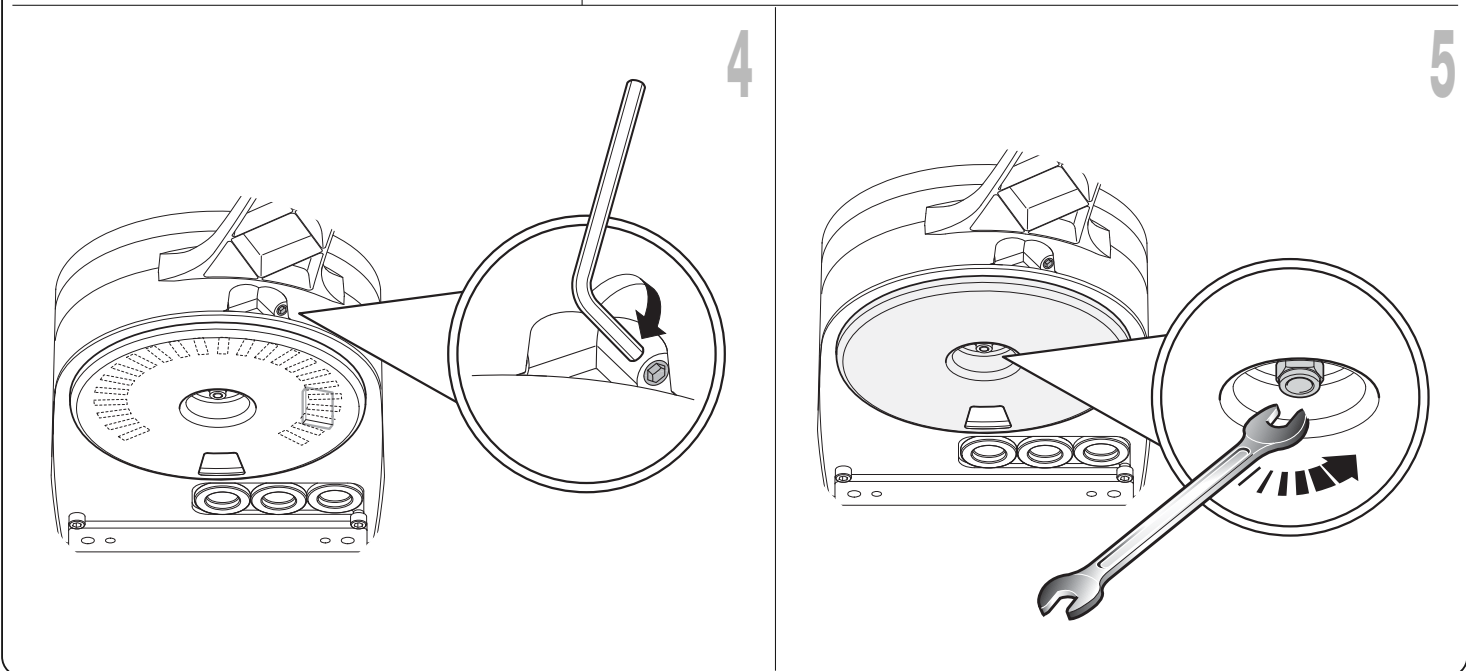
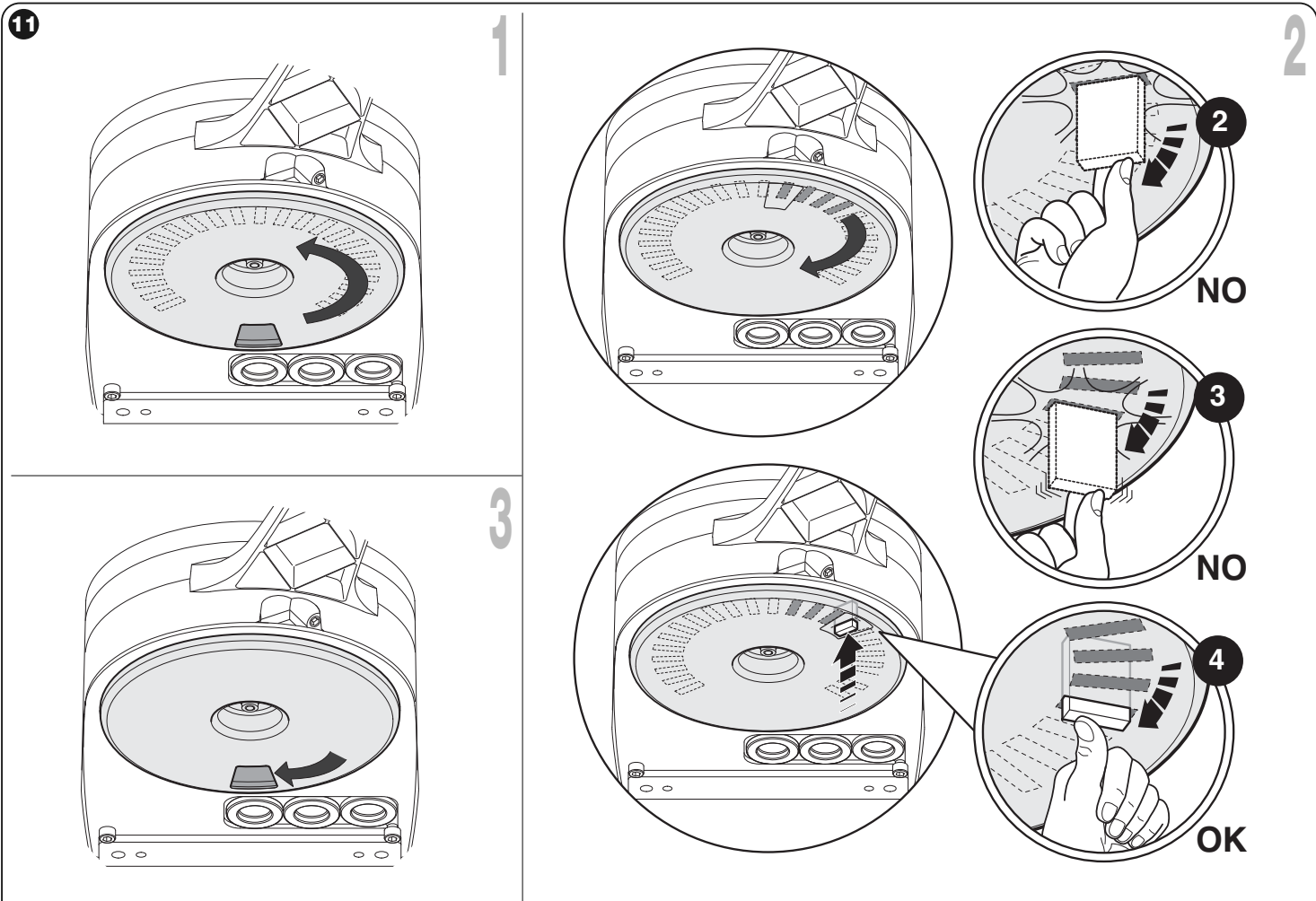

13

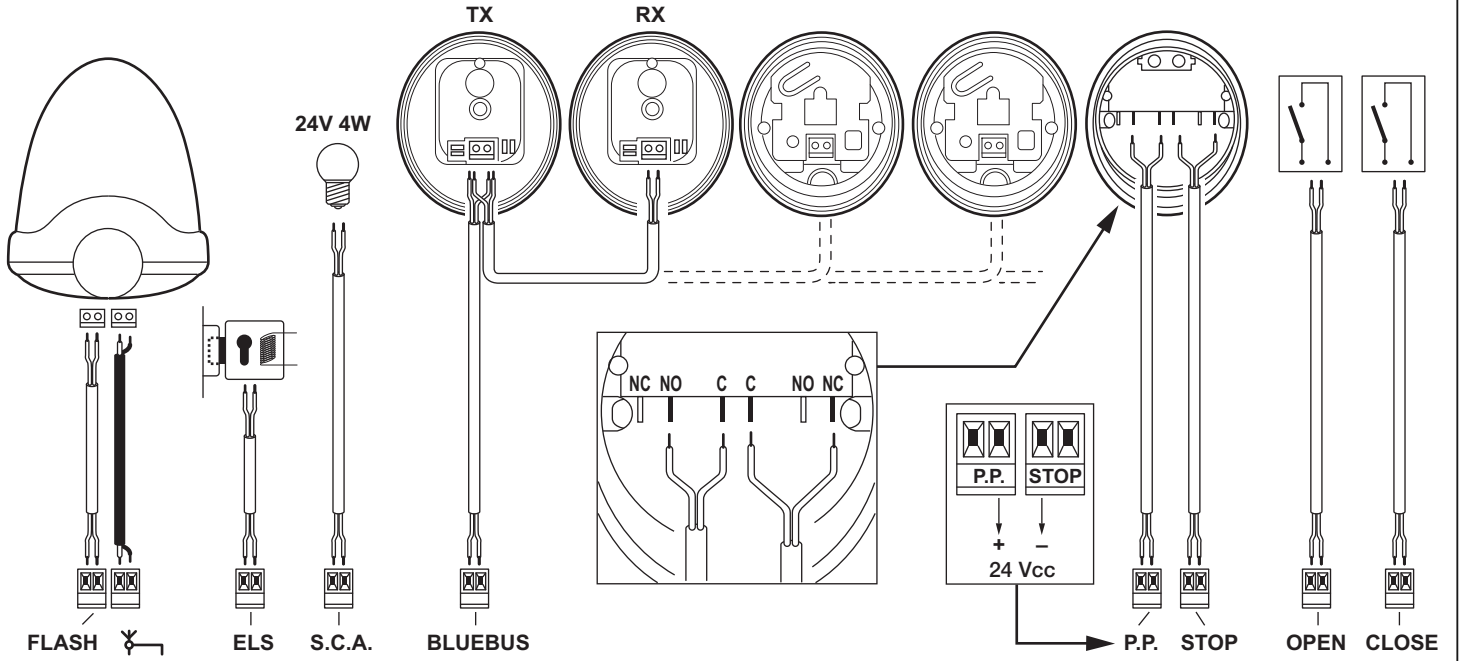

14

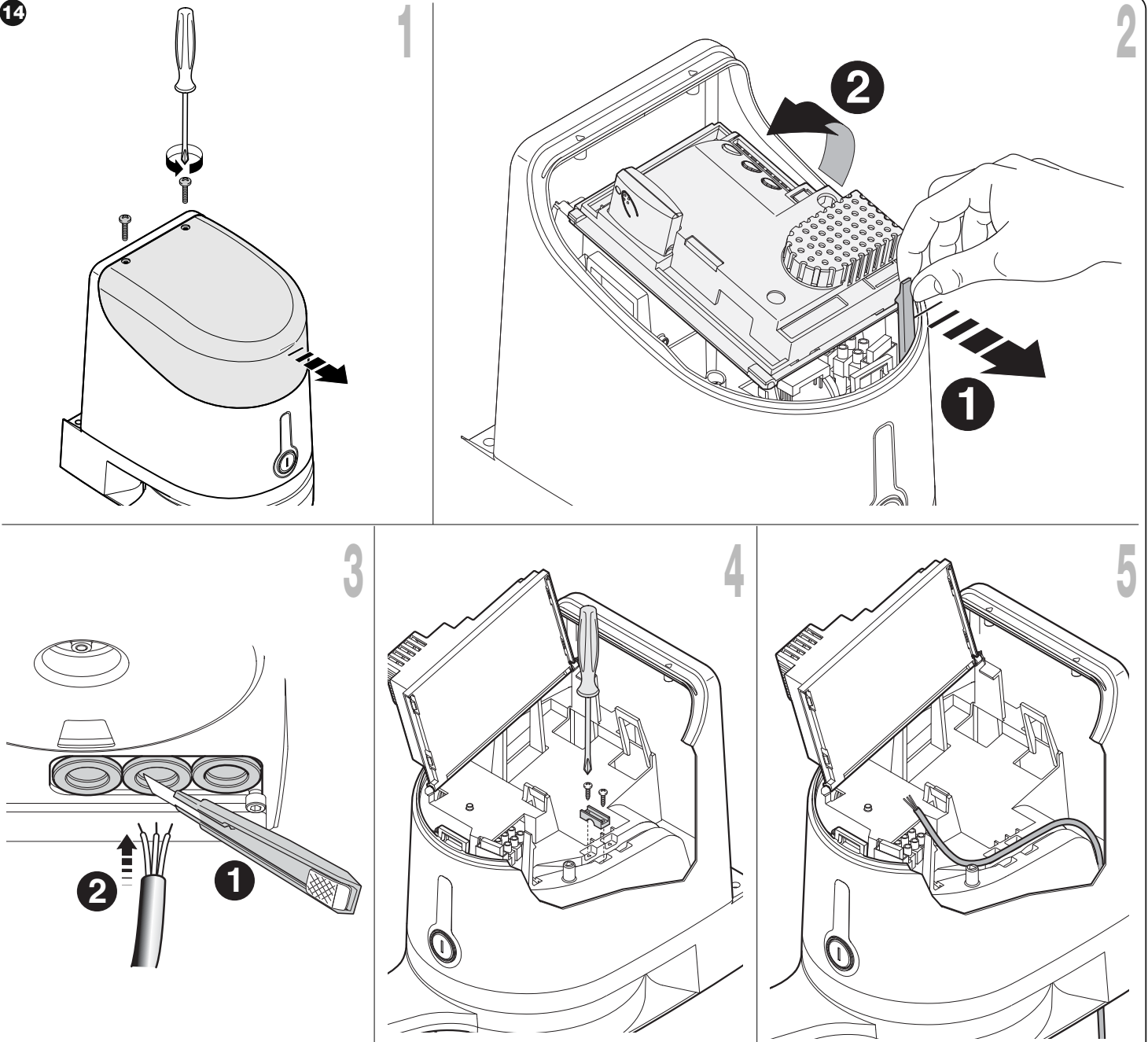

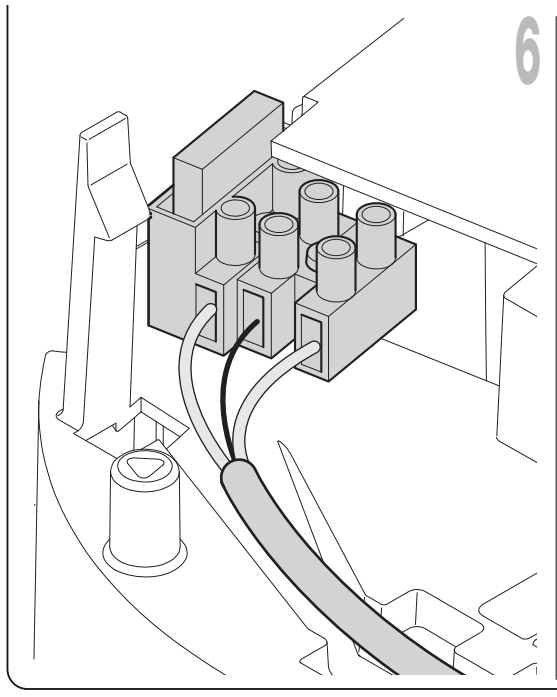

6

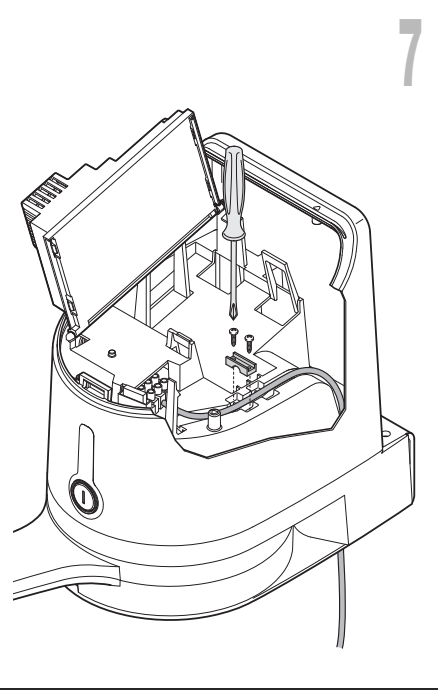

7

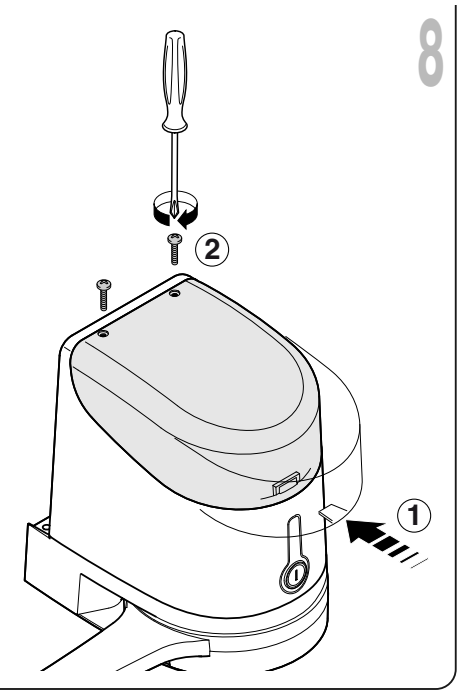

8

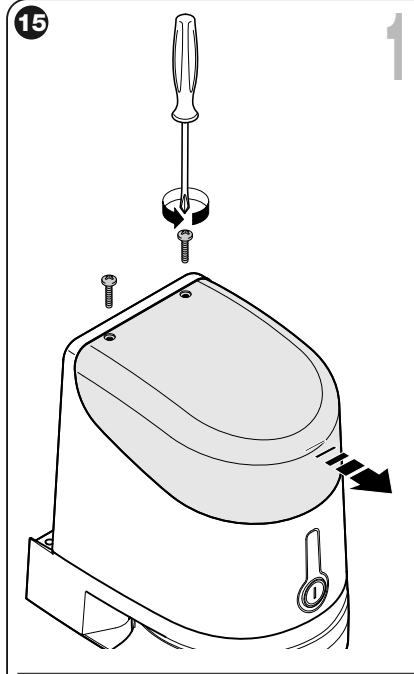

15

1

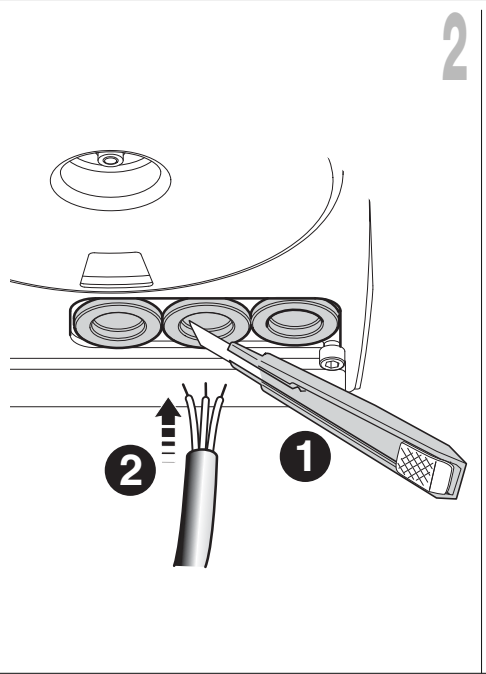

2

2

1

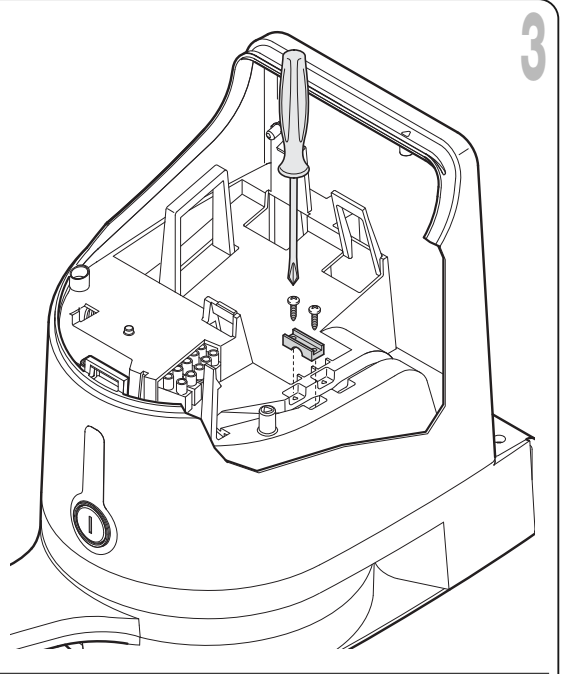

3

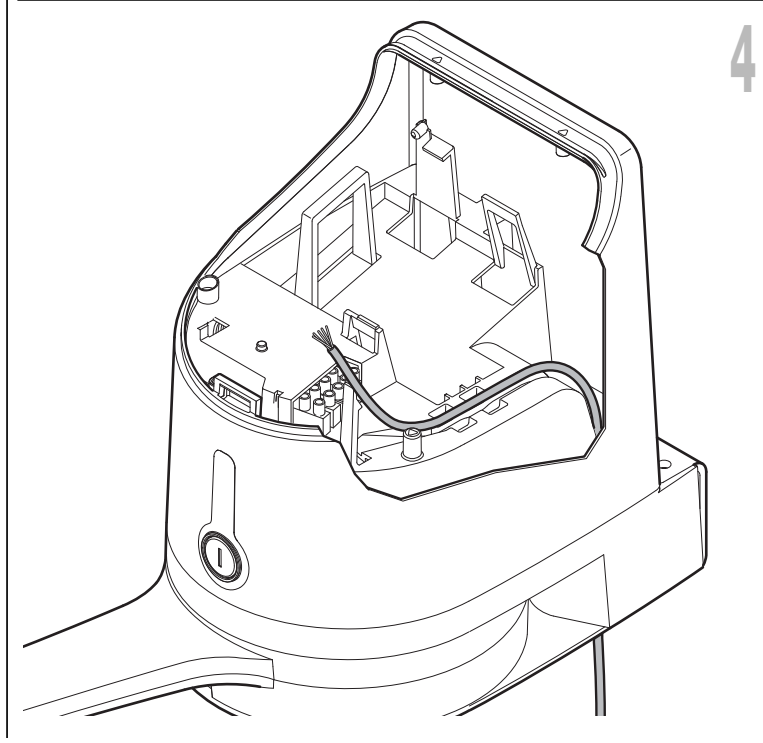

4

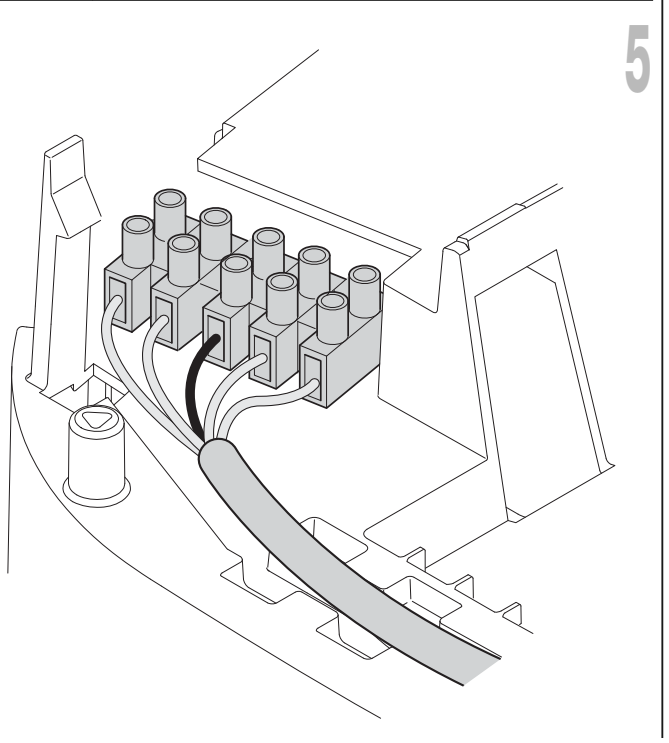

5

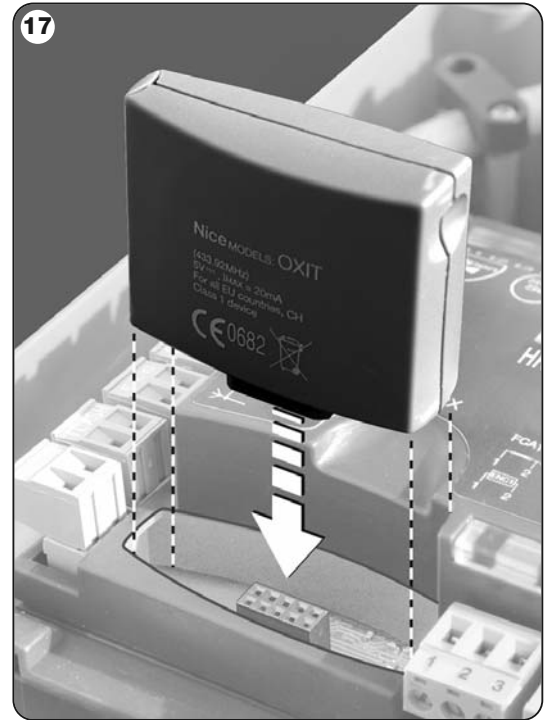
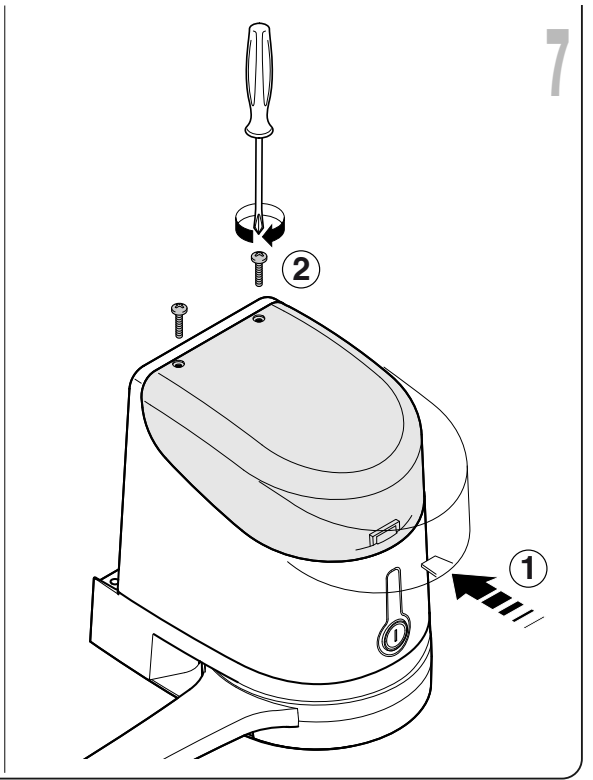
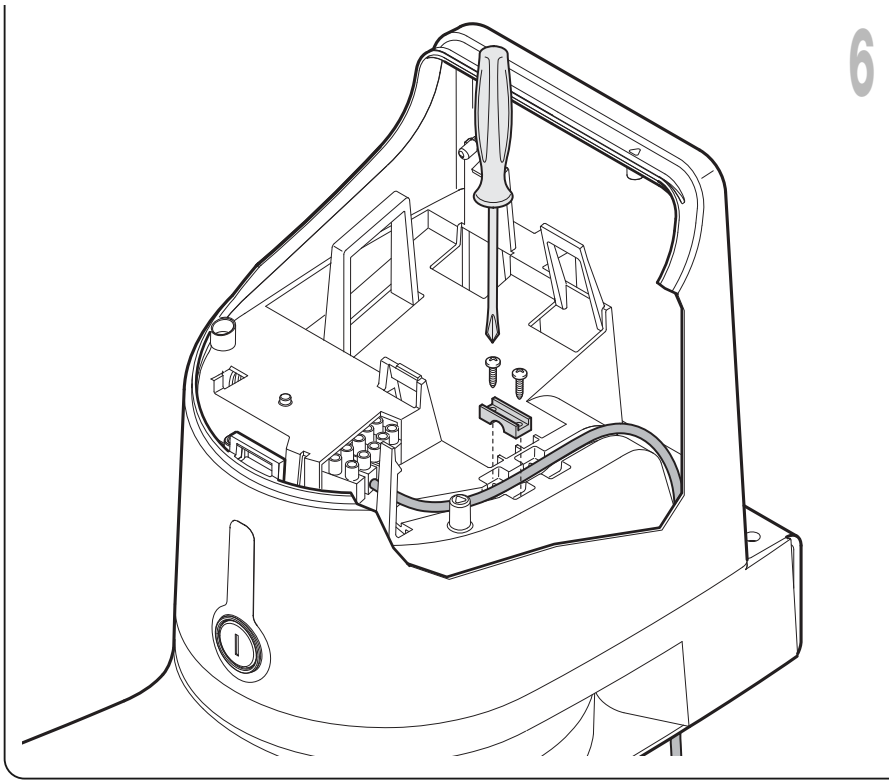

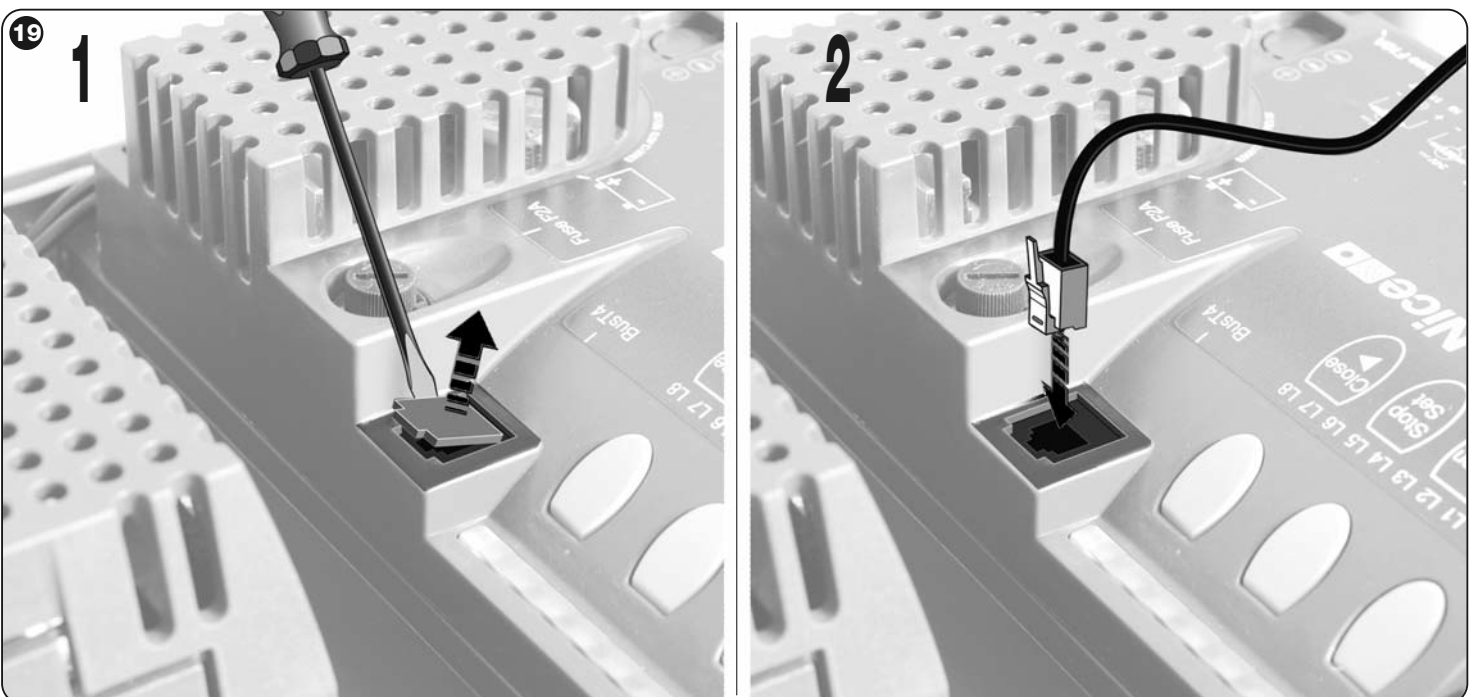
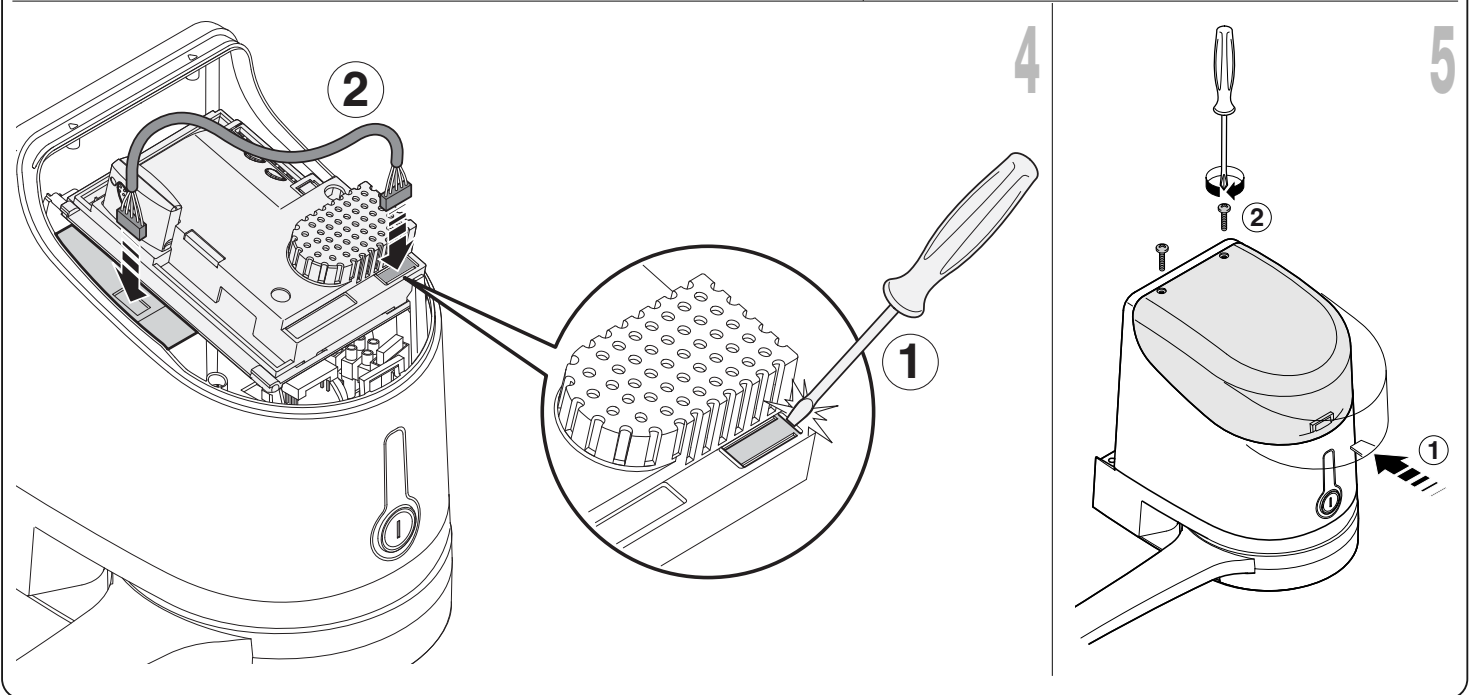
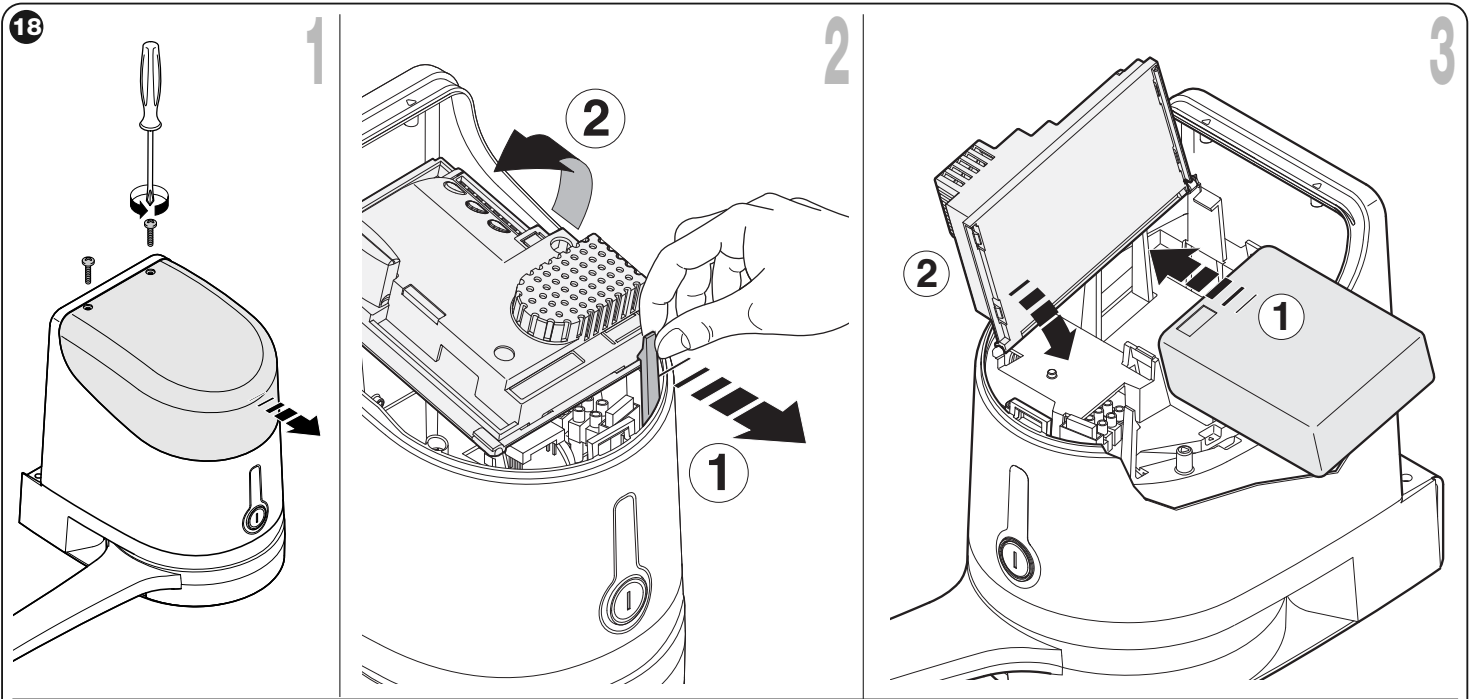

1

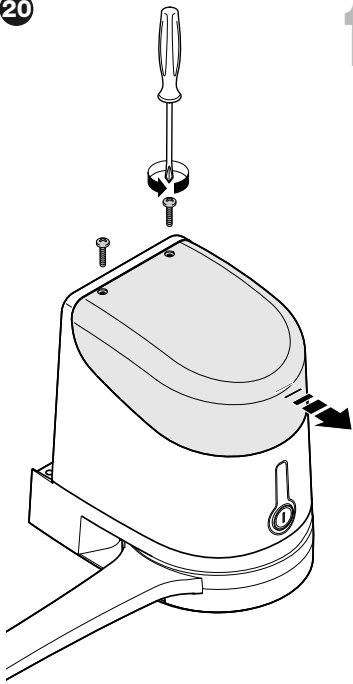

2

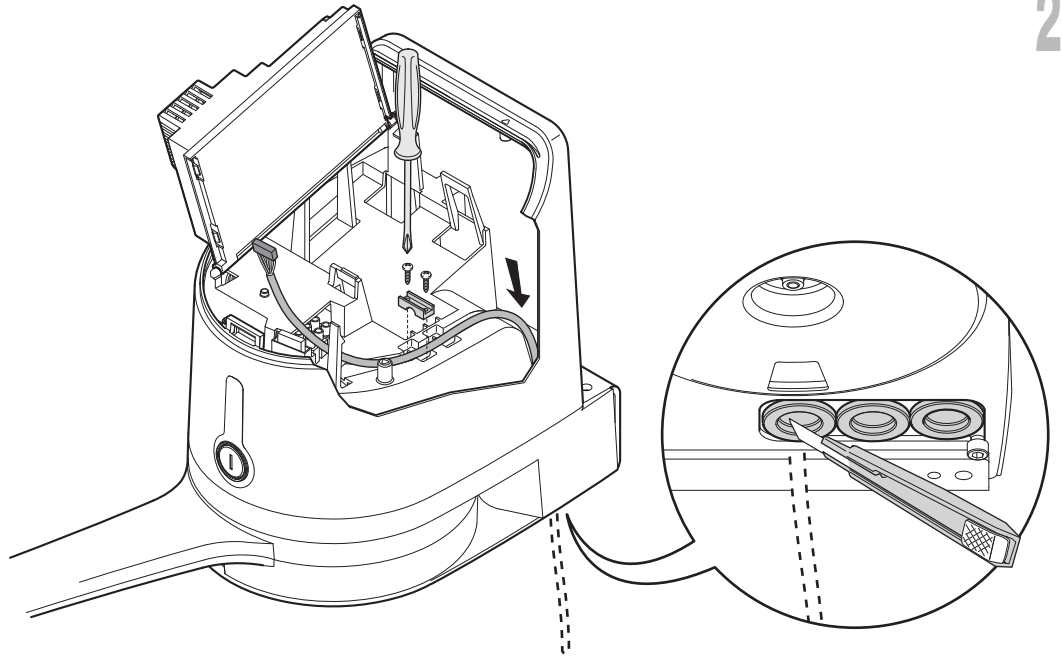

3

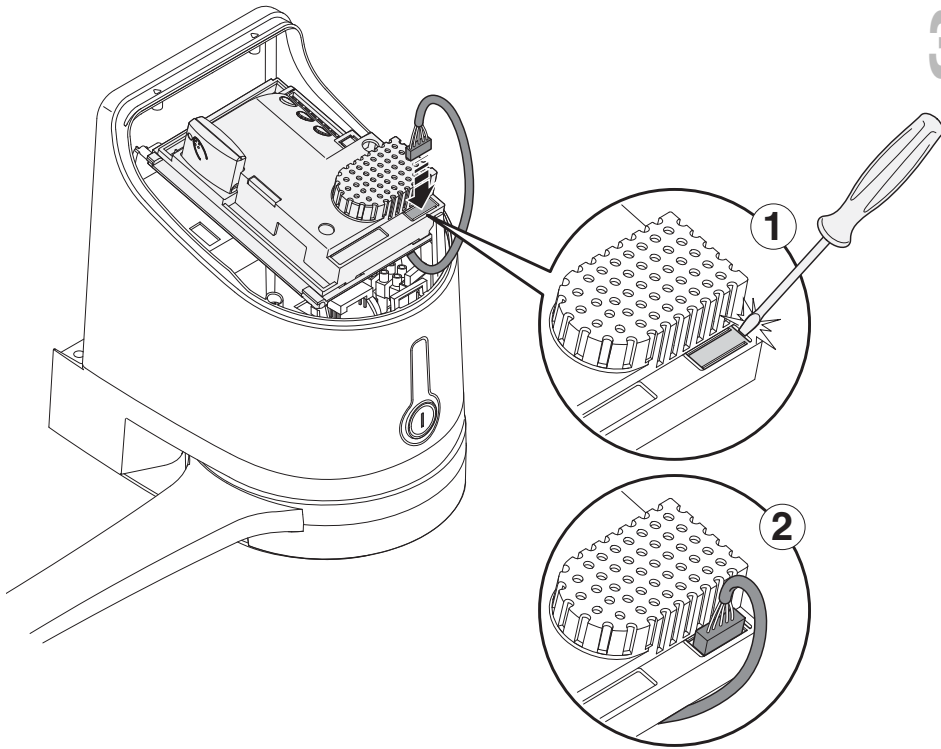

4

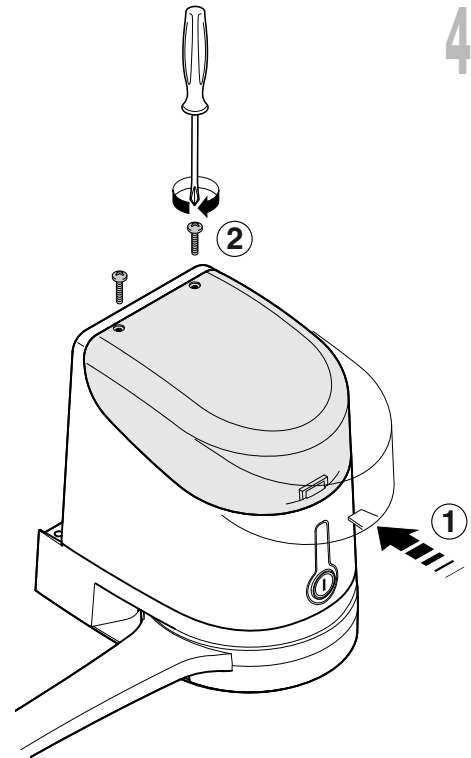

21

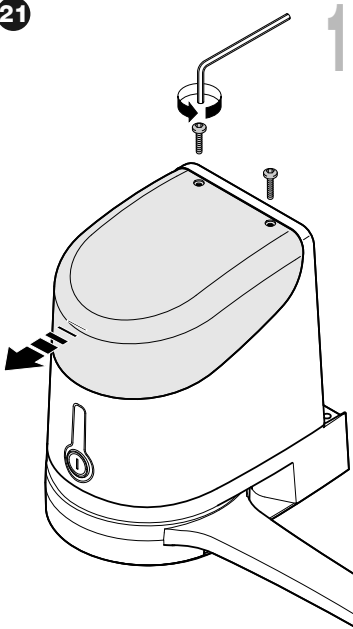

1

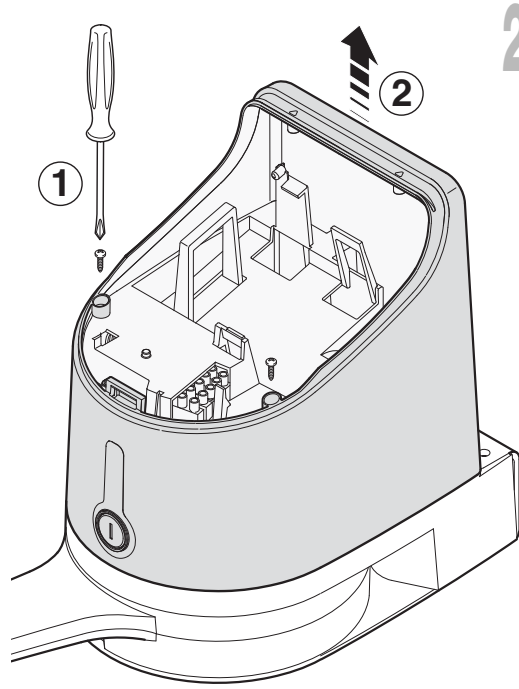

2

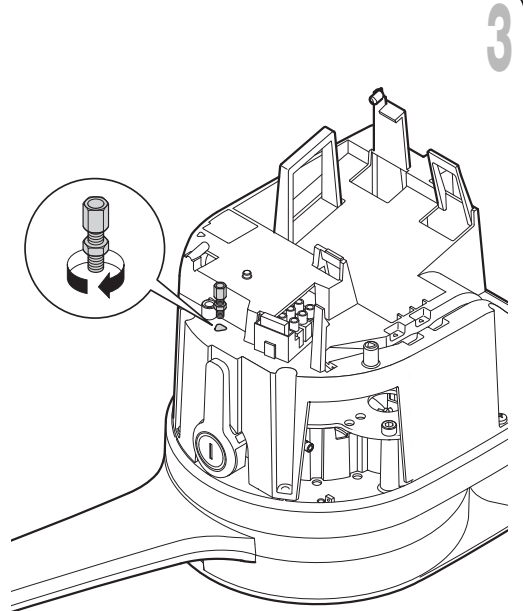

3

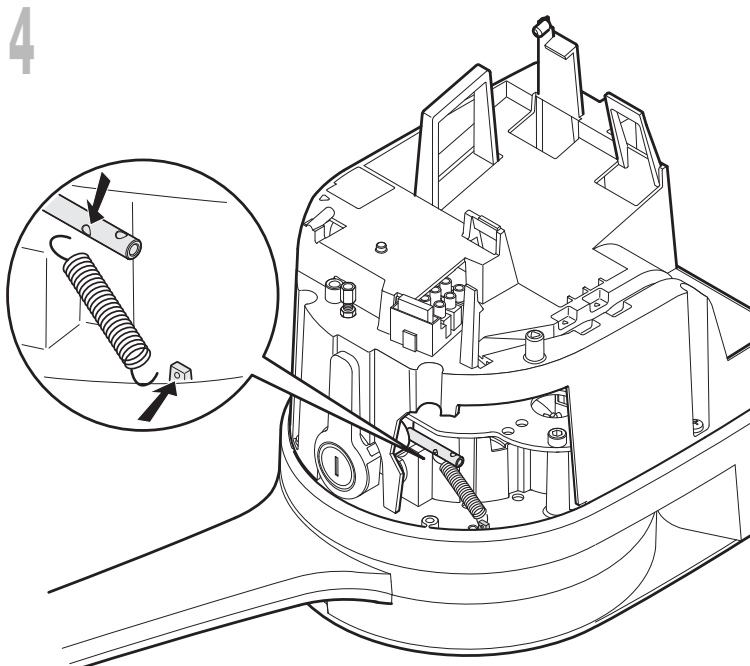

4

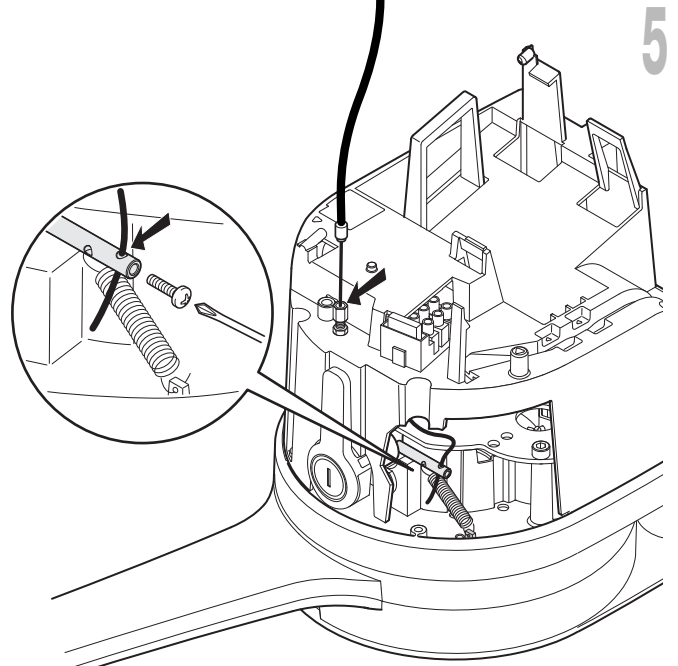

5

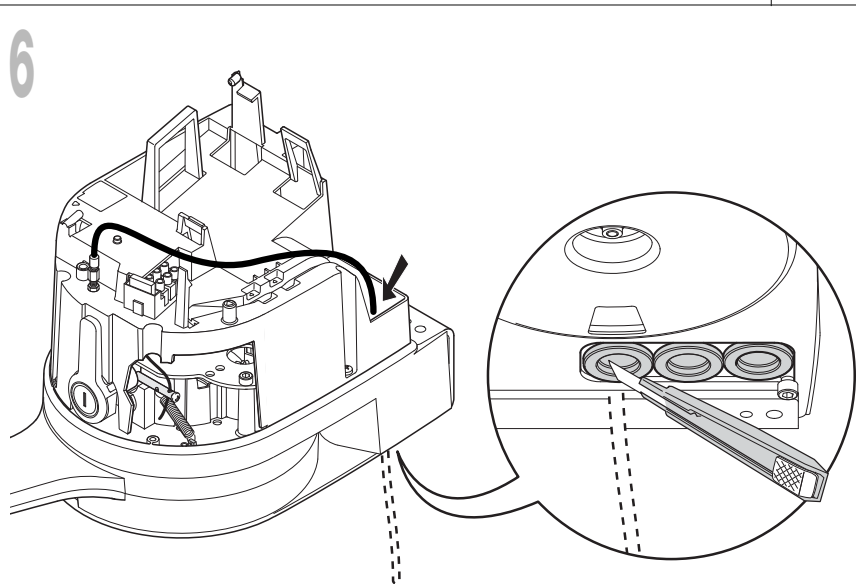

6

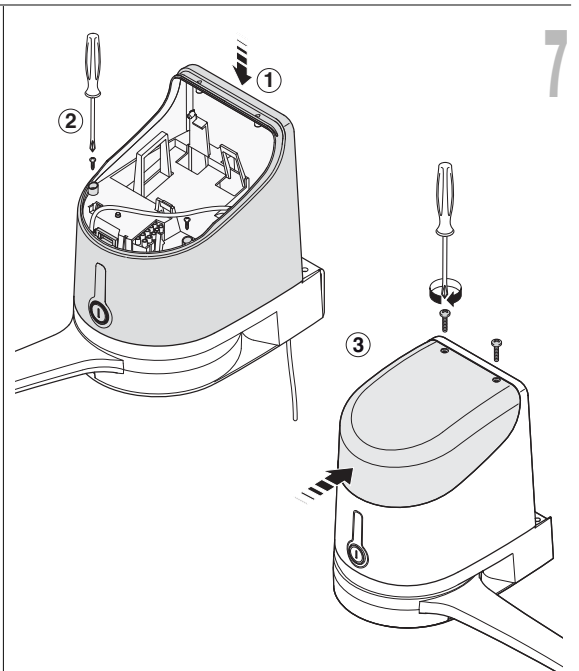

7

Nice

Headquarters

Nice SpA

Oderzo TV Italia
Ph. +39.0422.85.38.38
Fax +39.0422.85.35.85
info@niceforyou.com

Nice in Italy

Nice Padova

Padova Italia
Ph. +39.049.87.01.05.1
Fax +39.049.87.07.63.8
infopd@niceforyou.com

Nice Roma

Roma Italia
Ph. +39.06.72.67.17.61
Fax +39.06.72.67.55.20
inforoma@niceforyou.com

Nice Worldwide

Nice France

Buchelay France
Ph. +33.(0)1.30.33.95.95
Fax +33.(0)1.30.33.95.96
info@fr.niceforyou.com

Nice France Sud

Aubagne France
Ph. +33.(0)4.42.62.42.52
Fax. +33.(0)4.42.62.42.50
infomarseille@fr.niceforyou.com

Nice France Rhône Alpes

Decines Charpieu France
Ph. +33.(0)4.78.26.56.53
Fax +33.(0)4.78.26.57.53
infoyon@fr.niceforyou.com

Nice Belgium

Leuven (Heverlee) Belgium
Ph. +32.(0)16.38.69.00
Fax +32.(0)16.38.69.01
info@be.niceforyou.com

Nice Deutschland

Gelnhausen Deutschland
Ph. +49.(0)6051.91.520
Fax +49.(0)6051.91.52.119
info@de.niceforyou.com

Nice España Madrid

Mostoles Madrid España
Ph. +34.(0)9.16.16.33.00
Fax +34.(0)9.16.16.30.10
info@es.niceforyou.com

Nice España Barcelona

Sant Quirze del Valles
Barcelona España
Ph. +34.(0)9.37.84.77.75
Fax +34.(0)9.37.84.77.72
info@es.niceforyou.com

Nice Australia

Wetherill Park Australia
Ph. +61.(0)2.96.04.25.70
Fax +61.(0)2.96.04.25.73
info@au.niceforyou.com

Nice China

Shanghai P. R. China
Ph. +86.21.575.701.46
Fax +86.21.575.701.44
info@niceforyou.com.cn

Nice USA

San Antonio Texas USA
info@us.niceforyou.com

Nice Russia

Odintsovo Moscow Region Russia
Ph. +7.495.739.97.02
Fax +7.495.739.97.02
info@ru.niceforyou.com

Nice South Africa

Johannesburg South Africa
info@co.za.niceforyou.com

Nice Polska

Pruszków Polska
Ph. +48.(022).759.40.00
Fax +48.(022).759.40.22
info@pl.niceforyou.com

Nice Portugal

Mem Martins Portugal
Ph. +351.21.922.82.10
Fax +351.21.922.82.19
info@pt.niceforyou.com

Nice Romania

Cluj Napoca Romania
Ph./Fax +40.(0)264.453.127
info@ro.niceforyou.com

Nice Turkey

Kadikoy Istanbul Turkey
Ph. +90.216.456.34.97
Fax +90.216.455.78.29
info@tr.niceforyou.com

Nice UK

Sutton in Ashfield
United Kingdom
Ph. +44.16.23.55.80.86
Fax +44.16.23.55.05.49
info@uk.niceforyou.com