

RO500

CE 0682

Sliding gate opener

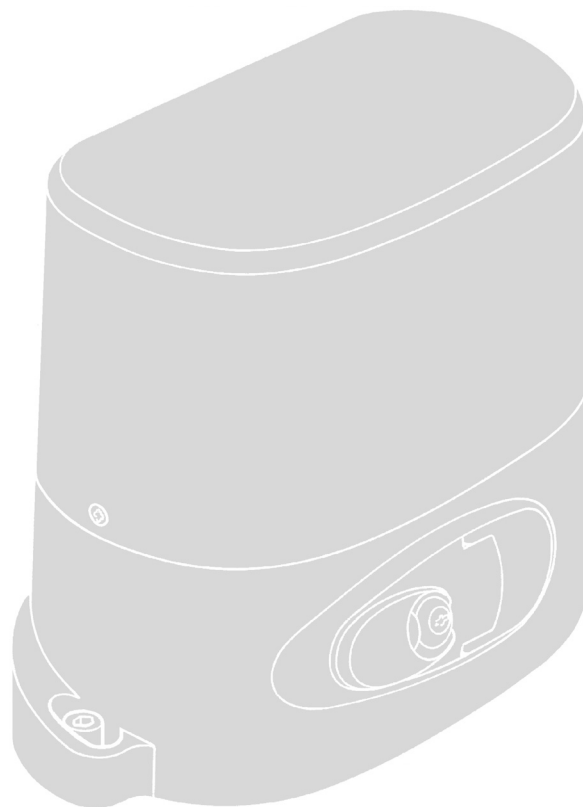

EN - Instructions and warnings for installation and use

Manual override procedure - Page 8

Nice

1 GENERAL SAFETY WARNINGS AND PRECAUTIONS

WORKING IN SAFETY!

- **CAUTION! – Important instructions: Keep this manual in a safe place to enable future product maintenance and disposal operations.**
- **CAUTION! – All installation procedures, connections, programming and maintenance of the product must be performed exclusively by a qualified technician!**

Considering the hazards that may occur during installation and use, maximum safety is only ensured if the product is installed in strict observance of current legislation, standards and regulations. This chapter contains general warnings, while other important warnings are provided in chapters 3 “Installation” and 7 “Testing and commissioning”.

According to the most recent legislation, the installation of an automatic gate or door must be in full observance of the standards envisaged by European Directive 98/37/EC (Machinery Directive) and in particular standards: EN 13241-1 (harmonised standard); EN 12445; EN 12453 and EN 12635, which enable declaration of conformity with the machinery directive.

Further information, with guidelines to risk assessments and the drafting of the Technical Documentation can be found on the website www.niceforyou.com. This manual, excluding the detachable appendix “Operation Manual” for the installer, is aimed exclusively at technical personnel qualified for installation; no other information in this documentation can be considered of interest to the user.

- Use of the product other than as described in this manual is strictly prohibited; improper use can lead to danger, physical injury or damage to objects.
- Before installation, an assessment of the associated risks must be made, including a list of the essential safety requirements as envisaged in Appendix I of the Machinery Directive, specifying the relative solutions adopted.

Note that the risk assessment is one of the documents included in the automation Technical documentation.

- Check whether other devices are needed to complete the automation on the basis of the specific conditions of use and dangers present; take into account all risks of impact, crushing, shearing, dragging etc. and other hazards in general.
- Never make any modifications to parts if not envisaged in these instructions; operations of this type will lead to malfunctions; NICE declines all liability for damage caused by modified products.
- During installation and use, ensure that no solids or liquids can penetrate the control unit or other open devices; if necessary contact the NICE assistance service; use in these conditions may constitute a hazard.
- The automation may only be used after completing the “commissioning” procedure as specified in chapter 5 “Testing and commissioning”.
- The product packaging material must be disposed of in full observance of current local legislation governing waste disposal.
- In the event of faults not solved with the information in this manual, contact the NICE assistance service.
- If an automatic circuit breaker trips or a fuse blows, identify and eliminate the fault before restoring normal operating conditions.

- Before accessing internal terminals under the cover, disconnect all power circuits. If the disconnect device is not in a visible location, affix a notice stating: “WARNING: MAINTENANCE IN PROGRESS”.

Special warnings regarding suitability of product use in relation to the “Machinery” Directive” 98/37/EC (ex 89/392/EEC):

- This product is issued onto the market as a “machine component” and is therefore constructed for incorporation in a machine or for assembly with other machinery to obtain “a machine” in accordance with the Directive 98/37/EC only in combination with the other components and using the methods as described in this instruction manual. As envisaged in the directive 98/37/EC, start-up of the product specified above is not admitted unless the manufacturer of the machine, in which the product is incorporated, has identified and declared the machine as conforming to directive 98/37/EC.

Special warnings regarding suitability of product use in relation to the “Low Voltage” Directive” 2006/95/EEC:

- This product meets the requirements of the “Low Voltage” Directive if

used as specified in the configurations as envisaged in this instruction manual and in combination with the articles listed in the product catalogue of Nice S.p.a. These requirements may not be guaranteed if the product is used in configurations or with other products not envisaged; use of the product in these situations is strictly prohibited unless the installer has verified that all requirements of the directive have been met.

Special warnings regarding suitability of product use in relation to the “Electromagnetic Compatibility” Directive” 2004/108/EEC:

- This product has undergone all tests regarding electromagnetic compatibility in the most critical conditions of use, in the configurations as envisaged in this instruction manual and in combination with the articles listed in the product catalogue of Nice S.p.a. Electromagnetic compatibility may not be guaranteed if the product is used in configurations or with other products not envisaged; use of the product in these situations is strictly prohibited unless the installer has verified that all requirements of the directive have been met.

2 PRODUCT DESCRIPTION AND INTENDED USE

RO500 is designed to automate sliding gates for residential applications. **Any other use than as specified herein or in environmental conditions other than as stated in this manual is to be considered improper and is strictly prohibited!**

The gearmotor comprises a 230 V ac motor, a pinion and a control unit.

The control unit powers all devices present in the system and manages all relative functions. It is made up of a board and incorporated multi-code radio receiver which receives the commands sent by a transmitter. Special functions are also available to enable personalisation of automation use.

The automation enables the installation of various accessories which enhance functionality and guarantee optimal safety.

The product is mains-powered, and, in the event of a power failure enables manual release of the gearmotor for manual movement of the gate.

3 INSTALLATION

3.1 - Preliminary installation checks

Before proceeding with installation, check the condition of the product components, suitability of the selected model and conditions of the intended installation environment.

IMPORTANT – The gearmotor cannot be used to power a manual gate that does not have a fully efficient and safe mechanical structure. Neither can it solve defects caused by poor installation or insufficient maintenance of the door itself.

3.2 - Checking suitability of the environment and gate to be automated

- Ensure that the mechanical structure of the gate complies with current national standards and that it is suitable for automation. (*If present, refer to the information specified on the gate dataplate*).

- Ensure that the weight and dimensions of the leaf are within the application limits as specified in paragraph 3.3 “Application limits”.

- With reference to the values specified in chapter “Product technical specifications”, ensure that:

- the force required to move the gate leaf, is less than half the value of the force corresponding to the “Maximum Torque”;

- the force required to maintain gate movement, is less than half the value of the force corresponding to the “Nominal Torque”. *Note – To set the force value, a margin of 50% is recommended as adverse weather conditions could increase the degree of friction.*

- Move the gate leaf manually to open and close, checking that movement has the same degree of friction throughout all points of travel (*no increase in friction must occur*).

- Manually move the leafs to any position and leave stationary, ensuring that they do not move from this position and that the gate leaf remains balanced.
- Ensure that there is no risk of gate leaf guides coming out of their seats.
- Ensure that the gearmotor fixing zone is not subject to the risk of flooding; if necessary install the gearmotor in a position raised from the ground.
- Ensure that the space around the gearmotor enables safe and easy manual gate release.
- Ensure that the crushing points between the gate leaf and fixed parts of the latter are protected during the *Opening* and *Closing* manoeuvres.
- Ensure that the selected surfaces for installation of the various devices are solid and guarantee a stable fixture. In particular, ensure that the selected surfaces for fixing the photocells are flat and enable correct alignment between photocells.
- Ensure that all devices to be installed are in a sheltered location and protected against the risk of accidental impact.
- Ensure that the operating temperature range as specified on the product dataplate is compatible with the climatic conditions of the place of installation.
- If the gate leaf incorporates a pedestrian access door or if this door is positioned in the gate movement area, ensure that this does not prevent normal gate travel; if necessary install a compatible interlock system.
- Connect the control unit to an electric power line equipped with an earthing system.
- On the power line from the automation, install a device for disconnection from the power mains, to guarantee a gap between contacts and complete disconnection in the conditions of overvoltage category III. If the power disconnect device is not in the vicinity of the automation, fit a block system against possible inadvertent or unauthorised connection.

3.3 - Product application limits

To ascertain suitability of the product with respect to the specific features of the gate and area to be automated, the following checks should be performed as well as a check for compliance of the technical data in this paragraph and the chapter 8 "**Product technical specifications**".

- Ensure that the dimensions and weight of the gate are within the following limits of use:

maximum length 7 m

maximum weight 500 kg

- Check the overall dimensions of the gearmotor with reference to **fig. 1**. *Note – These measurements also serve as a reference to calculate the space occupied by the foundation pit for routing the electrical cable ducting.*
- Ensure that the dimensions of the selected area for mounting the gearmotor is compatible with the overall dimensions.
- On the gate leaf, ensure that the surface for mounting the rack is suitable and solid.

Caution! – *If the results of these checks do not conform to specifications, this model cannot be used for automation of your gate.*

3.4 - Preliminary set-up work

Fig. 2, shows an example of an automation system set up with **Nice** components. These parts are positioned according to a typical standard layout.

With reference to **fig. 2**, locate the approximate position for installation of each component envisaged in the system.

Warning - the "fixed" control devices must be visible from the gate but positioned far from moving parts.

The gearmotor is factory set to be installed on the right-hand side of the gate. **CAUTION!** - *If forced to install the gearmotor on the left-hand side of the gate refer to the instructions in chapter 4 (paragraph 4.1 - point 07).*

Components required to set-up a complete system (fig. 2):

- 1 - electromechanical gearmotor
- 2 - pair of photocells
- 3 - key-operated selector switch or digital keypad
- 4 - flashing light with incorporated aerial
- 5 - limit switch brackets
- 6 - rack
- 7 - posts for photocells

Before starting installation, ensure that there is all equipment and materials required for the work concerned. Also ensure that all items are in good condition and comply with local safety standards.

Dig the routes for the ducting used for electrical cables, or alternatively external ducting can be laid, after which the pipelines can be

embedded in concrete and other preparation work for the installation can be completed to finalise the site ready for subsequent installation operations.

In particular, for digging the pit used to anchor the gearmotor to the ground, proceed as follows:

01. Dig the foundation pit in the gearmotor fixture point (**fig. 3**) **Note** – *The dimensions of the pit must be the same or greater than those of the foundation plate.*

02. Lay the ducting for the routing of cables.

CAUTION! – **In general, position the ends of the ducting used for electrical cables in the vicinity of the points envisaged for fixture of the various components.**

Note: *The ducting serves to protect electrical cables and prevent accidental damage in the event of impact.*

To prepare the electric cables required in the system, refer to **fig. 11-11a** and **Table 1 – Technical specifications of electric cables.**

TABLE 1: Technical specifications of electric cables

| Connection | Cable type | Maximum admissible length |
|---|---|--|
| A: POWER Cable | Cable 3 x 1,5 mm ² | 30 m (note 1) |
| B: FLASHING LIGHT with aerial cable | Cable 2 x 0,5 mm ² RG58 type shielded cable | 30 m 20 m (less than 5 m recommended) |
| C: PHOTOCELL Cable | Cable 2 x 0,5 mm ² (TX) Cable 4 x 0,25 mm ² (RX) | 30 m 30 m |
| D: KEY-OPERATED SELECTOR SWITCH cable DIGITAL KEYPAD | Cables 4 x 0,25 mm ² | 30 m |

General note: *The cables required for the set-up of the system (not included in the pack) may vary according to the quantity and type of devices envisaged for the installation.*

Note 1: *If greater lengths are required, a cable with a diameter of 3x2.5 mm² may be used; in this case earthing is required in the vicinity of the automation.*

CAUTION! – **The cables used must be suited to the installation environment; for example a cable type H03VV-F for indoor environments is recommended and a cable type H07RN-F for outdoor environments is recommended.**

3.5 - Installing the automation components

WARNINGS

- **Incorrect installation may cause serious physical injury to those working on or using the system.**
- **Before assembly of the automation, perform the preliminary checks as described in paragraphs "3.2 – Suitability of environment and gate to be automated" and "3.3 – Product application limits".**
- **Fit one or more sheaths for routing the electric cables.**

Fixing the foundation plate

IMPORTANT! – **If the weight of the gate exceeds 200 kg or if used in inadequate conditions, the foundation plate must be completely embedded in the concrete.**

There are two methods of anchoring the foundation plate to the ground:

- a) if a concrete base is already present:** Simply place the plate on the base in the correct position and secure by means of screws for concrete (**fig. 4**).
- b) if there is no concrete base:** Secure the plate in the concrete by means of the two bolts on the plate (**fig. 5**). To fix the plate, proceed as follows:

- 01.** Cast concrete into the pit, ensuring that the ducting tube for electric cables come out of the surface;
- 02.** While the concrete is still liquid, embed the foundation plate, ensuring that it protrudes from the concrete by its thickness.

Gearmotor installation

- 01.** Remove the gearmotor cover using a screwdriver to loosen the lateral screws (**fig. 6**). **Note** – *Leave the gearmotor without the cover until the installation and programming phases have been completed.*
- 02.** Place the gearmotor on the foundation plate and secure by means of the relative hex screw supplied (**fig. 7**).
- 03.** Release the gearmotor by means of the special release key (refer to the paragraph "Manually releasing or locking the gearmotor" in the "Operation manual").

04. Move the gate to the maximum opening position then position the first section of the rack above the pinion of the gearmotor (fig. 8). **Important:**- the total length of the rack must be the same as the length of the gate leaf; - the distance between the pinion and rack must be approx. 1-2 mm, to prevent the leaf weight from impairing gearmotor operation.
05. At this point fix the rack onto the leaf (refer to the rack instruction manual).
06. Manually slide the leaf to fix the other parts of the rack: Use the pinion as a reference point and a spirit level to position each section of the rack so that it is horizontal and perfectly aligned with the end placed on the pinion. **Note** – To provisionally fix the rack parts to the leaf, use the clamps as shown in fig. 9.
Warning – If the adjustment range possible with the rack is not sufficient, the gearmotor height can be adjusted by means of the 2 hex screws.
07. As the rack must not protrude from the gate leaf cut off any excess section as required.
08. Manually complete a number of Opening and Closing cycles to ensure that the rack slides smoothly along the pinion throughout the entire length. Also ensure that the distance between the pinion and rack is approx. 1-2 mm.
09. At this point tighten the 2 hex screws fully down.
10. Position (approximately) the two limit switch brackets on the rack (fig. 10) and manually move the gate for final fixture.
11. Fix the limit switch brackets as follows:
 - a) manually move the leaf to the opening position, leaving a distance of at least 2-3 cm from the mechanical end stop.
 - b) slide the travel limit bracket on the rack in the opening direction until the limit switch trips. Then move the bracket forward by at least 2 cm and lock on the rack using the grub screws supplied.
 - c) perform the same operation to secure the Closing limit switch.
12. Then lock the gearmotor by means of the special key (refer to the paragraph "Manually releasing or locking the gearmotor").

make the earthing connection on the terminal as shown in fig. 12.

Description of electrical connections

This section describes the possible connections to the control units for control devices and safety devices:

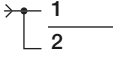
| Terminals | Function | Description |
|---|----------------|---|
| 1 - 2 - 3 | Power supply | Mains power line |
| 4 - 5 | Flashing light | Output for connection of flashing light to power mains (Max. 40 W) |
| 8 - 9 | 24 Vac | Service power supply 24 Vac +/- 25% (Max. 150 mA) |
| 9 | Common | Common for all inputs |
| 10 | Alt | Input with "Alt" function (Stop and brief inversion) |
| 11 | Foto | Input for safety devices |
| 12 | STEP-STEP | Input for sequential movement (SS) ("Open" – "Stop" – "Close" – "Stop") |
|  | 1 | Aerial + |
| | 2 | Aerial mass |

Warnings:

- The NC (normally closed) type contacts, if not used must be "jumped" and, if more than one, placed in SERIES;
- The NO (normally open) type contacts, if not used must be left free and, if more than one, placed in PARALLEL;
- The contacts must always be mechanical and free of any type of voltage; stage connections defined as "PNP", "NPN", "Open Collector" etc. are not admitted.

To connect the power cable to the control unit, proceed as shown in the fig. 13. The power cable must be fastened using the dedicated cable clamp as shown in point 13-3. **Note** – Some models of control unit may not have a transparent cover.

4.1 - Initial start-up and connection check

CAUTION! The following operations described in this manual will be performed on live electrical circuits and therefore manoeuvres may be hazardous! Therefore proceed with care.

4 ELECTRICAL CONNECTIONS

At this point after installing the gearmotor and control devices (key-operated selector switch or pushbutton panels) and safety devices (emergency stop, photocells, sensitive edges, flashing light) make electrical connections with reference to the following paragraphs and the example in fig.11-11a. The control unit has a series of functions selectable by means of dip-switches (mini switches) and settings made via trimmers (fig. 12). The input leds (fig. 12) indicate the operating status of the automation components, while the "OK" led (fig. 12), indicates correct operation of the control unit. The control unit incorporates a multicode radio receiver.

Control Unit components (fig. 12):

- a - Terminal board for aerial
- b - Function selection dipswitches
- c - Radio pushbutton
- d - Work Time setting trimmer (TL)
- e - Pause Time setting trimmer (TP)
- f - Control input/output terminal board
- g - Limit switch input connector
- h - Flashing light/ courtesy light output terminal board
- i - Capacitor connector
- l - Motor power supply output connector
- m - Power supply terminal board
- n - Radio indicator led
- o - Low voltage fuse (315 mA F)
- p - Force setting trimmer (F)
- q - "OK" Led
- r - Transformer
- s - Line fuse (5A F)

CAUTION!

- To avoid hazardous situations, ensure that the control unit is disconnected from the power supply during connections.
- Incorrect connections can cause faults or hazards; therefore ensure that the specified connections are strictly observed.
- There are precise standards regarding electrical safety and power-operated gates which must be strictly observed at all times.

Make all necessary connections with reference to the diagram in fig. 12 and the paragraph "Description of electrical connections".

To ensure correct electrical safety and optimal operation of the automation,

01. Power up the control unit and ensure that there is approx. 24 Vac between terminals 8 and 9.
02. Ensure that the "OK" led, after emitting some quick flashes, emits flashes at regular intervals.
03. At this point ensure that the leds related to inputs with NC contacts are lit (all safety devices active) and that the leds related to the NO inputs are off (no control present).
If this does not occur, check the various connections and functionality of the various devices. The Alt input is activated, deactivating the opening limit switch (FCA) and the closing limit switch (FCC).
04. Check the connection of the limit switches: Move the limit switch lever and ensure that the relative limit switch trips, switching off the corresponding led on the control unit.
05. Release the gearmotor and move the gate leaf to mid-travel and then lock the gearmotor. This ensures that the gate leaf is free to complete by opening and closing manoeuvres.
06. Ensure that the leaf moves in the correct direction according to the signal on the control unit. **Important** – This check is compulsory. If the leaf direction is not correct with respect to the signal on the control unit, the automation may apparently operate correctly (the "Open" cycle is the same as the "Close" cycle), but in practice the safety devices may be ignored during execution of the Closing manoeuvre. In this case, the safety devices would only be activated during the Opening manoeuvre, thus causing re-closure against the obstacle, with disastrous consequences!
07. Ensure that the direction of motor rotation is correct: Send a brief pulse signal to the SS input; the control unit always performs an Opening manoeuvre first and therefore simply ensure that also the motor moves in the direction of opening.
If this does not occur, proceed as follows:
 - a) disconnect control unit from the power supply;
 - b) rotate the motor power connector (l - fig. 12) and limit switch connector through 180° (g - fig. 12);
 - c) then power up the control unit and repeat the check from point 7.

The "OK" led on the control unit (fig. 12), serves to indicate the operating status of the latter:

- 1 regular flash every second = indicates that the internal microprocessor

is active and ready to receive commands.

- **1 quick double flash** = indicates when the microprocessor reads a variation in the operating status of an input (either of a control input or function dipswitch); this occurs then the detected variation does not have immediate effects.

- **1 very quick flash lasting 3 seconds** = indicates that the control unit has been powered up and is performing the test to check operating status.

- **1 flash at regular intervals** = indicates that the operating test has failed and that therefore a fault has been found.

5 PARAMETER SETTINGS

The control unit operating parameters can be adjusted by means of the trimmers (fig. 12) on the unit.

- **Work time (TL):** In Semi-automatic mode, this parameter sets the maximum duration of the *Opening* or *Closing* manoeuvre. To adjust this parameter, proceed as follows: **a)** select the "Semiautomatic" operating mode and position **Dip-Switch 1** at "ON"; **b)** position "Trimmer TL" to mid-travel; **c)** execute a complete *Opening* and *Closing* manoeuvre and check that the maximum duration set for the *Opening* and *Closing* manoeuvre is sufficient and that a margin of 2 or 3 seconds remains; if necessary repeat adjustment of "Trimmer TL" to set the maximum value. If the duration is still not sufficient, remove the jumper TLM in the vicinity of Trimmer TL (fig. 12), to obtain an "Extended Work Time" (TLM).

If the deceleration function is required, the trimmer must be set so that the deceleration phase starts at 50-70 cm before activation of the limit switches. Any modifications to this parameter are shown during the first *opening* manoeuvre following the modification.

- **Pause time (TP):** When set to "automatic" mode, this parameter sets the time that passes between the end of an *Opening* manoeuvre and the start of a *Closing* manoeuvre. To adjust this parameter, proceed as follows: **a)** select the "automatic" operating mode and position **Dip-Switch 2** at "ON"; **b)** position "Trimmer TP" as required; **c)** execute a complete *Opening* manoeuvre and check that the time that passes before the start of a *Closing* manoeuvre to ensure that the set time is correct.

- **Force (F): Caution** – Adjustment of this parameter has significant influence on the degree of automation safety and therefore great care must be taken during these procedures.

To adjust this parameter, proceed with a trial by error approach: Measure the force applied by the gate leaf during a manoeuvre and compare the reading with the values specified by local standards.

Operating mode

Step-step (SS): This mode, **used in manual mode (hold-to-run)**, activates the *Opening* and *Closing* manoeuvres alternately and when the command completes the manoeuvre it stops.

The manoeuvre is stopped, both on *Opening* and *Closing*, when limit switches are activated and also during *Closing* the movement is stopped if there is no permissive of the "Foto" safety devices. On the other hand, if "ALT" is activated, either in *Opening* or *Closing*, the manoeuvre is stopped immediately with a brief inversion.

When the manoeuvre is stopped, the delivery of the command must be interrupted by sending another command.

However, when Step Step mode is used in one of the **automatic modes ("Semiautomatic", "Automatic" or "Always Close")** delivery of a command activates the *Opening* and *Closing* manoeuvre alternately and a "Stop" function is activated when a second command is delivered. On the other hand, if "ALT" is activated, either in *Opening* or *Closing*, the manoeuvre is stopped immediately with a brief inversion.

In the case of automatic mode, there is a pause after an *Opening* manoeuvre, after which the *Closing* manoeuvre is performed.

During a pause, if the "Foto" safety devices are activated, the timer is reset with a new pause Time; otherwise if "Alt" is activated during the pause, the automatic closure function is cancelled and a Stop is activated.

During the *Opening* manoeuvre activation of a "Foto" device has no effect, while during closure this causes inversion of movement followed by a pause and then Closure.

Programmable functions

The control unit has a series of microswitches which enable activation of various functions to adapt the automation to the specific needs of the user and increase safety in the various conditions of use.

Dipswitch 1 or 2 is used to activate or deactivate the functions: To **activate** the dipswitch is set to "ON" and to **deactivate** it is set to "OFF".

Some of the functions available regard safety, and it is therefore important to carefully evaluate which function is the safest.

The dipswitches enable selection of the various operating modes and programming of the required functions, as described in **Table A:**

Table A

| | | |
|--------------------|----------------|---|
| Switch 1-2: | Off-Off | Manual movement, <i>i.e. hold-to-run</i> |
| | On-Off | Semi-automatic movement |
| | Off-On | "Automatic" movement, <i>i.e. automatic closure</i> |
| | On-On | "Automatic" movement, + "Always Close" |
| Switch 3: | On | Apartment block mode (<i>not available in manual mode</i>) |
| Switch 4: | On | pre-flash |
| Switch 5: | On | Re-close 5 seconds after "Foto" if set to "Automatic" or "Close after Foto" if set to "Semiautomatic" |
| Switch 6: | On | "Foto" safety also on <i>Opening</i> |
| Switch 7: | On | Gradual start-up |
| Switch 8: | On | Deceleration |
| Switch 9: | On | Brake |
| Switch 10: | On | Not used |

Switch 1-2

In "Manual" mode, the manoeuvre is executed exclusively while the command is present (while the transmitter key is held down -hold-to-run).

In "Semi-automatic" mode, on delivery of a command the manoeuvre is executed exclusively until the Work Time elapses or when the limit switch is reached.

In the case of "automatic" mode, there is a pause after an *Opening* manoeuvre, after which the *Closing* manoeuvre is performed.

The "Always Close" function is activated following a power failure; when power is restored, if the control unit detects the gate leaf in the *Opening* position, it automatically starts a *Closing* manoeuvre preceded by a 5-second pre-flash interval.

Switch 3

In **Apartment Block mode**, when a Step-Step command is sent and an *Opening* manoeuvre is started, this cannot be interrupted by any other "Step-Step command or "Open" command via radio until the manoeuvre is completed.

However, during the *Closing* manoeuvre, delivery of a Step-Step command causes shutdown of the manoeuvre and immediate inversion of movement.

Switch 4

When a command is sent, the flashing light is activated first, and after 5 seconds (2 seconds if set to Manual mode) the manoeuvre is started.

Switch 5

This function, if set to "Automatic" mode enables the user to keep the gate leaf open only for the time required for transit of vehicles or persons; in fact after activation of the "Foto" safety devices, the manoeuvre is topped and after 5 seconds a *Closing* manoeuvre is started automatically.

However, if "Semi-automatic" mode is set, when the "Foto" safety devices are activated, during a *Closing* manoeuvre automatic closure is activated with a duration as set in the "Pause Time".

Switch 6

The "Foto" safety function is normally activated only for *Closing* manoeuvres; if Dipswitch 6 is set to ON activation of the safety device also causes interruption of the manoeuvre in *Opening*. On the other hand, if "Semiautomatic" or "automatic" mode is set, the *Opening* manoeuvre is resumed immediately after the safety devices are released.

Switch 7

When this function is set, the manoeuvre is started up gradually; this avoids possible jerks in movement of the automation.

Switch 8

Deceleration consists in a 30% reduction of the nominal speed, to reduce the impact force at the end of a manoeuvre.

Once the deceleration function is enabled, the Work Time (WT) must be adjusted as the deceleration start depends on the set Work Time. Therefore the TL must be set so that the deceleration phase starts at 50-70 cm before activation of the limit switches.

The deceleration function slows down the automation speed and reduces motor torque by 70%. **CAUTION** – On automations requiring a high motor torque, this deceleration function may cause immediate shutdown of the motor.

Switch 9

When this function is set, a motor braking procedure is performed at the end of a manoeuvre, initially at a moderate level and then stronger in order to quickly stop the gate leaf without jerking movements.

Switch 10

Not used.

• Installing an external aerial

If the aerial supplied is not in an optimal position and the radio signal is too weak, the installation of an external aerial is recommended (mod. ABF or ABFKIT). The new aerial must be placed as high as possible above any metal or reinforced concrete structures present in the area.

• Connection to the control unit

To connect the receiver to the control unit, use a coaxial cable with an impedance of 50 Ohm (e.g. RG58 cable with low voltage drops). **Caution!**– To reduce signal dispersion, use a short cable (do not exceed 10 m).

WARNINGS for programming

• Programming operations in this chapter require use of key “c” and the Led “n” (fig. 12) present on the receiver. The Led, indicates the status of operations in progress, emitting a specific number of flashes of a set duration. Table C describes the meanings of the flashes.

• Always read the **procedure first** and **then perform the operations in the correct sequence**.

CAUTION!– Before memorising a transmitter, carefully read the following section.

The receiver can only memorise the transmitters belonging to one of the following 3 encoding families:

- families consisting of “O-Code”, “FloR” and “TTS” encoding;
- family consisting of “Flo” encoding;
- family consisting of “Smilo” encoding.

Note – On the receiver, each code enables use only of the functions specific to that type of encoding.

Caution!– The encoding family of the first transmitter memorised on the receiver also defines the family to which the following memorised transmitters must belong.

To modify the encoding family on the receiver, the procedure “Total deletion of receiver memory” must be performed.

To verify whether the transmitters are already memorised on the receiver and the relative encoding family, proceed as follows:

01. Disconnect the receiver electric power supply.
02. Restore the receiver power supply and count the number of green flashes emitted by the receiver led.
03. Then compare the number of flashes counted with the values in the table below:
 - 1 flash = Flo encoding
 - 2 flashes = O-Code / FloR / TTS encoding
 - 3 flashes = Smilo encoding
 - 5 flashes = no transmitter entered

Caution! – Before starting the transmitter memorisation procedure, carefully read all memorisation procedures described below to select the most suitable method.

6.1 - Transmitter memorisation modes: “Mode I” and “Mode II”

In general, the combination of these commands and keys on a transmitter can be made in two ways:

• **Mode I:** This mode enables memorisation of all transmitters keys or just a group of the latter on the receiver in a single process (only on transmitters with more than one identity code, such as ON9 models). In this mode the transmitter codes are automatically associated with the commands pre-set on the control unit.

• **Mode II:** This mode enables memorisation of a single transmitter key on the receiver. The user can select which command to be programmed from those available on the control unit (maximum 4).

“Mode I” memorisation procedure

Warning – This procedure memorises all transmitter keys or one group of keys at the same time.

01. Press and hold the receiver key until the **green** led illuminates on the receiver. Then release the key.
02. Within 10 seconds, press and hold any key on the transmitter to be memorised, until the led on the receiver emits the first of 3 green flashes to confirm memorisation.

Note – At the end of the 3 flashes, there are an additional 10 seconds to memorise other transmitters.

“Mode II” memorisation procedure

Warning – The procedure memorises a single key of the transmitter.

Therefore the programming procedure must be repeated for each transmitter key to be memorised.

01. Refer to the “Controls Table” to select the commands available; select the command to assign to the transmitter key to be memorised and then note the number corresponding to the command.
02. On the receiver, press the key the same number of times as the number of the command (previously noted) and the receiver led emits the same number of repeated flashes.
03. (on the transmitter, within 10 seconds), press and hold the transmitter key to be memorised, until the led on the receiver emits the first of 3 green flashes to confirm memorisation.

Note – After the 3 flashes, there are an additional 10 seconds to memorise the same command on other keys of the same transmitter or a new transmitter.

Controls table

Output 1 = **STEP STEP**

Output 2 = **ALT**

Output 3 = **OPEN**

Output 4 = **CLOSE**

6.2 - Memorisation of a new transmitter with procedure in the vicinity of the receiver [a transmitter already memorised must be available]

A NEW transmitter can be memorised in the receiver memory without acting directly on key of the receiver, but by simply working within its reception range. To use this procedure, an OLD transmitter, previously memorised (in Mode I or Mode II) and operative, is required. The procedure enables the NEW transmitter to receive the settings of the OLD version.

Warnings:

- **Warning** – The procedure must be performed within the reception range of the receiver (10-20 m from receiver).
- Therefore the programming procedure must be repeated for each transmitter key to be memorised.

One of the following procedures can be used, as required:

Standard procedure

01. On the NEW transmitter, press and hold the key ** for at least 5 seconds (**note 1**) and then release.
02. On the OLD transmitter press the key ** three times (**note 2**) and then release.
03. On the NEW transmitter, press the same key pressed in point 01 once and then release.

Alternative procedure

01. On the NEW transmitter, press and hold the key ** for at least 3 seconds... (**note 1**) and then release.
02. On the OLD transmitter, press and hold the key ** for at least 3 seconds... (**note 2**) and then release.
03. On the NEW transmitter, press and hold the same key pressed in point 01 for at least 3 seconds and then release.
04. On the OLD transmitter, press and hold the same key pressed in point 02 for at least 3 seconds until the green led L1 on the receiver emits 3 flashes to confirm memorisation.

Note 1 – Press any key, if the OLD transmitter is memorised in “Mode I” or press the key to be memorised if the OLD transmitter is memorised in “Mode II”.

Note 2 – Press any key, if this transmitter is memorised in “Mode I” or press the key with the command to be transferred, if this transmitter is memorised in “Mode II”.

6.3 - Total deletion of receiver memory

To delete all memorised transmitters from the receiver memory, or all data stored, proceed as follows:

01. Press and hold the receiver key until the **green** led illuminates and check the variations in led status:
 - after approx. 4 seconds, the green led illuminates;
 - then, after approx. 4 seconds, the green led turns off;
 - lastly, after approx. 4 seconds, the green led starts flashing.
02. At this point, to delete all transmitters release the key **precisely on the 3rd flash** of the green led; otherwise to delete the entire memory of the receiver (including configurations and transmitter encoding family) release the key **precisely on the 5th flash** of the green led.

CAUTION! – All operations in this chapter must be performed exclusively by skilled and qualified personnel, in observance of the instructions in the manual, and current local legislation and safety standards in the place of installation.

These are the most important phases of automation set-up to ensure maximum system safety. The testing procedure described can also be performed as a periodic check of automation devices.

Testing and commissioning of the automation must be performed by skilled and qualified personnel, who are responsible for the tests required to verify the solutions adopted according to the risks present, and for ensuring observance of all legal provisions, standards and regulations: and in particular all requirements of the standard EN 12445, which establishes the test methods for checking automations for gates.

7.1 - Automation testing

Each automation component, such as sensitive edges, photocells, emergency stop, etc., requires a specific testing phase; for these devices take care to follow the procedures specified in the respective instruction manual. To test, proceed as follows:

- 1 Ensure that all specifications in the chapter "GENERAL SAFETY PRECAUTIONS AND WARNINGS" regarding safety have been strictly observed;
- 2 Release the gearmotor by means of the special release key (refer to the paragraph "Manually releasing or locking the gearmotor" in the "Operation manual");
- 3 Ensure that the gate leaf can be moved manually both in opening and closing;
- 4 Then lock the gearmotor by means of the special key (refer to the paragraph "Manually releasing or locking the gearmotor");
- 5 Using the control or stop devices of the automation (key-operated selector switch, control pushbuttons, transmitters, etc.) perform gate opening and closing tests, ensuring that the leaf movement corresponds to specifications. Test several times to assess smooth operation of the gate and check for any defects in assembly or adjustment and any possible points of friction;
- 6 Check operation of all system safety devices one at a time (photocells, sensitive edges, etc.) and ensure that automation behaviour corresponds to specifications. Each time a safety device is activated, the OK led on the control unit must emit 2 quick flashes, to confirm acknowledgement of the event by the control unit;
- 7 Measure the impact force as specified in the standard EN 12445. If the motor force control is used by the control unit as an auxiliary function for reduction of impact force, adjust the functions to identify the setting that obtains the best results;
- 8 Permanently affix a label in the zone adjacent to the automation describing how to manually release the gearmotor.

7.2 - Automation commissioning

Commissioning can only be performed after positive results of all test phases. Partial or "makeshift" commissioning is strictly prohibited.

- 1 Prepare the automation technical documentation (to be conserved for at least 10 years), which must contain the following documents: an overall layout diagram of the automation, electrical wiring diagram, risk assessment and relative solutions adopted, manufacturer's declaration of conformity for all devices used and the declaration of conformity compiled by the installer, copy of instruction manual for operation and the automation maintenance schedule;
- 2 Affix a dataplate on the door, specifying at least the following data: type of automation, name and address of manufacturer (responsible for commissioning), serial number, year of construction and CE mark;
- 3 Prepare and provide the automation owner with the declaration of conformity; the form "**CE Declaration of conformity**" must be compiled for this purpose;
- 4 Prepare and provide the automation owner with the form "**Operation manual**";
- 5 Prepare and provide the owner with the form "**Maintenance schedule**", containing all maintenance instructions for all devices in the automation;
- 6 Before commissioning the automation, ensure that the owner is adequately informed of all associated risks and hazards.

PRODUCT DISPOSAL

This product is an integral part of the automation and therefore must be disposed together with the latter.

As in installation, also at the end of product lifetime, the disassembly and scrapping operations must be performed by qualified personnel.

This product comprises various types of materials: some may be recycled others must be disposed of. Seek information on the recycling and disposal systems envisaged by the local regulations in your area for this product category.

CAUTION! – some parts of the product may contain pollutant or hazardous substances which, if disposed of into the environment, may cause serious damage to the environment or physical health.

As indicated by the symbol alongside, disposal of this product in domestic waste is strictly prohibited. Separate the waste into categories for disposal, according to the methods envisaged by current legislation in your area, or return the product to the retailer when purchasing a new version.



CAUTION! – Local legislation may envisage serious fines in the event of abusive disposal of this product.

PERIODIC MAINTENANCE OPERATIONS

In general, this product does not require special maintenance; however, regular checks over time will ensure system efficiency and correct operation of the safety systems installed

The automation requires periodic maintenance to ensure optimal operation, extended lifetime and complete safety. Automation maintenance must be scheduled at regular intervals. Scheduled routine maintenance must be performed at the latest every 6 months.

To perform maintenance checks, proceed as follows.

CAUTION! - **Disconnect all electric power sources before performing any checks.**

- Check all automation components for wear; with special attention to the phenomena of erosion or oxidation of structural parts; if necessary replace parts that show reduced efficiency.
- Check the moving parts for wear: Pinion, rack, and all parts making up the gate leaf; replace worn parts as necessary.
- On completion of the maintenance checks, reconnect the electric power supply and perform all tests and checks as envisaged in chapter 4.

TECHNICAL SPECIFICATIONS OF PRODUCT

| | |
|--|---|
| ■ Mains power supply | 230 Vac 50 Hz |
| ■ Motor | Asynchronous-single phase |
| ■ Limit switch type | Electromechanical |
| ■ Max. power absorption | 400 W |
| ■ Line Absorption | 1.7 A |
| ■ Built-in capacitor | 12 nF |
| ■ Protection rating | IP 44 |
| ■ Maximum torque (corresponding to force) | 15 Nm (500 N) |
| ■ Nominal torque (corresponding to force) | 8 Nm (270 N) |
| ■ Nominal speed | 0.18 m/s |
| ■ Thermal protection | 140 °C |
| ■ Maximum leaf weight | 500 Kg |
| ■ Maximum leaf length | 7 m |
| ■ Max. No. Cycles per hour | 9 (leaf 7 metres) |
| ■ Max. No. consecutive Cycles | 5 |
| ■ Dimensions | 290 x 195 x h 250 mm |
| ■ Weight | 8 Kg |
| ■ Max. Service current 24 V | 150 mA (voltage can vary by $\pm 25\%$) |
| ■ Flashing light output | For connection of flashing light to power mains (Max. power 40 W) |
| ■ Operating temperature | From -20 °C to +50 °C |
| ■ Work time | Adjustable from 2.5 to > 40 s., or from < 40 to > 80 s. with TLM |
| ■ Pause time | Adjustable from 5 to > 80 s. |
| ■ Decoding | “O-Code” / “FloR” / “TTS”; or Flo”; or “Smilo” |
| ■ Reception frequency | 433.92 MHz |
| ■ Sensitivity | Better than 0.5 V |
| ■ Operating temperature | from -20 to +55° C |
| ■ Input impedance | 52 ohm |

OPERATION MANUAL

(to deliver to the automation user)

IMPORTANT – This instruction sheet contains important information regarding safety; take care to read all instructions before using the product. Keep this manual in a safe place to enable future use.

SAFETY WARNINGS AND PRECAUTIONS

NEVER touch parts of the automation while the gate is moving!

- Before using the automation for the first time, take care to read this operation manual provided by the automation installer. Also ensure that you are fully informed of all origins of residual risks.

- Keep the manual for consultation when in doubt and ensure supply to new owners of the automation.

- Your automation is a machine that performs commands imparted by the user; negligent or improper use may constitute a hazard. Never activate automation controls if persons, animals or objects are present in the operating range.

- **Children:** this automation system guarantees a high level of safety, using special detection devices to prevent movement in the presence of persons or objects . thereby guaranteeing constant foreseeable and safe activation. However, it is advisable to ensure that children do not play in the vicinity of the automation. To avoid inadvertent activation, and remote controls should always be kept out of reach. (the transmitter is not a toy!).

- Check the automation frequently to detect possible imbalance, signs of wear or damage. Suspend use immediately if maintenance is required.

- Periodically check correct operation of the photocells and perform the scheduled maintenance at least every six months.

- Photocells do not constitute actual safety devices, but safety aids. They are designed using highly reliable technology, but in extreme conditions may be subject to malfunctions or potential faults. **CAUTION!**– In certain cases these faults are not immediately evident.

Never pass the transit area while the gate is moving!

- If any anomalous condition is noted on the automation, disconnect the power supply from the system immediately. Never attempt to repair the automation alone; contact your local installer for assistance. In the meantime the system can be used with manual Opening and Closing by manually releasing the gearmotors as described in this manual.

- In the event of a power failure, on restoral of power the first manoeuvre command will be executed at low speed, regardless of the type of speed set.

- Even if you possess the skills, never modify the system or automation programming and adjustment parameters: This is the responsibility of the automation installer.

- Testing, periodic maintenance and any repairs must be documented by the person performing the operations and the relative documents must be kept by the system owner.

- At the end of the automation's lifetime, ensure that it is disposed by qualified personnel and that the materials are recycled or scrapped according to current standards in the place of use.

MANUALLY RELEASING OR LOCKING THE GEARMOTOR

The gearmotor is equipped with a mechanical system that enables manual opening and closing of the gate.

These manual operations must be performed in the event of a power failure or system malfunctions. In the latter case, use of the release mechanism may be useful also to check whether the fault is linked to the mechanism itself (e.g. it may be incorrectly tightened).

To manually release the gearmotor, use the release key supplied as follows:

- 01.** Slide the lock cover backwards;
- 02.** Insert the key in the relative release pin;
- 03.** Turn the key clockwise through 90° and pull the handle towards you;

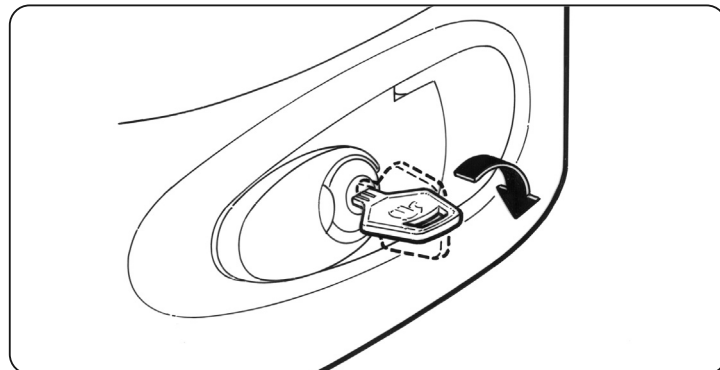

- 04.** At this point the gate leaf can be moved manually to the required position.

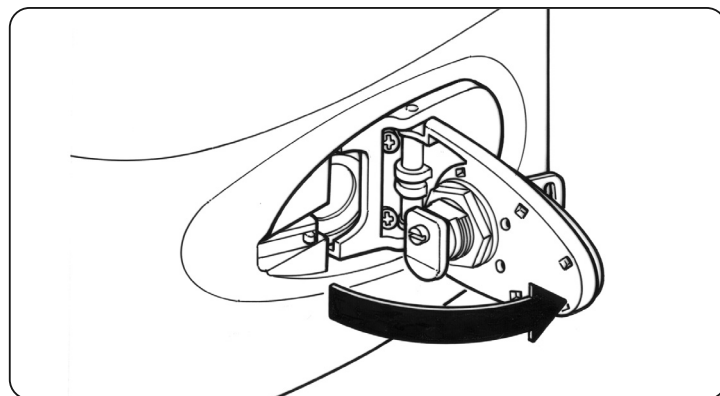

- 05.** To restore normal automation operation, close the handle, turn the key anti-clockwise on the release pin and manually move the gate leaf until you hear the leaf engage mechanically with the drive mechanism.
- 06.** Then remove the key from the release pin and store in a safe place.



CE DECLARATION OF CONFORMITY

Note: The contents of this declaration correspond to those of the official document, deposited at the registered offices of Nice S.p.a., and in particular to the last revision available before printing of this manual. The text herein has been drawn up for editorial purposes.

A copy of the original declaration can be requested from Nice S.p.a. (TV) I.

Number: 287/RO500

Revision: 0

The undersigned, Luigi Paro, in the role of Managing Director, declares under his sole responsibility, that the product:

Manufacturer's Name: NICE s.p.a.

Address: Via Pezza Alta 13, Z.I. Rustignè, 31046 Oderzo (TV) Italy

Type: 230 V ac electromechanical gearmotor with built-in control unit

Models: RO500

Accessories: Radio control series FLO, FLOR, Smilo, Opera

Comply with the requirements of the EC directive:

• 98/37/EC (89/392/EEC amended); DIRECTIVE 98/37/EC OF THE EUROPEAN PARLIAMENT AND COUNCIL of 22 June 1998 regarding the approximation of member state legislation related to machinery.

As envisaged in the directive 98/37/EC, start-up of the product specified above is not admitted unless the machine, in which the product is incorporated, has been identified and declared as conforming to directive 98/37/EC.

The product also conforms to the essential requirements stated in article 3 of the following EC directive, for the intended use of products:

• 1999/5/EC; DIRECTIVE 1999/5/EC OF THE EUROPEAN PARLIAMENT AND COUNCIL of 9 March 1999 regarding radio equipment and telecommunications terminal equipment and the mutual recognition of their conformity.

According to the following harmonised standards

health protection standards: EN 50371:2002;

Electric safety: EN 60950-1:2006;

Electromagnetic compatibility: EN 301 489-1V1.8.1:2008;

EN 301 489-3V1.4.1:2002

Radio spectrum: EN 300220-2V2.1.2:2007

The product also complies with the requirements of the following EC directives:

• 2006/95/EEC (ex directive 73/23/EC), DIRECTIVE 2006/95/EC OF THE EUROPEAN COUNCIL of 12 December 2006 regarding the approximation of member state legislation related to electrical material destined for use within specific voltage limits.

according to following harmonised standard:

EN 60335-1:1994+A11:1995+A1:1996+A12:1996+A13:1998+A14:1998+A15:2000+A2:2000+A16:2001

• 2004/108/EEC (ex directive 89/336/EC), DIRECTIVE 2004/108/EC OF THE EUROPEAN COUNCIL of 15 December 2004 regarding the approximation of member state legislation related to electromagnetic compatibility, and repealing directive 89/336/EEC.

According to the following harmonised standards:

EN 61000-6-2:2005; EN 61000-6-3:2007

The product also complies, within the constraints of applicable parts, with the following standards:

EN 60335-1:2002+A1:2004+A11:2004+A12:2006+ A2:2006,

EN 60335-2-103:2003,

EN 13241-1:2003; EN 12453:2002; EN 12445:2002; EN 12978:2003

Oderzo, 20 May 2009

Luigi Paro
(Managing director)



DICHIARAZIONE CE DI CONFORMITÀ

Nota: Il contenuto di questa dichiarazione corrisponde a quanto dichiarato nel documento ufficiale depositato presso la sede di Nice S.p.a., e in particolare, alla sua ultima revisione disponibile prima della stampa di questo manuale. Il testo qui presente è stato riadattato per motivi editoriali.

Copia della dichiarazione originale può essere richiesta a Nice S.p.a. (TV) I.

Numero: 287/RO500

Revisione: 0

Il sottoscritto Luigi Paro in qualità di Amministratore Delegato, dichiara sotto la propria responsabilità che il prodotto:

Nome produttore: NICE s.p.a.

Indirizzo: Via Pezza Alta 13, Z.I. Rustignè, 31046 Oderzo (TV) Italia

Tipò: Motoriduttore elettromeccanico 230Va.c. con centrale incorporata

Modelli: RO500

Accessori: Radiocomandi serie FLO, FLOR, Smilo, Opera

Risulta conforme a quanto previsto dalla direttiva comunitaria:

• 98/37/CE (89/392/CEE modificata) DIRETTIVA 98/37/CE DEL PARLAMENTO EUROPEO E DEL CONSIGLIO del 22 giugno 1998 concernente il ravvicinamento delle legislazioni degli Stati membri relative alle macchine.

Come previsto dalla direttiva 98/37/CE si avverte che non è consentita la messa in servizio del prodotto sopra indicato finché la macchina, in cui il prodotto è incorporato, non sia stata identificata e dichiarata conforme alla direttiva 98/37/CE.

Inoltre risulta conforme ai requisiti essenziali richiesti dall'articolo 3 dalla seguente direttiva comunitaria, per l'uso al quale i prodotti sono destinati:

• 1999/5/CE DIRETTIVA 1999/5/CE DEL PARLAMENTO EUROPEO E DEL CONSIGLIO del 9 marzo 1999 riguardante le apparecchiature radio e le apparecchiature terminali di telecomunicazione e il reciproco riconoscimento della loro conformità.

Secondo le seguenti norme armonizzate

protezione della salute: EN 50371:2002;

sicurezza elettrica: EN 60950-1:2006;

compatibilità elettromagnetica: EN 301 489-1V1.8.1:2008;

EN 301 489-3V1.4.1:2002

spettro radio: EN 300220-2V2.1.2:2007

Inoltre il prodotto risulta conforme a quanto previsto dalle seguenti direttive comunitarie:

• 2006/95/CEE(ex direttiva 73/23/CE) DIRETTIVA 2006/95/CE DEL PARLAMENTO EUROPEO E DEL CONSIGLIO del 12 dicembre 2006 concernente il ravvicinamento delle legislazioni degli Stati membri relative al materiale elettrico destinato ad essere adoperato entro taluni limiti di tensione.

Secondo la seguente norma armonizzata:

EN 60335-1:1994+A11:1995+A1:1996+A12:1996+A13:1998+A14:1998+A15:2000+A2:2000+A16:2001

• 2004/108/CEE(ex direttiva 89/336/CEE) DIRETTIVA 2004/108/CE DEL PARLAMENTO EUROPEO E DEL CONSIGLIO del 15 dicembre 2004 concernente il ravvicinamento delle legislazioni degli Stati membri relative alla compatibilità elettromagnetica e che abroga la direttiva 89/336/CEE.

Secondo le seguenti norme armonizzate: EN 61000-6-2:2005;

EN 61000-6-3:2007

Inoltre risulta conforme, limitatamente per le parti applicabili, alle seguenti norme:

EN 60335-1:2002+A1:2004+A11:2004+A12:2006+ A2:2006,

EN 60335-2-103:2003, EN 13241-1:2003; EN 12453:2002;

EN 12445:2002; EN 12978:2003

Oderzo, 20 maggio 2009

Luigi Paro
(Amministratore Delegato)



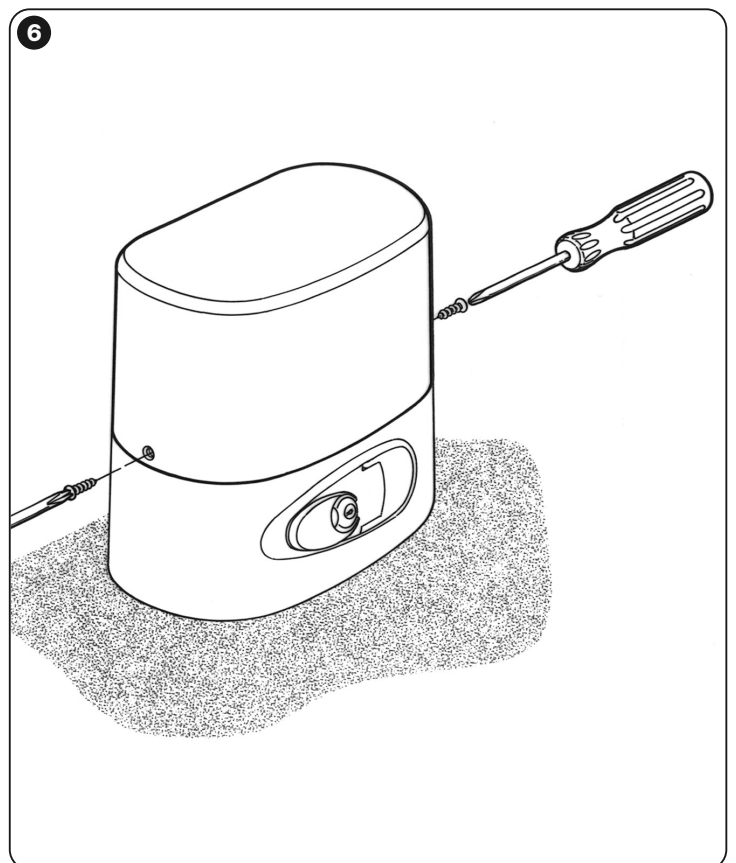
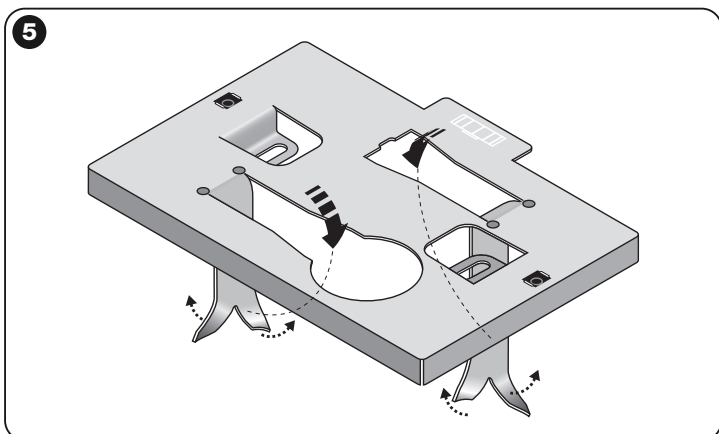
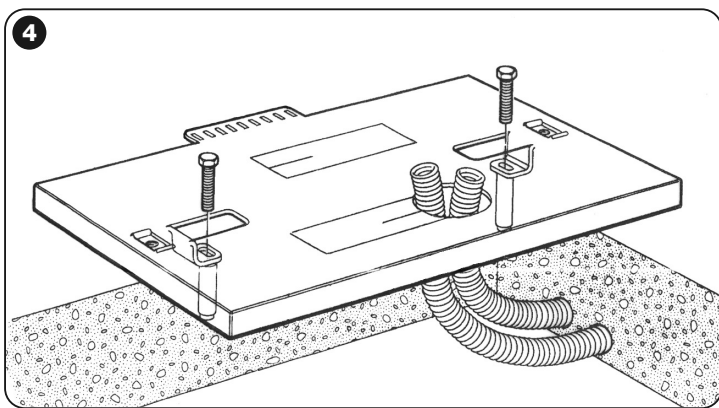
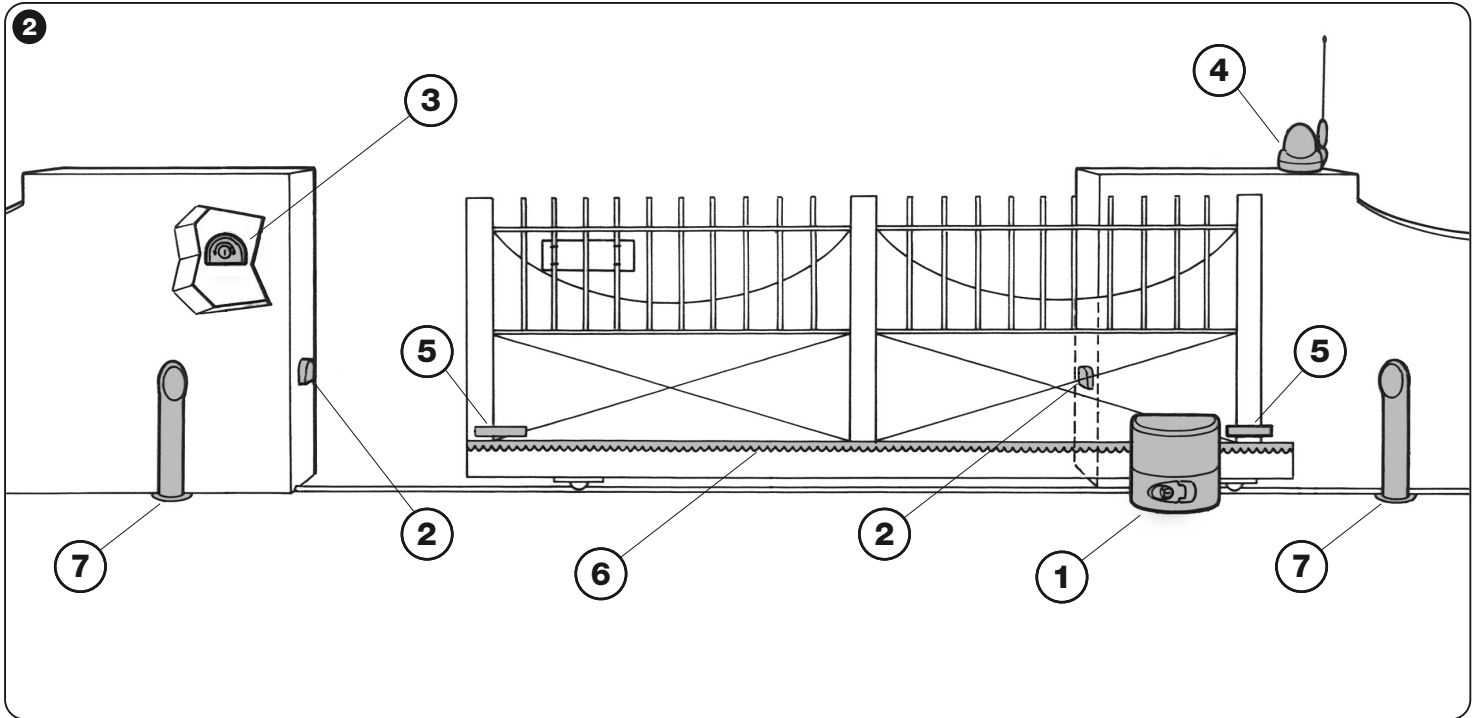
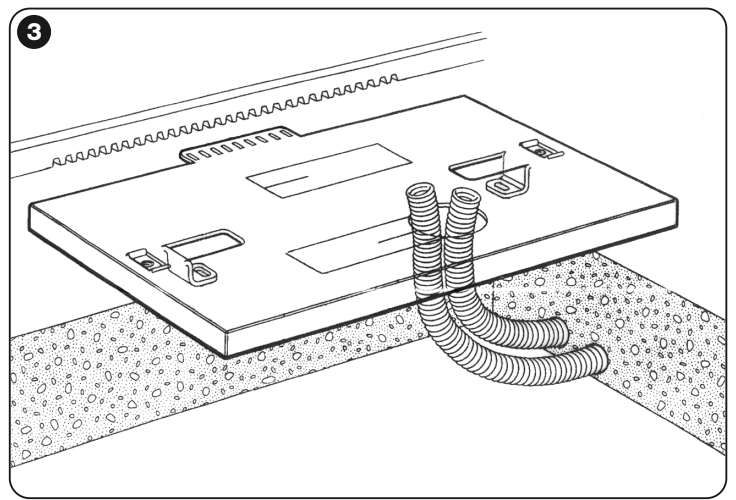
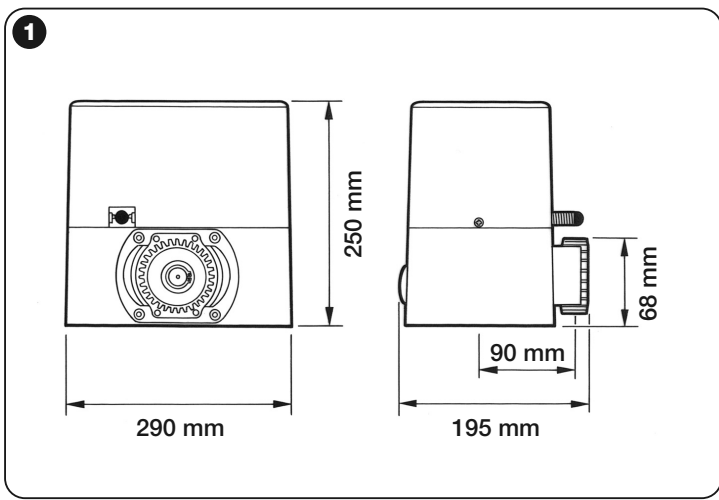

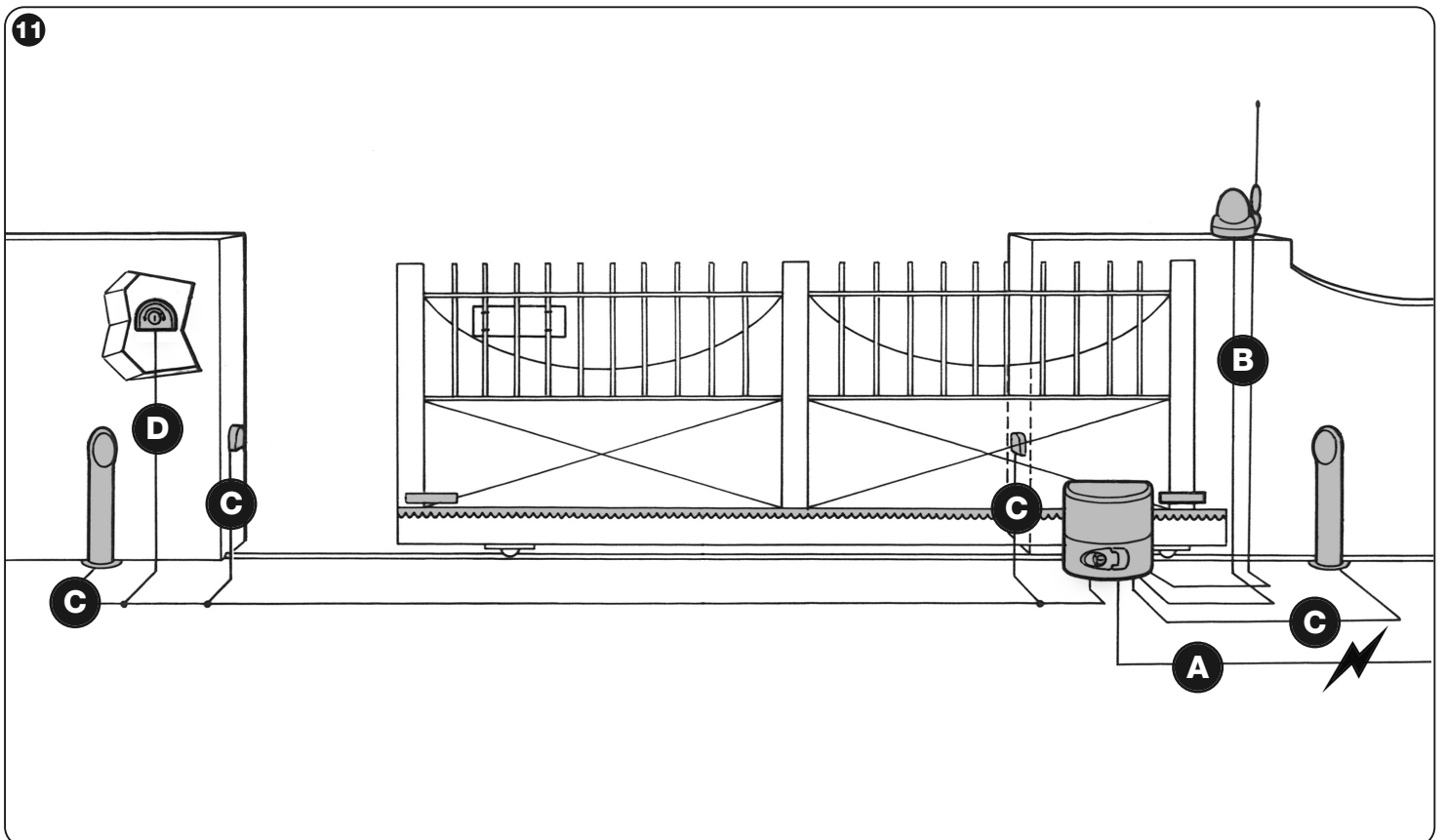
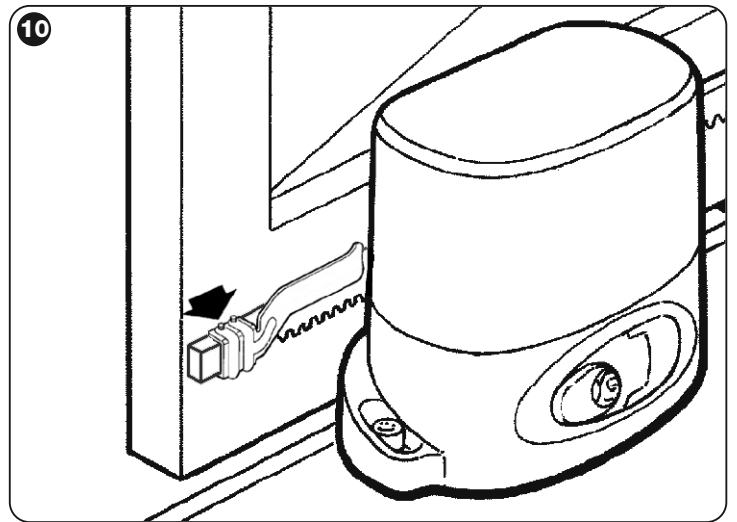
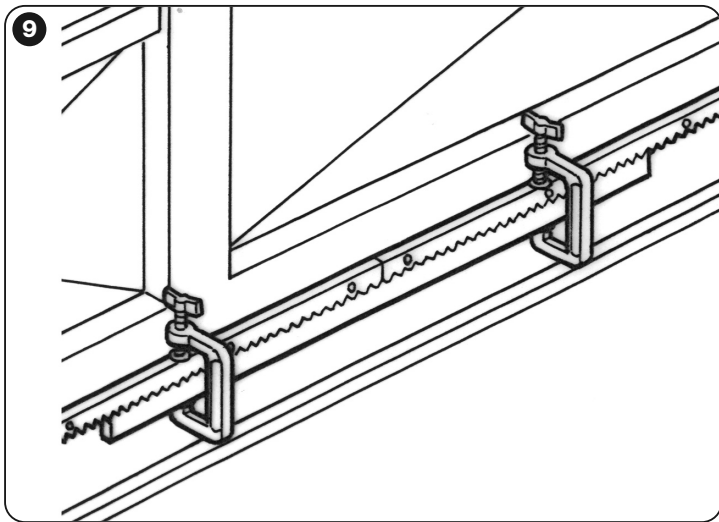
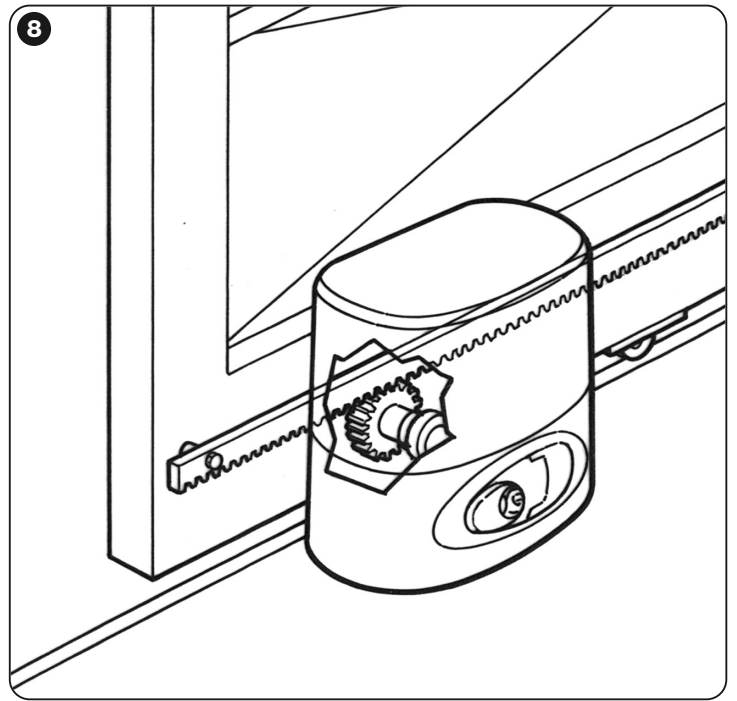
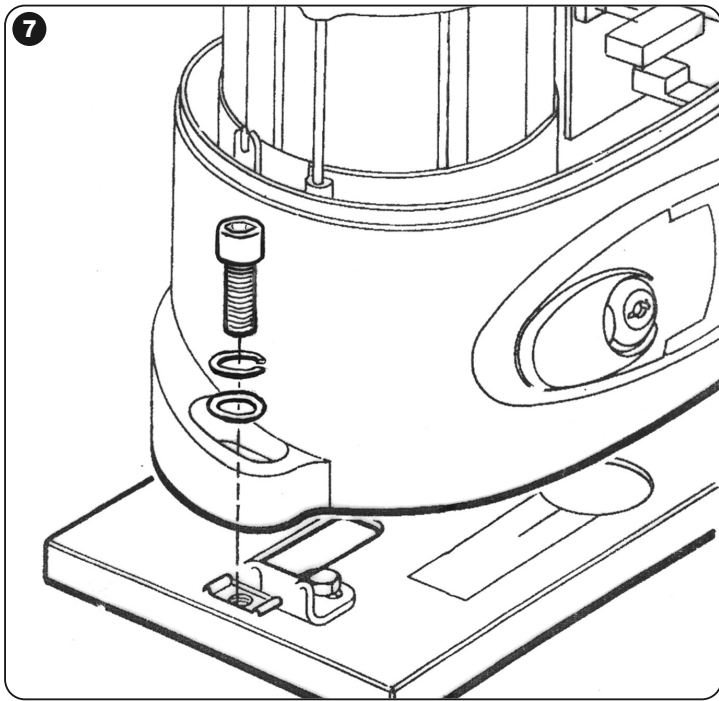

11a

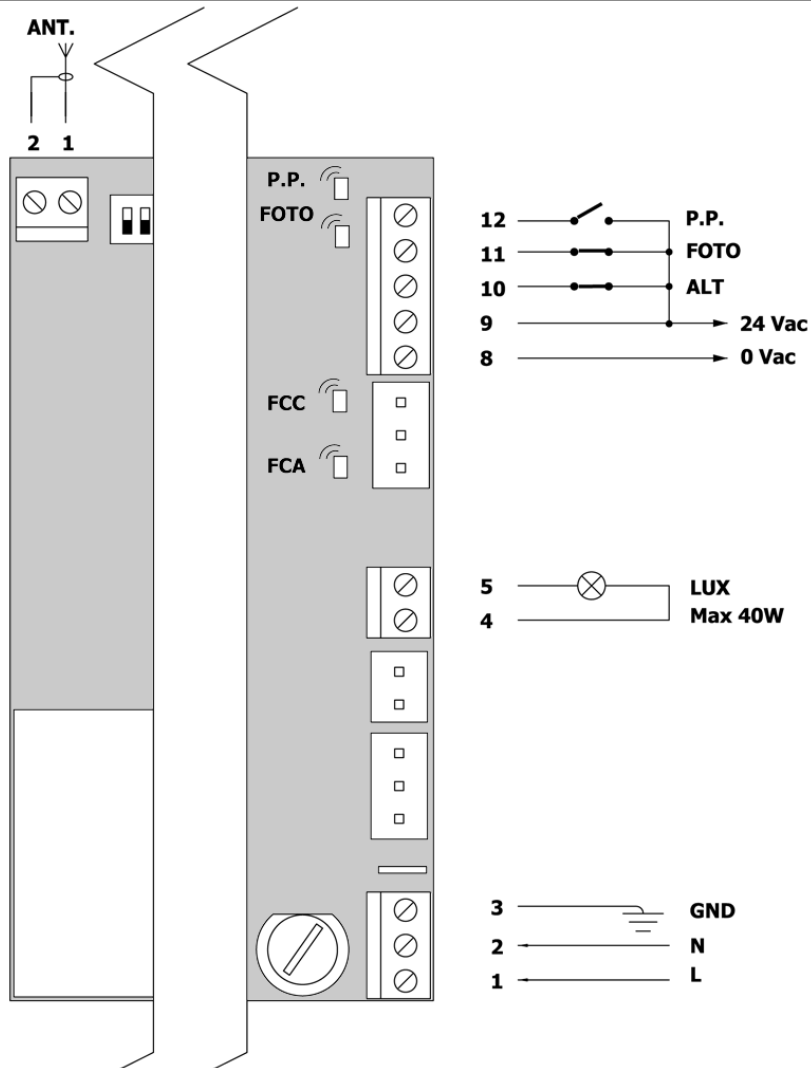

12

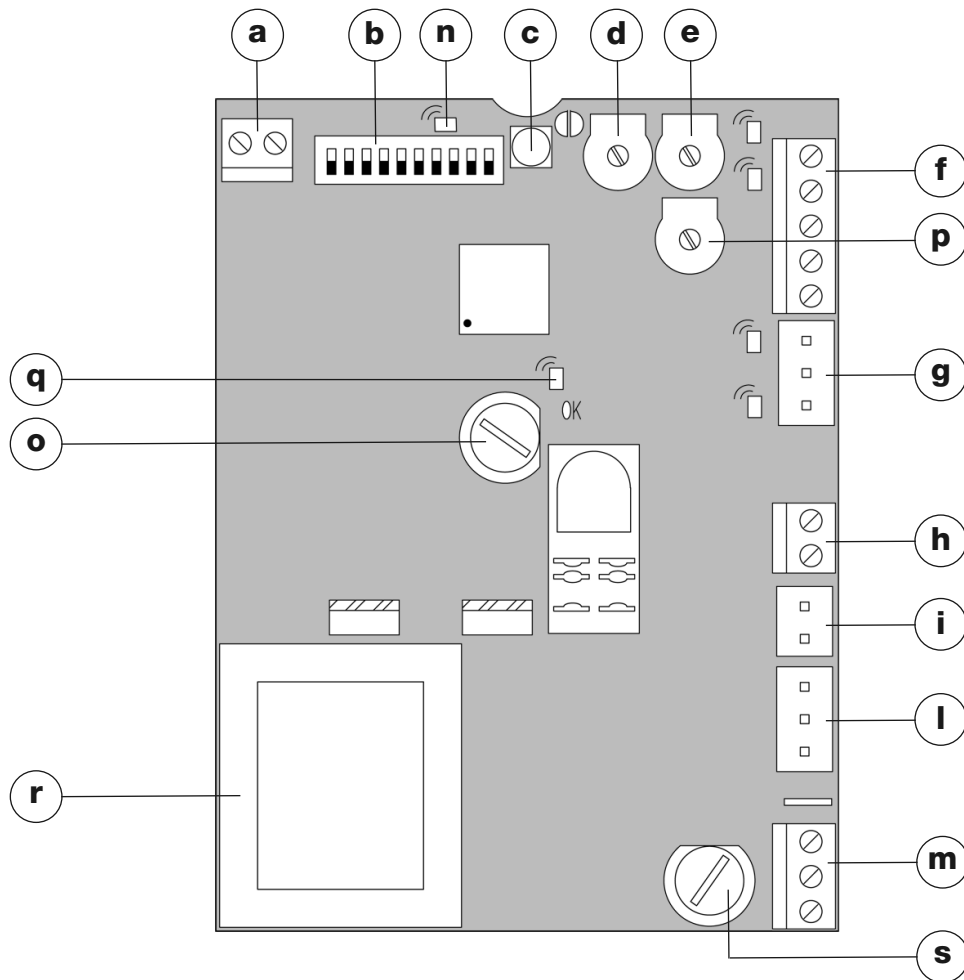

1

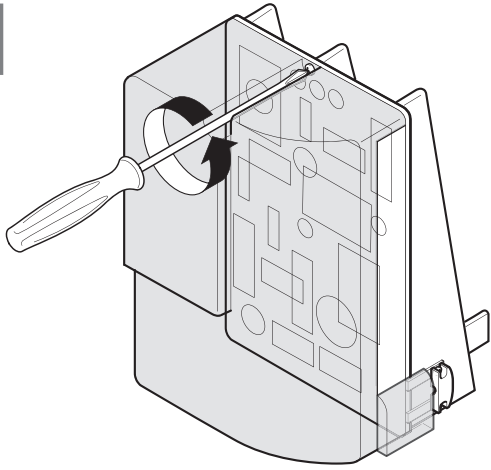

2

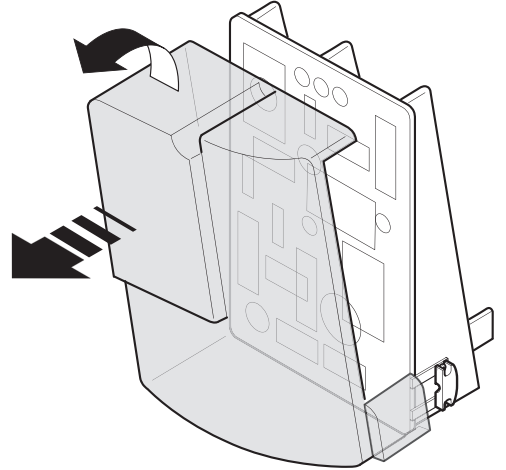

3

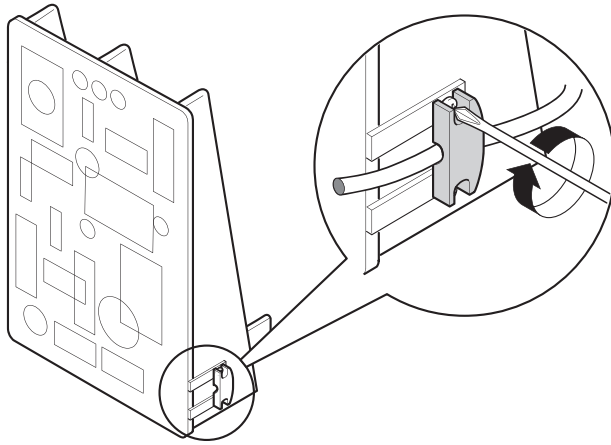



Nice

Headquarters

Nice SpA

Oderzo TV Italia
Ph. +39.0422.85.38.38
Fax +39.0422.85.35.85
info@niceforyou.com

Nice in Italy

Nice Padova

Padova Italia
Ph. +39.049.87.01.05.1
Fax +39.049.87.07.63.8
infoPd@niceforyou.com

Nice Roma

Roma Italia
Ph. +39.06.72.67.17.61
Fax +39.06.72.67.55.20
inforoma@niceforyou.com

Nice Worldwide

Nice France

Buchelay France
Ph. +33.(0)1.30.33.95.95
Fax +33.(0)1.30.33.95.96
info@fr.niceforyou.com

Nice France Sud

Aubagne France
Ph. +33.(0)4.42.62.42.52
Fax. +33.(0)4.42.62.42.50
infomarseille@fr.niceforyou.com

Nice France Rhône Alpes

Decines Charpieu France
Ph. +33.(0)4.78.26.56.53
Fax +33.(0)4.78.26.57.53
infoLyon@fr.niceforyou.com

Nice Belgium

Leuven (Heverlee) Belgium
Ph. +32.(0)16.38.69.00
Fax +32.(0)16.38.69.01
info@be.niceforyou.com

Nice Deutschland

Gelnhausen Deutschland
Ph. +49.(0)6051.91.520
Fax +49.(0)6051.91.52.119
info@de.niceforyou.com

Nice España Madrid

Mostoles Madrid España
Ph. +34.(0)9.16.16.33.00
Fax +34.(0)9.16.16.30.10
info@es.niceforyou.com

Nice España Barcelona

Sant Quirze del Valles
Barcelona España
Ph. +34.(0)9.37.84.77.75
Fax +34.(0)9.37.84.77.72
info@es.niceforyou.com

Nice Australia

Wetherill Park Australia
Ph. +61.(0)2.96.04.25.70
Fax +61.(0)2.96.04.25.73
info@au.niceforyou.com

Nice China

Shanghai P. R. China
Ph. +86.21.575.701.46
Fax +86.21.575.701.44
info@niceforyou.com.cn

Nice USA

San Antonio Texas USA
info@us.niceforyou.com

Nice Russia

Odintsovo Moscow Region Russia
Ph. +7.495.739.97.02
Fax +7.495.739.97.02
info@ru.niceforyou.com

Nice South Africa

Johannesburg South Africa
info@co.za.niceforyou.com

Nice Polska

Pruszków Polska
Ph. +48.(022).759.40.00
Fax +48.(022).759.40.22
info@pl.niceforyou.com

Nice Portugal

Mem Martins Portugal
Ph. +351.21.922.82.10
Fax +351.21.922.82.19
info@pt.niceforyou.com

Nice Romania

Cluj Napoca Romania
Ph./Fax +40.(0)264.453.127
info@ro.niceforyou.com

Nice Turkey

Kadikoy Istanbul Turkey
Ph. +90.216.456.34.97
Fax +90.216.455.78.29
info@tr.niceforyou.com

Nice UK

Sutton in Ashfield
United Kingdom
Ph. +44.16.23.55.80.86
Fax +44.16.23.55.05.49
info@uk.niceforyou.com